

J. P. J. Harb-

ELECTRICAL COMMUNICATION

ADVANCE DEVELOPMENT DEPARTMENT.

APRIL

No. 4

1935

VOL. 13

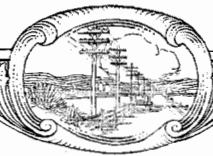

ELECTRICAL COMMUNICATION

A Journal of Progress in the
Telephone, Telegraph and Radio Art

H. T. KOHLHAAS, Editor

EDITORIAL BOARD

E. A. Brofos P. K. Condict G. Deakin E. M. Deloraine P. E. Erikson John W. Foard
James E. Fullam F. Gill Frank C. Page H. M. Pease G. E. Pingree

Published Quarterly by the

International Standard Electric Corporation

Head Offices

67 BROAD STREET, NEW YORK, N. Y., U. S. A.

European General Offices

CONNAUGHT HOUSE, ALDWYCH, LONDON, W. C. 2, ENGLAND

G. E. Pingree, President

S. G. Ordway, Secretary

Joseph A. Redegeld, Treasurer

Subscription, \$3.00 per year; single copies 75 cents

Volume XIII

APRIL, 1935

Number 4

CONTENTS

	PAGE
NEW A-C. MAINS OPERATED SPEECH INPUT EQUIPMENT AT LAUSANNE	279
<i>By Dipl. Ing. E. Metzler and R. W. Hardisty, M.A., B.Sc.</i>	
ANTI-SIDE TONE TELEPHONE SETS.....	290
<i>By L. C. Pocock, M. Sc., A.M.I.E.E.</i>	
AUTOMATIC RECEIVER FOR DISTRESS SIGNALS.....	301
<i>By O. Bracke and P. Giroud</i>	
THE 7-D ROTARY AUTOMATIC TELEPHONE SYSTEM.....	311
<i>By W. Hatton and J. Kruithof, e.i.</i>	
WIDE BAND TRANSMISSION OVER BALANCED CIRCUITS.....	348
<i>By A. B. Clark, Fellow A.I.E.E.</i>	
THE NEW STANDARD REPEATER EQUIPMENT.....	353
<i>By J. S. Lyall, B.Sc., A.M.I.E.E., A.C.G.I.</i>	
ESTERIFIED FIBROUS INSULATING MATERIALS.....	359
<i>By A. A. New, M.Sc.</i>	
RECENT TELECOMMUNICATION DEVELOPMENTS OF INTEREST.	380

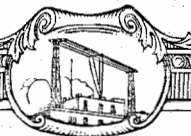

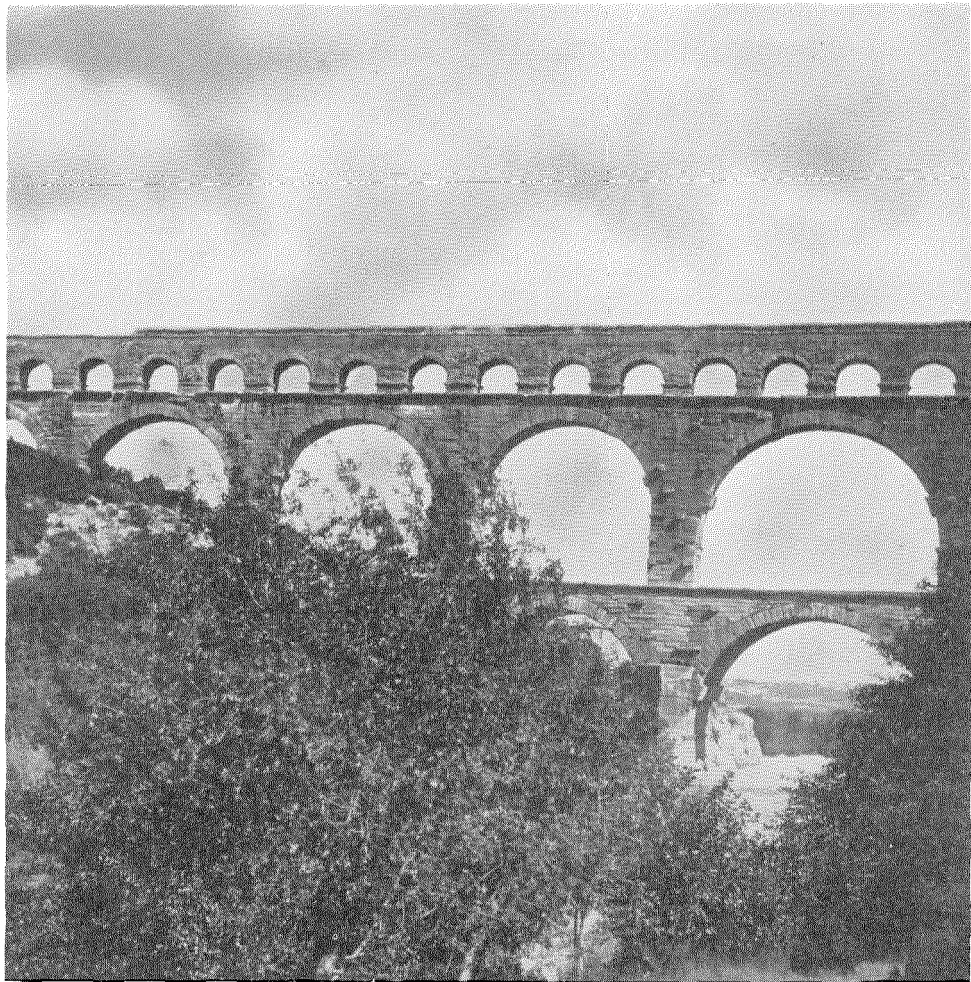

A PICTURESQUE COMMON CARRIER BUILT
BY THE ROMANS ABOUT 19 B.C.—“PONT
DU GARD” AQUEDUCT, NÎMES, FRANCE

New A-C. Mains Operated Speech Input Equipment at Lausanne

By Dipl. Ing. E. METZLER
Swiss Post and Telegraph Administration
and R. W. HARDISTY, M.A., B.Sc.
Bell Telephone Manufacturing Company

A new and up-to-date studio building has recently been inaugurated by the Société Romande de Radiophonie at Lausanne, Switzerland. This studio building, which caters for some of the programmes originated in French-speaking Switzerland, incorporates many new features and has been equipped with the latest type of all-mains speech input equipment. This article deals with the design of this equipment and its application to the various types of programme transmitted in modern radio broadcasting.

THE new studio building of the Société Romande de Radiophonie, which was opened for service in February, 1935 is situated close to the main Lausanne-Berne road at La Sallaz at a height of about 700 metres above the Lake of Geneva in a rapidly developing suburban area.

The Société Romande de Radiophonie has operated a broadcast service in Lausanne from the earliest days of broadcasting when the small telephone transmitter, then located at the Lausanne airport, was used and broadcasting had to be suspended when service messages to aircraft were transmitted.

In 1930 the new Swiss National Transmitter at Sottens was opened, and broadcasting in French-speaking Switzerland entered on a new phase of development.

Shortly after the opening of the Sottens station, the Bell Telephone Manufacturing Company was commissioned with the reequipment of the five existing studio centres in Switzerland: Berne, Basle, Lausanne, Geneva, and Zurich, as well as the installation of a new studio building at Lugano to serve the Italian-speaking region.

In 1933 the Société Romande de Radiophonie (S.R.R.) decided that the studio accommodation at Lausanne was inadequate for their needs and purchased a site at La Sallaz, where the new studio now stands.

The new building is constructed of cement-

faced brick, the walls of the studio which are also constructed of brick being insulated acoustically from the outer shell of the building.

There are seven studios and an artificial echo room. The largest studio is a concert hall and has been designed to accommodate the Suisse Romande Orchestra. It is 25 by 15 by 10 metres high and is equipped with a concert organ.

There are three medium sized studios for chamber music and radio plays; the two radio play studios being differently treated acoustically. Two talks studios, an effects studio, and the echo room complete the programme accommodation in the building. The remainder of the building provides for the administrative offices, a lounge for the orchestra, a music library, and the caretaker's living quarters.

The principal floor plans of the building are shown in Figs. 1a, 1b, and 1c, from which it will be seen that only two of the studios are visible from the Control Room. This has necessitated a very complete signalling system.

Overlooking the two radio play studios is the Dramatic Control Panel Room. This room contains an eight channel mixer which can be placed in the hands of the dramatic producer to enable him to fade his actors in and out as required during the play. On each side of the Dramatic Control Panel itself are the gramophone reproducer sets, used for effects during plays and for regular broadcasts of gramophone music. Stock market reports and sporting announcements are

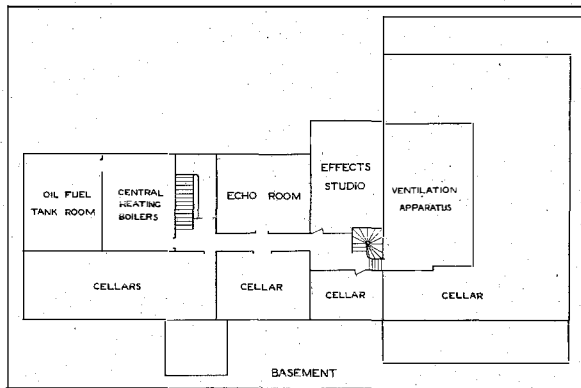

Figure 1a—Floor Plan.

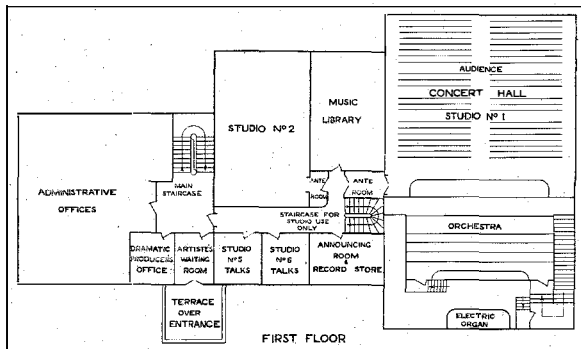

Figure 1b—Floor Plan.

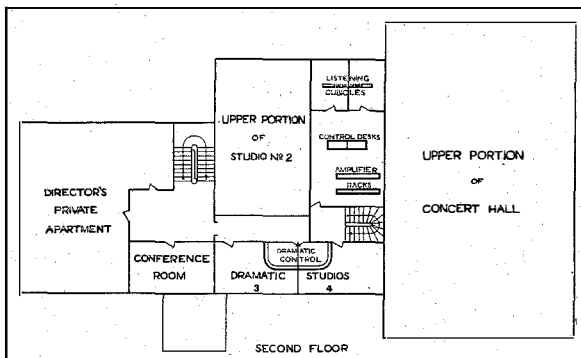

Figure 1c—Floor Plan.

made from this room. The Dramatic Control Room is therefore also used as an announcer's room.

In order to enable a correct modulation control to be effected during large orchestral broadcasts, two special control rooms have been provided. These have been equipped with a gain control potentiometer and a wide range loudspeaker combination so that the studio musical director

or other official can himself control the modulation of the programme during the performance of the concert, while listening to the programme under conditions as nearly ideal as possible.

New Standard Speech Input Equipment Amplifier Design

The amplifiers which make up the New Standard Speech Input Equipment as installed at Lausanne have been designed for either mains or battery operation, and have the advantage of low consumption obtained by the use of quarter ampere repeater type valves throughout. They do not, therefore, suffer from the disadvantage of heavy filament battery consumption when operated from batteries, and their background noise when supplied from a-c. mains is as low as that obtainable by the use of special type equipotential valves, the actual noise level due to a-c. components in the filament current being below the level of the noise due to the various sources of noise in the valves themselves.

The total gain between microphone and line is divided among four amplifiers. A microphone amplifier with a gain of 12 db. used between moving coil microphones and studio mixers and an "A" amplifier with a maximum gain of 70 db. constitute the "low level" amplifiers. In general, one microphone amplifier per microphone and one "A" amplifier per studio are employed.

The "high level" amplifiers constituting the remainder of the chain are a "B" amplifier and a "C" amplifier with a combined gain of 45 db. One "B" amplifier per programme channel and one "C" amplifier per output line are employed where more than one broadcaster is supplied with the same programme. In the installation now being described, output branching is not performed at the studio building, and a "B" amplifier with a single output is used. This amplifier has a gain of 35 db.

Figs. 2a, 2b, and 2c show the circuit arrangements of the microphone and "A" and "B" amplifiers, respectively.

In every type of amplifier the filament circuits of all valves are built out, where necessary, to 4 volts and are brought to separate terminals on the panel. Every amplifier can therefore be operated from 6 volt, 12 volt, or 24 volt batteries

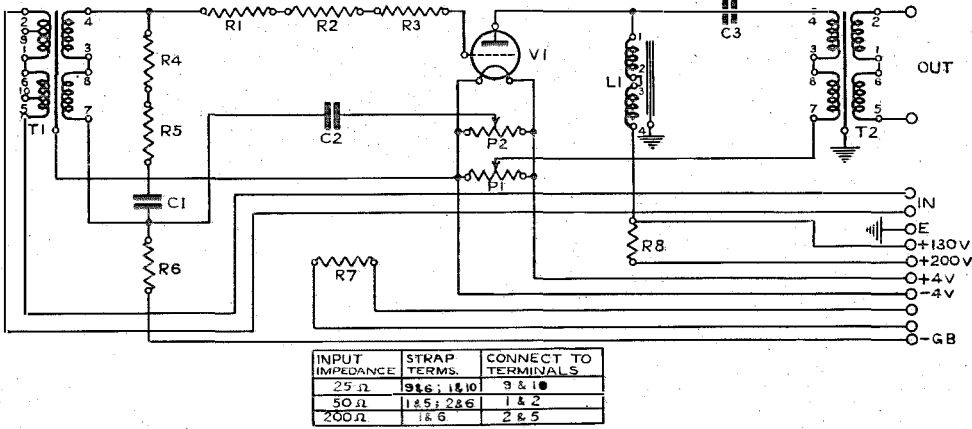

Figure 2a—Circuit Schematic of Microphone Amplifier.

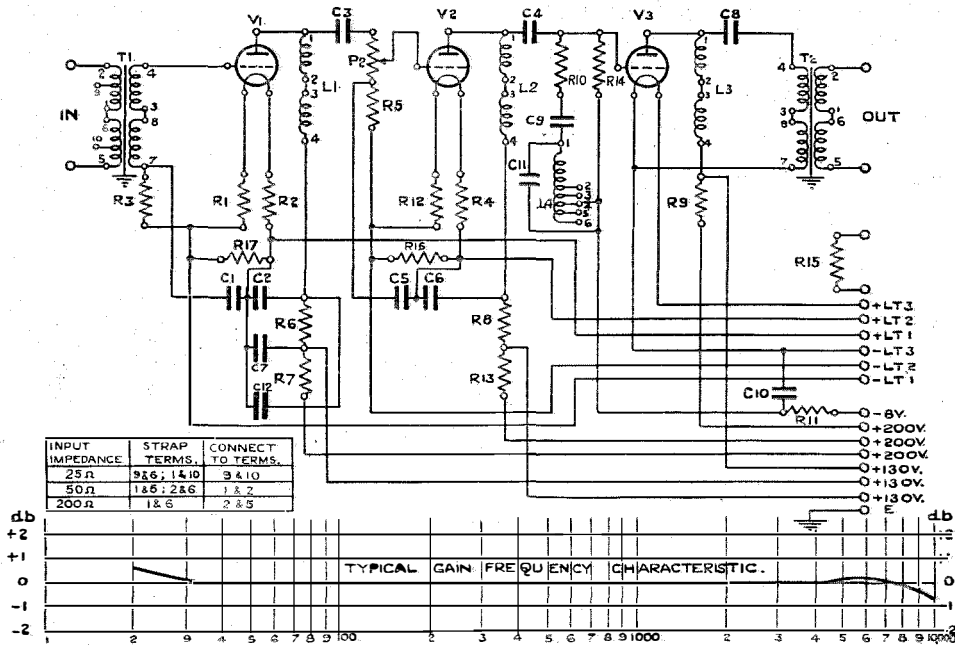

Figure 2b—Circuit Schematic of "A" Amplifier.

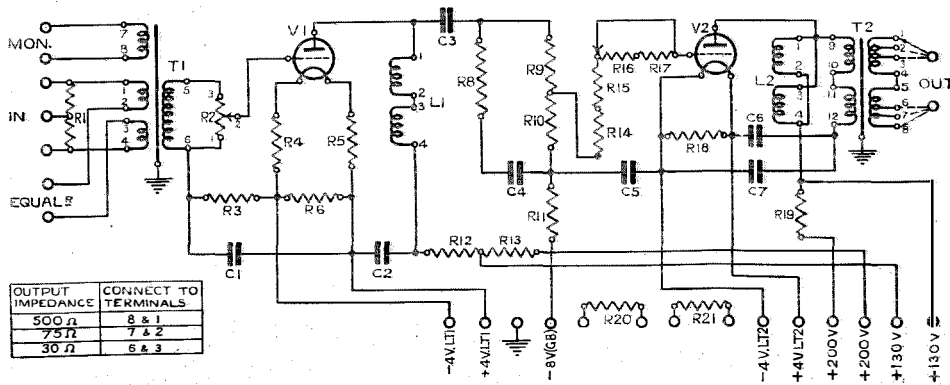
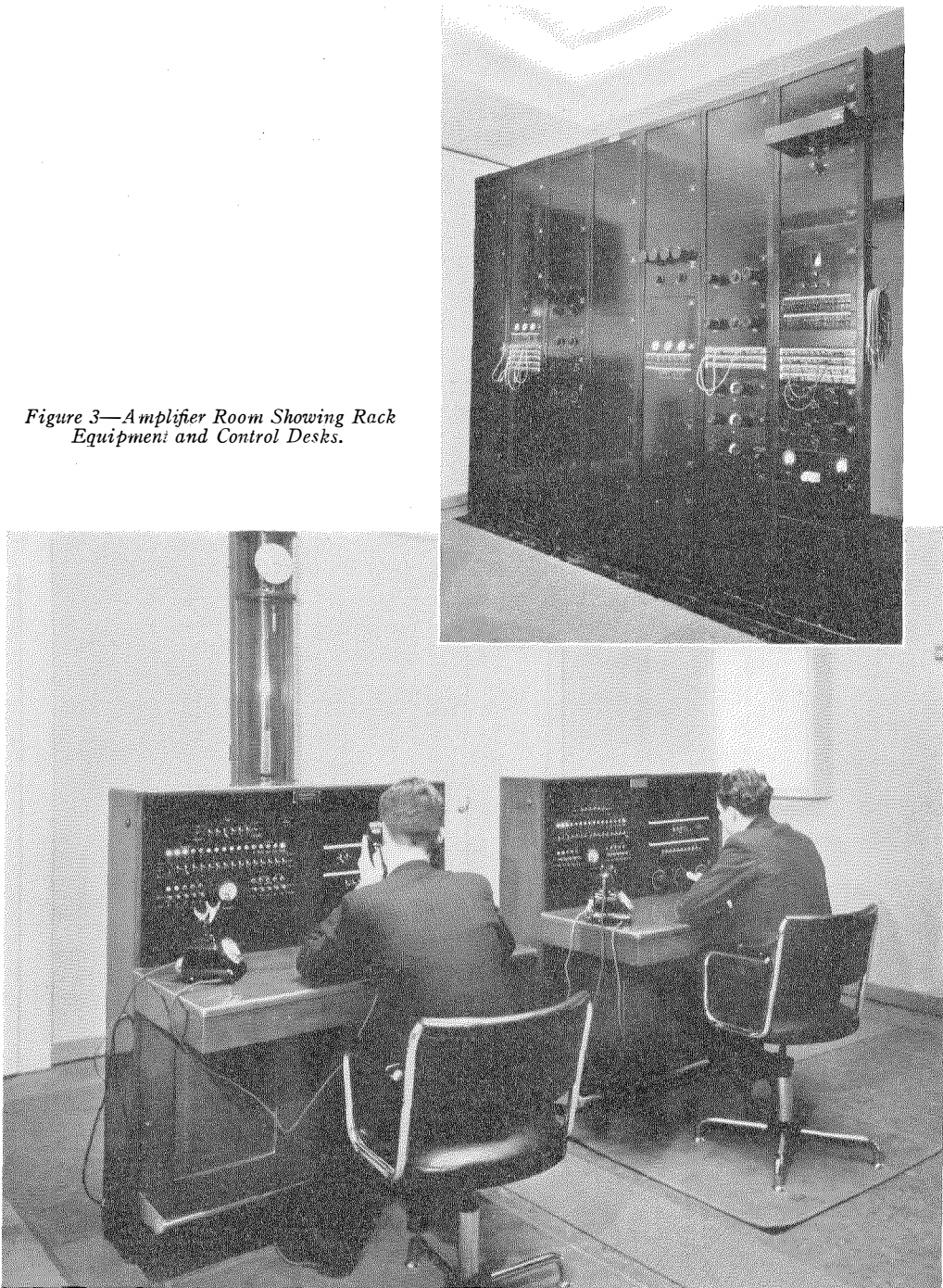

Figure 2c—Circuit Schematic of "B" Amplifier.

Figure 3—Amplifier Room Showing Rack Equipment and Control Desks.



by suitably connecting the filament circuits. With 6 volt and 24 volt supplies there is sufficient margin of voltage to include filament decoupling chokes as a safeguard against crosstalk through the battery; with 12 volt and 24 volt supplies all grid bias potentials can be taken from resistances in the filament circuits.

Plate circuits are arranged for 130 volt or 200 volt supplies and the equipment is therefore generally capable of being adapted for operation from batteries which may already be in service.

Metering arrangements for plate currents have been eliminated from the panels and are arranged at a central point on the equipment. Two such central metering points will be seen in the view (Fig. 3) of the Lausanne amplifier racks. This arrangement makes it possible to mount the amplifiers anywhere on a standard repeater type rack without the necessity of taking into consideration the question of accessibility, except for occasional valve replacements.

Only the high level ("B", "C", and monitoring) amplifiers have any apparatus projecting in front of the mounting plate; all valves in the low level (microphone and "A") amplifiers being mounted under the can covers.

The elimination of noise due to mechanical and acoustic shock on the valves has received special attention. Every amplifier, both high and low level, is equipped with spring mounted valve sockets which, in the case of the low level amplifiers, are themselves mounted on a sprung platform weighted with the input and output transformers. In the microphone amplifier, the valve is mounted under a felt-lined metal cover and a similar precaution is taken for the first two valves of the "A" amplifier. Fig. 4 shows a bay of "A" amplifiers with covers removed. On the high level amplifiers metal shields are used over the projecting valves.

All amplifiers are equipped with interstage equalisers so that the distortion at each end of the frequency range due to the transformers may be compensated. By this means the overall characteristics of a system comprising microphone amplifier, "A" amplifier, "B" amplifier (and "C" amplifier when used for output branching) can be adjusted to lie within 2 db. in the range of 30—10,000 cycles. Special precautions in the amplifiers have been necessary

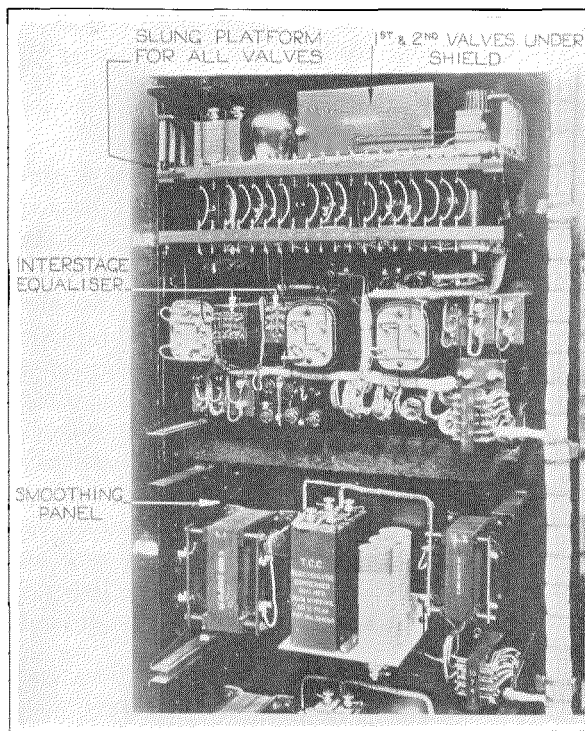

Figure 4—"A" Amplifier Bay (Rear View—Covers Removed).

to ensure stability, since the overall gain from microphone to line exceeds 100 db.

Single-output "B" amplifiers and "C" amplifiers are supplied with multi-ratio output transformers so that the output impedance can be adjusted to be considerably less than that of the line it feeds, and the amplifier thus sends a constant voltage to line independent of the impedance variations of the latter.

Mixer Design

Throughout the system only one type of mixer potentiometer is used. This potentiometer provides twenty-two steps and a cut-off position and can be built up to two, three, and four-channel units, terminating and building-out resistances being provided so that all mixers have input and output impedances of 200 ohms. Special arrangements have been made to reduce crosstalk to a minimum. Each potentiometer is furnished with an auxiliary cam-operated contact which opens only in the "cut-off" position and which is used to operate warning light relays, etc. The attenuation per step increases as

the total attenuation increases and a smooth fade-out without sudden cut-off is therefore obtainable.

Reproducer Sets

The gramophone equipment supplied is designed for 78 r.p.m. and $33\frac{1}{3}$ r.p.m. playing speeds. The pick-up arm is equipped with an indicating scale so that the pick-up may be lowered at any predetermined point on the record. The gramophone sets are built on a unit basis as "playing units", each consisting of a pick-up, motor, turntable, and fader mounted on a steel plate. The fader is of the same type as that used on the mixer panels and the auxiliary contacts are used to operate a device for raising and lowering the pick-up. This feature is especially useful when using effects records in radio drama, since the pick-up may be lowered on to a groove in the record in which the desired noises occur.

Signalling System

In a modern studio building where many, if not all, of the studios are out of sight of the Control Room, a complete and unambiguous signalling system is essential.

The signalling system which has been adopted after prolonged experience on Standard Speech Input Equipments provides a "Ready" signal between the studio and the Control Room, and a "Start" signal between the Control Room and the studio. In addition, a red warning light in any studio lights when the microphones in that studio are connected through to the amplifiers. This red lamp is entirely automatic in operation and is independent of the "Start" signal.

The "Ready" and "Start" signal system consists of a green lamp in the studio and a corresponding switchboard lamp in the Control Room. These two lamps light simultaneously and can be lit or extinguished either from the studio or from the Control Room. The lighting of the lamps by the studio leader, or conductor of the orchestra usually constitutes the "Ready" signal and the extinction of the lamps by the control engineer constitutes the "Start" signal.

In addition to the above, a simple system of blue lights is used from the Dramatic Control Room as cues for the actors to speak their lines during the performance of the radio plays.

These lamps are operated by locking keys on the Dramatic Control Panel and can be extinguished only by the producer.

Level Indicators

The Lausanne installation is one of the first to use the newly developed Standard Programme Meter. This device is a rectifying valve voltmeter which is arranged to have an approximately logarithmic characteristic so that level is indicated directly in decibels. The milliammeter included in the plate circuit is specially calibrated from a level of -35 db. to a level of +5 db. referred to a zero level of 4 volts. A single frequency calibrating oscillator is provided to enable the zero indication at 4 volts to be checked and adjusted periodically.

The advantage which the new panel offers over other types of level indicators can best be appreciated after actual control of a musical broadcast. The special logarithmic scale is obtained without the use of multi-electrode valves or of specially constructed meters, two reactance coupled valves only being employed.

The calibrating oscillator used with the programme meter can also be used to check the attenuation of an outside broadcast circuit. The circuits normally used for outside broadcasts vary in length from 1 or 2 to 20 or 30 miles, and Standard Electric outside broadcast amplifiers are used at the pick-up point. These amplifiers have a rectifier meter connected across the output; and, by transmitting a known level from the studio with the oscillator, the attenuation of the circuit can be measured roughly by means of the meter on the outside broadcast amplifier. The operator at the remote pick-up point can then adjust his amplifier gain so as to feed the correct level to the studios.

Mains Operation

From the outset it was decided that the entire equipment should be operated from the 220 volt, 50 cycle a-c. mains with the exception of the signalling system and the intercommunicating telephone system, which are operated from a 24 volt battery.

Two schemes suggested themselves. In the first scheme each amplifier is associated with a separate rectifier and smoothing panel for both high and low tension supply; while in the second

scheme, floating batteries used in conjunction with large central rectifiers and filters are controlled by means of voltmeter relays, so that at all times battery power is available in case of mains failure, while the batteries cannot be overcharged due to the action of the voltmeter relays.

After careful consideration, the Swiss Administration selected the first scheme. Each amplifier panel is, therefore, associated with a rectifier panel located on a separate rack assembly so as to minimise induced fields. The rectifier panels incorporate two stages of filtration and these are found to attenuate the residual hum sufficiently to permit satisfactory operation of the high level amplifiers. Microphone amplifiers and "A" amplifiers are, however, each equipped with an additional smoothing panel incorporating a third stage of filtration. These smoothing panels are located on the amplifier bays close to the amplifiers with which they are associated in order to avoid induction from the input of the

filtering system to its output, the attenuation in the filters being of the order of 110 db. for the low tension, and 130 db. for the high tension.

Two transformers are provided, stepping the 220 volt mains down to 35 and 125 volts respectively for low and high tension supplies, and each rectifier panel takes its supply from a separate low tension and a separate high tension winding.

The background noise on the system, when supplied from the mains, is reduced to the level of the valve noise.

Circuit Arrangements in Lausanne Speech Input Equipment

Microphones

Standard moving coil microphones have been used for all general pick-up work, condenser microphones being retained for orchestral broadcasts. Circuit arrangements have been provided to take care of the widely different output levels of the two types. In addition, it was necessary to

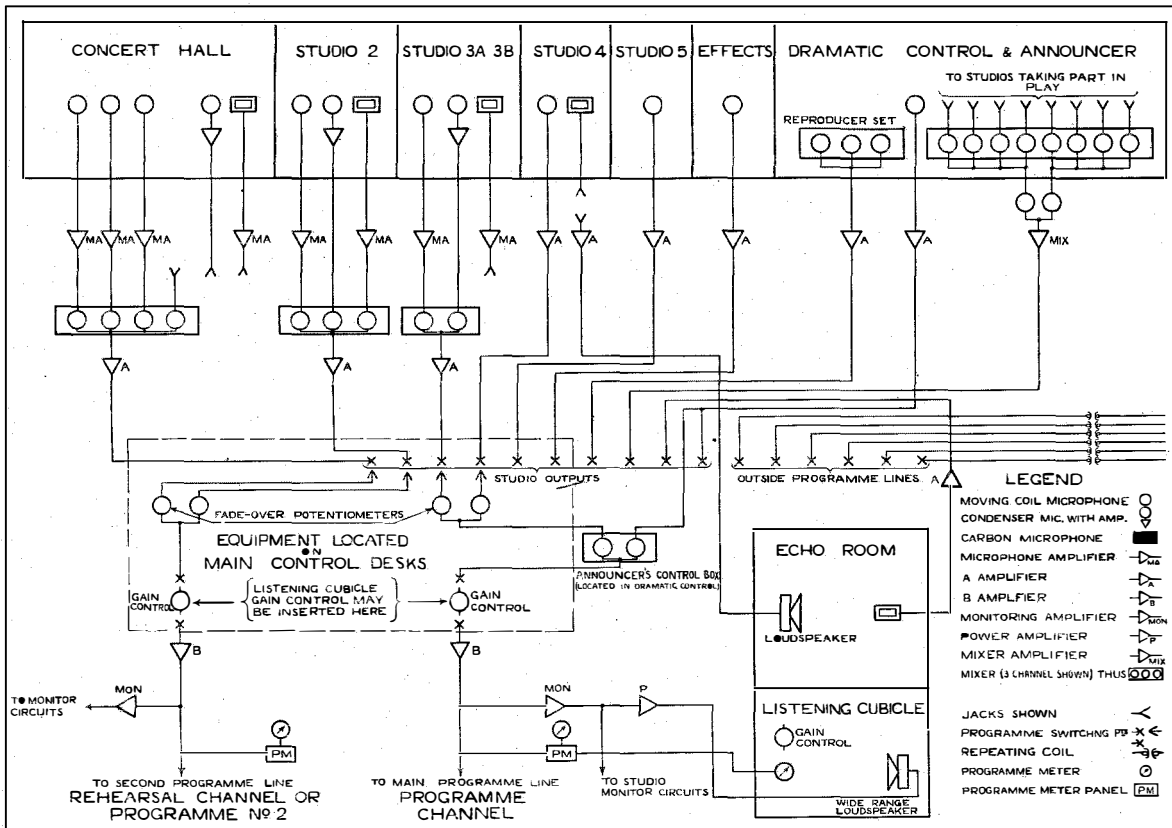

Figure 5—Overall Circuit Layout.

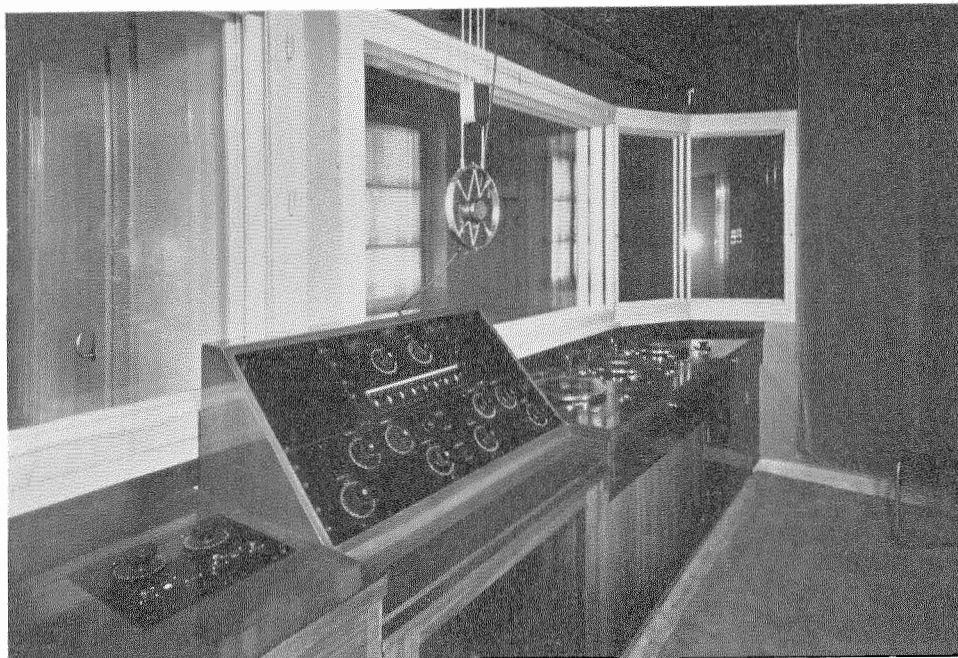

Figure 6—Dramatic Control Panel.

cater for a certain number of carbon microphones for use in the effects studio and in the echo room where stringent quality requirements do not exist.

The solution arrived at involves the provision of the microphone amplifiers described above for all moving coil and carbon type microphones. These amplifiers are rack-mounted and are located in the main amplifier room where they can be under constant supervision and so have an advantage over the condenser microphone amplifiers which must be located in the studios. The amplifiers for the carbon microphones supply polarising current derived from the filament circuit rectifiers to the microphones themselves. Fig. 5 shows the general system layout from which it will be seen that the three principal studios are each equipped with several microphones and the outputs of their associated microphone amplifiers are brought to four, three and two-channel mixers. The object of these mixers is to obtain a realistic reproduction of all the instruments in an orchestra, and for this reason the placing of the microphones and the setting of the mixers demand a great

deal of patient experiment on the part of the programme staff prior to the broadcast. When the final settings have been decided upon they are recorded, and the conditions obtained can then be repeated during the broadcast performance.

With a view to the employment of a Dramatic Control Panel and for other reasons, high level fading and switching was decided upon, and every programme source, studio, gramophone, etc. is equipped with an independent "A" amplifier so that at the switches on the engineer's control desk the level of the studio programme is approximately equal to that from the outside broadcast lines. This condition can be realised by the individual adjustment of gain provided in each "A" amplifier.

When used for the production of a radio play, any studio can be patched to any input channel of the Dramatic Control Panel, and thenceforth it is completely under the control of the producer up to the time that the patching cords are removed and the studios are again connected to the regular control and switching desks for normal programme use. While connected to the

Dramatic Control Panel, the red warning lamps in the studio are automatically operated when the producer fades out the studio. The layout of the Dramatic Control Panel, a view of which is shown in Fig. 6, has been carefully arranged for operation by essentially non-technical personnel.

Another interesting feature of the installation is the provision of artificial echo. This device was at one time used in an endeavour to simulate concert hall acoustics when using a small heavily damped studio, but its use is now almost entirely confined to the provision of special effects in radio plays.

Artificial echo is produced by splitting off a small portion of the microphone output and reproducing the sound by means of a loudspeaker in a reverberant room. Here the reverberant sound is picked up by another microphone and the output of this microphone is mixed with the output from the studio. A common way of achieving this result is to split off the output to the echo room at the output of the studio "A" amplifier at a level of about -10 to -20 db. as shown in Fig. 7. The arrows indicate the direction in which the amplifiers operate. An additional amplifier (A.S.A.) is often added, as

shown, as a precaution against singing round the path a, b, c, d, e, and f.

In the Lausanne studios, however, the echo room loudspeaker is fed from a separate microphone and the resultant reverberant sound may be mixed either at low level on the studio mixer or at high level on the main control positions or on the Dramatic Control Panel. With this arrangement there is no possible singing path and an anti-singing amplifier is not required.

The programme control equipment is duplicated so that it is possible for rehearsals before the microphone to be conducted at any time while broadcasting is in progress. Two control desks are provided in the Amplifier Room, each being associated with a "B" or line amplifier, and each having access through its switching panel to every studio or programme source inside the building or to any outside broadcast line. In case of a breakdown of one programme channel it is possible immediately to pick up the studios in use on the other channel and to continue the broadcast with a delay of only 10 to 20 seconds. Crosstalk between the two programme channels received very careful attention and the figure measured on the installation was in accordance with C.C.I. requirements for crosstalk between

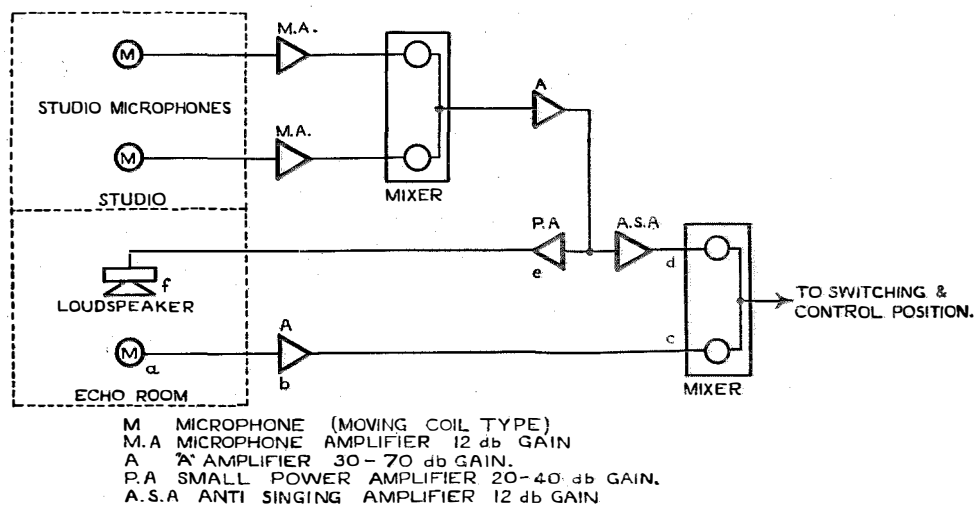

Figure 7—Echo Circuit Schematic.

repeaters (10 nepers = 87 db.). The "B" or line amplifiers are designed for one output only; further output branching is performed at the Lausanne Repeater Station to which the output of the studio amplifiers passes. Here there are four branching amplifiers connected with the broadcast repeater which feed lines to Sottens Broadcaster, Berne, Geneva (local broadcaster), and Martigny. The fourth amplifier (Martigny) also feeds the local teleprogramme amplifier which provides the programme to subscribers' loudspeakers on the Lausanne automatic exchange.

The above reference to teleprogramme services in Switzerland may call for some further comment. The service was instituted in the larger towns in 1931 and provides telephone subscribers who rent an amplifier-loudspeaker equipment with reliable high quality reproduction from one of the three Swiss programmes (German, French, or Italian). This service is provided entirely from the toll cable system and is therefore unaffected by weather conditions or by other sources of interference. It is now available in nearly every important town in Switzerland and is being extended as rapidly as the high quality toll circuits themselves can be

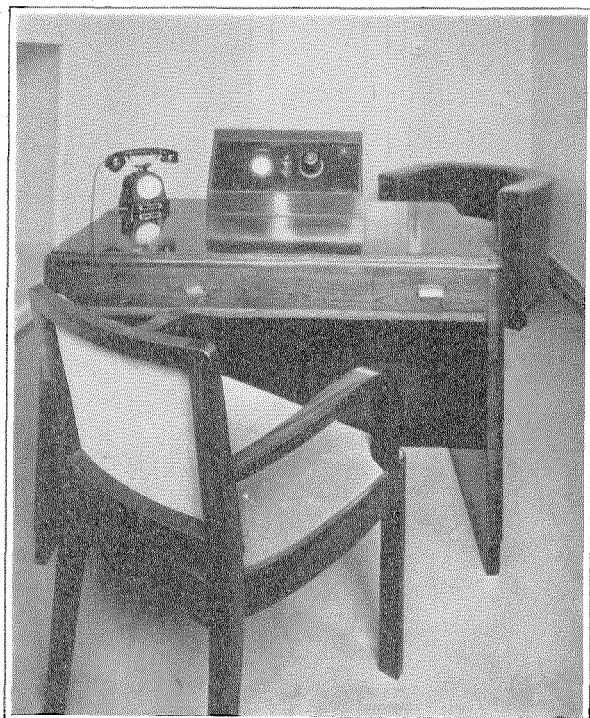

Figure 8—View Inside Listening Cubicle.

extended to the towns concerned. The service is made use of by the studio for quality checking and for verification of the circuits when a change-over to another studio is made. Such a change-over occurs several times daily when the Geneva studio takes up the French programme or when the news bulletin is read from Berne. In certain cases relay operation has been arranged so that the reversal of the repeaters may be effected from the studio building itself, but in other cases where manual operation is involved it is of interest to check on the teleprogramme service whether the switch-over has been correctly performed. This can be easily done because the teleprogramme service is branched across the output of the Lausanne Repeater Station and, unless the repeater is switched over to receive the transmission from the studio continuing the programme, no output from the teleprogramme service will be obtainable. A check by the radio receiver ensures that the programme reaches the broadcasting station. It is thus possible to check the programme at each stage of its transmission between the studio and the broadcasting station.

Monitoring, therefore, can be effected on the outgoing line from the studio building, at the output of Lausanne Repeater Station, and by a radio receiver at the output of the Sottens broadcaster. In the amplifier room, in the two listening cubicles, in the effects room, and in the Dramatic Control Room, all three of the above monitoring services are available on omnibus circuits. A fourth circuit connected with the output of the second programme channel is also available. Elsewhere in the building only the teleprogramme service is obtainable.

At all points loudspeakers of the teleprogramme type with self-contained amplifiers are installed. These can be branched across any of the four omnibus circuits and each circuit is adjusted so that a peak voltage of 3 volts is not exceeded. The loudspeaker amplifiers are all fitted with volume controls.

In places where microphones are installed, the monitoring service is cut off as soon as the associated "A" amplifier is connected at the Control Desk. The relay used to cut off the loudspeaker also cuts off the intercommunicating telephone and puts the "busy tone" on the line.

In the two listening cabins for the special

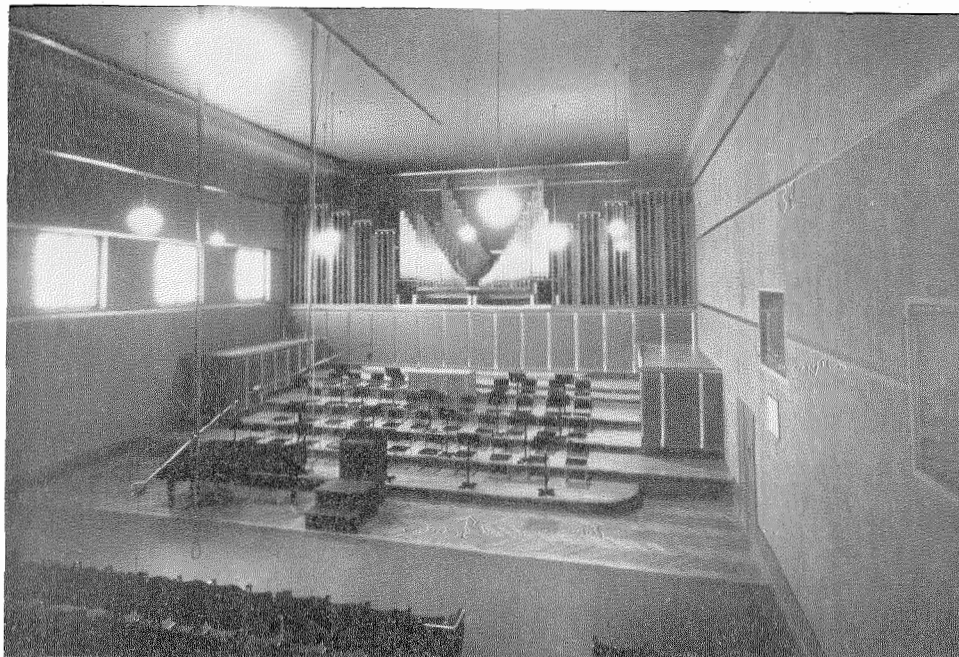

Figure 9—View Inside Concert Hall.

modulation control of a musical programme, wide range loudspeaker combinations are used. These are fed from a special power amplifier through dividing networks which split the frequency range into two bands which are then reproduced by the low-frequency and high-frequency units.

A special feature of the installation is an arrangement whereby the announcer may introduce his microphone on the programme at any time without the intervention of the control operator. This feature is useful, especially when a gramophone recital is being given; it then enables the entire programme to be handled by one man, since volume compression has already taken place when the original recording was made, and no further modulation control is therefore necessary when the record is broadcast. The large studio also incorporates an announcer's position so that announcements may be made from the studio itself.

Future Developments

In the main amplifier room, provision has been made for a second row of seven amplifier racks which should provide adequate space for apparatus required in connection with future extensions. With a view to future television developments, the building has been electrically screened by means of vertical copper wires inside the walls and a roof of copper sheeting.

The Société Romande de Radiophonie is now in possession of the largest and most up-to-date studio building in Switzerland. Great credit is due to the judgment and foresight of the Building Committee presided over by Mr. Baud, Chairman of the Swiss Broadcasting Co., and in particular to the Architect, M. Brugger, for the provision of many features which will prevent the building from becoming out of date due to future developments in radio broadcasting technique.

Anti-Side Tone Telephone Sets

By L. C. POCOCK, M.Sc., A.M.I.E.E.

It is shown in this article that the variation of side tone in an anti-side tone set is not under the control of the designer except in so far as the line impedance on which the set is to give optimum performance may be regarded as arbitrary, and to the extent that the different types of anti-side tone circuits give different characteristic variations of the no-side tone line impedance with frequency.

Appendices contain derivations of formulae which are intended for those interested in a complete study. The main article is written for reading without the appendices. Definitions of general symbols employed follow Appendix C.

A TELEPHONE set with the line impedance to which it is connected is a 4-pole network connecting the microphone and receiver. The line impedance is the variable element whose influence on side tone is to be considered. The microphone resistance also varies with the current through it, but such variations will not be considered.

An anti-side tone circuit differs from a side tone circuit in that the particular line impedance for which the side tone is zero at any frequency is a physically realisable impedance, that is, one having its real component positive.

In this paper, data has been given mainly for a single frequency, but the formulae and arguments applicable to one frequency are appropriate to any frequency, and the general conclusions are therefore valid. The single frequency chosen is 1100 p:s because it is approximately the frequency of maximum interference, and it is at or near this frequency that commercial receivers exhibit resonance when placed against the ear.

It should also be explicitly noted that the side tone properties of the network alone are considered. The actual side tone will evidently be affected in a simple manner by the efficiency of the microphone and receiver.

It will be convenient to express side tone and other quantities in terms of some standard—the most convenient is an ideal side tone circuit. Such a circuit may be very simply imagined as a series circuit in which the microphone and receiver are equal pure resistances, and the line is a resistance equal to twice either. It is easily seen that for such a set the side tone power will be $E_M^2/16M$, as stated in equation (B.1), Appendix B. This expression states the amount of side tone

power in an ideal set having a microphone resistance M . The side tone power measured in any actual set can be expressed in decibels below $E_M^2/16M$, the microphone e. m. f. E_M , being assumed the same.

In Appendix A it is shown that in any anti-side tone set the side tone current in the receiver is equal to the product of three quantities:

- (a) ΔL , the amount by which the line impedance differs from L , the impedance for which there is no side tone;
- (b) The current transmitted to the line $L + \Delta L$;
- (c) The current through the receiver when receiving with one volt acting in the line impedance L (no side tone line impedance).

Of these three factors it is evident that the second and third represent, respectively, the transmitting efficiency to line $L + \Delta L$, and the receiving efficiency from line L . Since it is obviously a requirement of design to keep these efficiencies high and to have the line impedance L assume a value characteristic of the impedance into which the set must work, neither of these two factors can be usefully varied to control side tone. Similarly, the first factor ΔL cannot be controlled except in so far as it can be kept small by choosing L as a mean of the impedances into which the set must work.

The relation given above may equally well be stated in terms of the side tone power and the transmitting and receiving power efficiencies relative to an ideal set. The formula is given in Appendix A, equation (A.13), in the form:

$$\eta_{ST} = \eta_M \eta_R \frac{(\Delta L)^2}{4 L_r (L + \Delta L)_r} \dots \dots \dots 1.$$

In this expression, η_{ST} , η_M , and η_R represent the side tone reduction, transmitting efficiency,

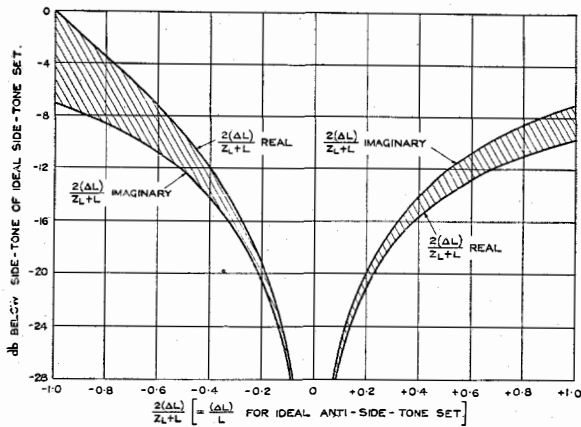

Figure 1—Side Tone of Anti-Side Tone Set.

$\Delta L/L$ is real and negative, the side tone is greater than for the same $|\Delta L|$ and any other argument.

Commercial Anti-Side Tone Set

The fact it is desired to bring out is that it is to be expected that in practice all anti-side tone sets will have the same shaped curve as Fig. 1 for the maximum and minimum side tone, such curves being displaced in ordinate values by an amount depending on the transmitting and receiving efficiency of the set.

In order to arrive at this conclusion, it is only necessary to compare equations (B.8) and (A.12). According to (B.8) the side tone power reduction of an ideal set is:

$$\left(\frac{\Delta L/L}{2+\Delta L/L}\right)^2 \dots\dots\dots 3.$$

According to (A.12), the side tone power reduction of a commercial set is:

$$\frac{16 MR_r}{Z_{ML}^2 Z_{LR}^2} \left(\frac{Z_L+L}{Z_L+L+\Delta L}\right)^2 (\Delta L)^2 \dots\dots 4.$$

The only part of this expression that depends upon ΔL is:

$$\left(\frac{(\Delta L)}{Z_L+L+\Delta L}\right)^2 \dots\dots\dots 5.$$

If the numerator and denominator of (5) are divided by $\left(\frac{Z_L+L}{2}\right)^2$ the result is:

$$\left(\frac{2 \Delta L/(Z_L+L)}{2+2 \Delta L/(Z_L+L)}\right)^2 \dots\dots\dots 6,$$

which has the same form as (3); therefore, if side tone values are plotted against $\Delta L/L$ for an ideal set, and against $2\Delta L/(Z_L+L)$ for a commercial set, the resulting curves must be identical in shape provided that $\Delta L/L$ and $2\Delta L/(Z_L+L)$ always have the same angle. It will be noted that $2\Delta L/(Z_L+L)$ becomes $\Delta L/L$ for an ideal set in which Z_L is equal to L .

Maximum and Minimum Side Tone

The next object of enquiry is the determination of the actual line impedances which should be used in order that the side tone may be a maximum or minimum for a given value of $|\Delta L|$;

and receiving efficiency, respectively, for defined conditions and all related to an ideal (side tone) set.

This formula shows very clearly that the side tone in any set depends solely upon the transmitting and receiving efficiency, together with the line impedances for which the set is designed, and the line impedance with which it is used.

Numerical illustrations of equation 1 are given in Table VI.

Ideal Anti-Side Tone Set

The variation of side tone with line impedance will now be considered, and for this purpose it is convenient to study first an ideal anti-side tone set.

In Appendix B (equation B.8) it is shown that an ideal anti-side tone set will have side tone power equal to

$$\left(\frac{\Delta L/L}{2+\Delta L/L}\right)^2 \times \left\{ \text{Side tone power of ideal side tone set} \right\} \dots\dots 2.$$

It should be noted that in an ideal anti-side tone set $Z_L=L$ =pure resistance.

Taking $\Delta L/L$ as a real quantity, a curve can be drawn of side tone reduction in decibels plotted against the value of $\Delta L/L$ (Fig. 1).

Similar curves can be drawn for complex values of ΔL and these will fill the shaded part of the diagram (Fig. 1).

It is seen that when $\Delta L/L$ is real (argument zero) and positive, the side tone is less than for the same $|\Delta L|$ with any other argument; when

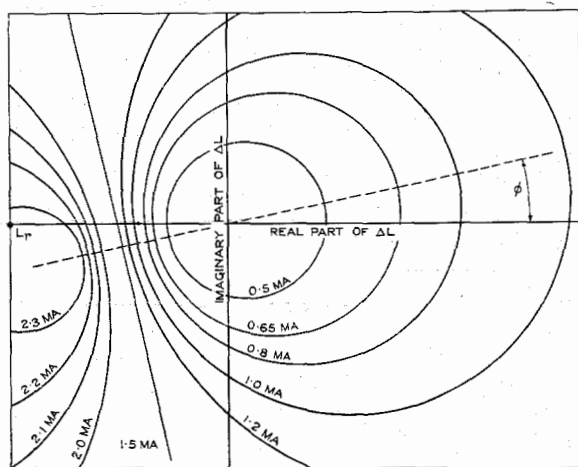

Figure 2—Constant Side Tone Current Loci.

or, in other words, the determination of ϕ' in $L + |\Delta L| / \phi'$ so that the side tone is a maximum or a minimum.

Appendix C gives the necessary formulae for drawing the well-known circular loci of equal side tone currents for any set (Fig. 2). In this manner of representation, line impedances are plotted in the complex plane, and impedance plots for which the side tone current is the same are joined to form equal side tone current loci. These loci are circles, and expression (C.3) enables the conclusion to be drawn that the centres of all the circular loci lie on a straight line inclined to the real axis at an angle ϕ , which is the angle of the impedance $(Z_L + L)$. The impedance L , for which the side tone is zero, also lies on this line, and corresponds to a circle of zero radius.

As a matter of convenience, the formulae in Appendix C have been adjusted to make the origin at L , so that the impedances plotted represent ΔL . A typical example is shown in Fig. 2.

It is evident that since the circles do not intersect and their centres are co-linear, the line through the centres will represent the direction in which the line impedance must change in order that the side tone may have the greatest and least value for a given value of $|\Delta L|$. Thus the required angle ϕ' is the angle ϕ defined by the angle of $Z_L + L$. Referring to (6), it will be noticed that when ΔL and $Z_L + L$ have the same angle, (6) assumes a real value corresponding with the curve in Fig. 1 for $\Delta L/L$ real.

Numerical examples are given in Tables I to V showing the observed side tone in commercial sets for values of ΔL chosen in the manner that has been described. For comparison, the side tone of an ideal anti-side tone set is shown for values of $\Delta L/L$ equal to $2 \Delta L / (Z_L + L)$ in the commercial set. It is seen that for each set the side tone is lower by an almost constant amount than the ideal set side tone, except in extreme cases where a slight variation results from the exaggerated effect of slight errors and instabilities of the no-side tone line impedance.

Although the relation between the side tone of a commercial set and an ideal anti-side tone set has been discussed only for special maximum and minimum characteristics, the side tone for any other direction of variation of ΔL is determined by the maximum and minimum characteristics and the properties of a circle: this is equally true for the ideal and the commercial anti-side tone set, and the side tone in each case is rigorously expressed by (3) and (4) respectively. The complete system of circles for a commercial set differs from the system of circles for an ideal set by a scale constant applied to the

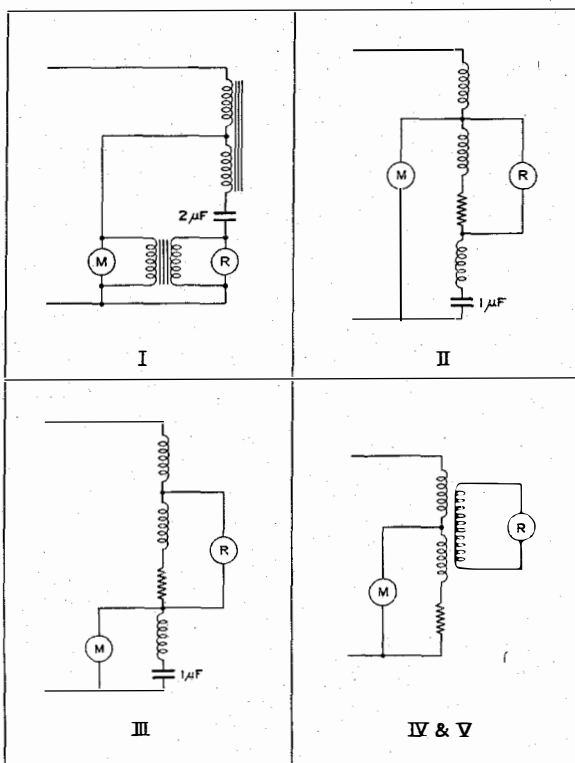

Figure 3—Schematic Circuits of the Telephone Sets Tested.

numerical value of i attached to each circle, and a rotation of the line of symmetry through the angle ϕ . The side tone power for the commercial set with any line impedance must therefore be the same constant fraction of the side tone power of the ideal set for some associated line impedance. Specifically, the side tone in the ideal set (L real) when the line unbalance is

determined by $\frac{|\Delta L|/\theta}{L}$ will bear a constant ratio to the side tone in a commercial set for which the line unbalance is determined by $\frac{2|\Delta L|/\theta + \phi}{Z_L + L}$.

Control of Side Tone by Design

It has been shown that at any frequency the side tone in any anti-side tone set varies with the line impedance in an invariable manner which is determined solely by the behaviour of the ideal anti-side tone set, and is not therefore under the control of the designer. It has also been shown that the constant difference between the side tone of a commercial set and an ideal anti-side tone set depends upon the internal efficiency of the set considered.

The actual line impedance on which a set is intended to work with maximum efficiency should be the conjugate of Z_L and, therefore,

TABLE I
SET NO. 1

$Z_L = 335 + j 372$

$L = 830 - j 1072$

ΔL	$L + \Delta L$	$\frac{2\Delta L}{Z_L + L}$	Side Tone Power Below Ideal Side Tone Set		Difference
			Observed	Ideal A.S.T. Set	
100 - j 59	930 - j 1132	.17	db.	db.	db.
200 - j 119	1030 - j 1191	.34	-31.1	-22	9.1
300 - j 178	1170 - j 1240	.51	-25.9	-16.7	9.2
400 - j 238	1230 - j 1310	.69	-23.7	-13.8	9.9
500 - j 297	1330 - j 1370	.86	-21.6	-11.8	9.8
-100 + j 59	730 - j 1012	-.17	-20.3	-10.4	9.9
-200 + j 119	630 - j 953	-.34	-29.8	-20.6	9.2
-300 + j 178	530 - j 894	-.51	-24.5	-13.8	10.7
-400 + j 238	430 - j 834	-.69	-19.9	-9.3	10.6
-500 + j 297	330 - j 775	-.86	-16.2	-5.6	10.6
	Open Circuit	-	-13.1	-2.5	10.6
			-10.1		
			AVERAGE..		9.9

TABLE II
SET NO. 2

$Z_L = 550 + j 246$

$L = 560 - j 400$

ΔL	$L + \Delta L$	$\frac{2\Delta L}{Z_L + L}$	Side Tone Power Below Ideal Side Tone Set		Difference
			Observed	Ideal A.S.T. Set	
100 - j 14	660 - j 414	.18	db.	db.	db.
200 - j 28	762 - j 428	.36	-28.3	-21.6	6.7
300 - j 42	862 - j 442	.54	-22.3	-16.4	5.9
500 - j 70	1062 - j 470	.90	-19.3	-13.6	5.7
-100 + j 14	462 - j 368	-.18	-16.0	-10.2	5.8
-200 + j 28	362 - j 372	-.36	-26.2	-20.0	6.2
-300 + j 42	262 - j 358	-.54	-19.6	-13.2	6.4
	Open Circuit	-	-14.8	-8.7	6.1
			-5.8		
			AVERAGE..		6.1

when a set is designed for known existing line impedances, Z_L cannot be considered as arbitrary. The value of the no-side tone line impedance is also a quantity determined by existing lines and cannot be arbitrarily chosen: theoretically, L should be real and equal to Z_L ; generally, in well designed sets, Z_L and L are approximately conjugate.

Obviously nothing is left to the designer but to choose the particular type of circuit for which L happens to be a function of frequency most nearly approximating to the line impedance-

frequency characteristic for which it is desired to reduce side tone to the utmost; the extent of the control obtainable by this means is so limited that in general other more important factors intervene.

Experimental

A number of the types of telephone sets extensively used in various countries were selected for experimental study. The sets were all designed with different circuits, as may be seen from the schematics in Fig. 3.

TABLE III
SET No. 3
 $Z_L = 900 + j 680$ $L = 928 - j 150$

ΔL	$L + \Delta L$	$\frac{2\Delta L}{Z_L + L}$	Side Tone Power Below Ideal Side Tone Set		Difference
			Observed	Ideal A.S.T. Set	
100 + j 28	1028 - j 130	.11	db. -28.9	db. -25.7	3.2
200 + j 57	1128 - j 100	.22	-22.4	-20.2	2.2
300 + j 85	1228 - j 73	.33	-19.4	-17.1	2.3
400 + j 114	1328 - j 44	.44	-17.4	-15.0	2.4
-100 - j 28	828 - j 186	-.11	-27.1	-25.1	2.0
-200 - j 57	728 - j 215	-.22	-21.1	-18.2	2.9
-300 - j 85	628 - j 246	-.33	-16.8	-14.2	2.6
-400 - j 114	528 - j 272	-.44	-13.8	-11.1	2.7
	Open Circuit	-	- 7.7	0	
AVERAGE					2.5

TABLE IV
SET No. 4
 $Z_L = 400 + j 245$ $L = 536$

ΔL	$L + \Delta L$	$\frac{2\Delta L}{Z_L + L}$	Side Tone Power Below Ideal Side Tone Set		Difference
			Observed	Ideal	
100	636	.21	db. -25.6	db. -20.4	5.2
200	736	.41	-20.1	-15.4	4.7
300	836	.62	-17.4	-12.6	4.8
400	936	.82	-15.4	-10.7	4.7
500	1036	1.02	-14.1	- 9.5	4.6
-100 - j 26	436 - j 26	-.22	-23.1	-18.3	4.8
-200 - j 52	336 - j 52	-.43	-16.1	-11.2	4.9
-300 - j 78	236 - j 78	-.65	-11.4	- 6.3	5.1
-400 - j 104	136 - j 104	-.86	- 7.1	- 2.5	4.6
	Open Circuit	-	- 5.6	-	
AVERAGE					4.8

Note: Small positive reactances in $L + \Delta L$ omitted for experimental convenience; the error introduced is negligible.

For the purpose of the study it was necessary to measure:

- Z_L The impedance of the set at its line terminals.
- L The line impedance giving no side tone.
- R The receiver impedance.
- V_{ST} The side tone voltage across the receiver with various line impedances when a voltage E_M was acting in a resistance replacing the microphone.
- V_L The voltage across the line terminals under the same conditions as for measuring V_{ST} .
- V_R The voltage across the receiver when the line impedance was L and a voltage E_L was applied in the line.

All the above measurements were made at 1100 p/s, but to complete the data Z_L and L were measured over a range of frequencies.

All voltage measurements were made by comparing the two voltages concerned (of which the ratio only was important) by means of a detector and a variable attenuator; the arrangement is shown in Fig. 4.

Figs. 5 and 6 show the values of Z_L (line terminal impedance) and L (no side tone line impedance) at different frequencies, in order to illustrate the amount of diversity between present day sets.

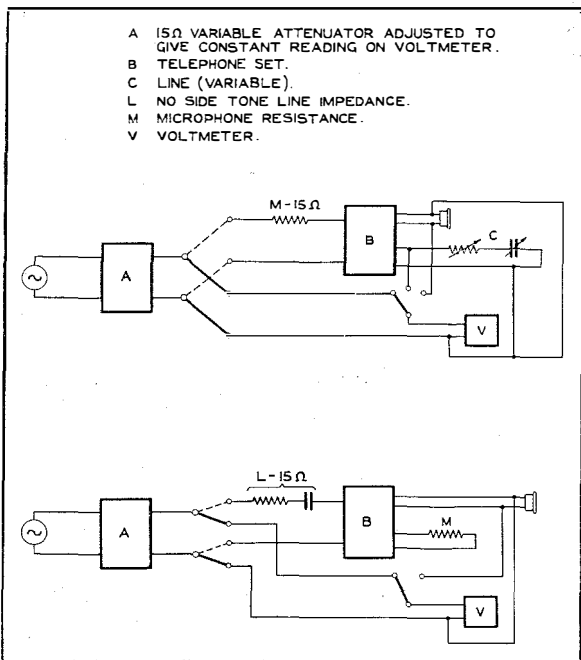

Figure 4—Measurement of Line Voltage V_L and Side Tone Voltage V_{ST} (Upper Schematic).
Measurement of Received Voltage V_R from Line (Lower Schematic).

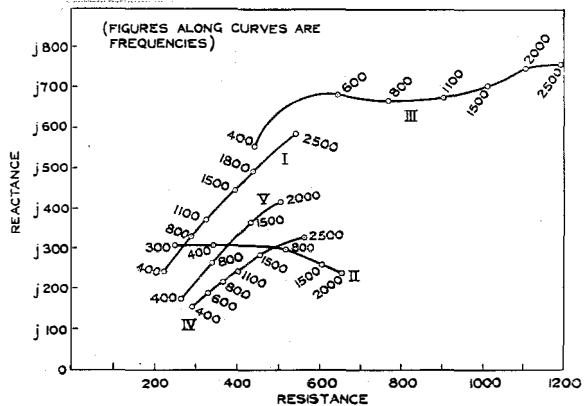

Figure 5— Z_L —Impedance at Line Terminals of Sets Tested.

Fig. 7 shows the side tone reduction compared with the ideal side tone set for each set plotted against modulus of line impedance, selected for maximum or minimum rate of change of side tone: it has been explained that the purpose of this paper is to show the harmony that in reality exists between these different characteristic curves.

The experimental procedure for determining side tone was to adjust the variable attenuator to give a convenient open circuit voltage reading on the voltmeter, and then to readjust the attenuator to give the same deflection on the voltmeter connected first across the line and then across the receiver. These measurements were made for a number of line impedances $L + \Delta L$, with ΔL selected to have the same angle as $Z_L + L$.

A similar procedure was followed in measuring the receiving efficiency from line L .

The side tone power is $\frac{V_{ST}^2}{|R|} \cos \theta$, where θ is the angle of the receiver impedance.

The side tone of an ideal side tone set is

$$\text{(equation B.1) } \frac{E_M^2}{16M}$$

Hence the side tone power reduction is:

$$\frac{V_{ST}^2}{E_M^2} \frac{16M \cos \theta}{|R|} \dots \dots \dots 7.$$

The ratio V_{ST}^2/E_M^2 is given by the difference of two attenuator settings, and the remaining fraction is then calculated, expressed as decibels, and added.

The side tone reduction for an ideal anti-side tone set is taken directly from the curve of Fig. 1 (ΔL real) after calculating the ratio $2\Delta L/(Z_L+L)$.

Tables I to V give the results of the side tone measurements compared with the side tone reduction for the ideal set obtained as described.

The tabulated figures support the conclusion that the shape of the side tone reduction curve, when the line impedance varies in such a direction as to give the maximum or minimum side tone for a given modulus of L , is the function of $2\Delta L/(Z_L+L)$ plotted in Fig. 1.

Having determined the shape of the side tone characteristic of a commercial set, it remains to ascertain the amount by which this characteristic is displaced from the ideal anti-side tone characteristic. Equation 1 shows the side tone reduction to be a function of the transmitting and receiving efficiency and the line impedance. To illustrate and verify this equation, the side tone for one particular line impedance with each set has been calculated and compared with the measured value.

Table VI gives transmitting and receiving efficiencies, η_M and η_R calculated from (A.8)

TABLE V
SET No. 5
 $Z_L = 407 + j 267$ $L = 500$

ΔL	$L + \Delta L$	$\frac{2\Delta L}{Z_L+L}$	Side Tone Power Below Ideal Side Tone Set		Difference
			Observed	Ideal	
100	600	.21	db. -27.4	db. -20.4	db. 7.0
200	700	.42	-22.6	-15.3	7.3
300	800	.63	-19.9	-12.4	7.5
400	900	.84	-18.1	-10.6	7.5
-100 - j 30	400 - j 30	-.22	-26.9	-18.0	8.9
-200 - j 60	300 - j 60	-.44	-19.3	-11.0	8.3
-300 - j 90	200 - j 90	-.66	-14.1	-6.1	8.0
-400 - j 120	100 - j 120	-.88	-10.1	-2.2	7.9
	Open Circuit	-	- 8.3	-	
AVERAGE					7.8

Note: Small positive reactances in $L + \Delta L$ omitted for experimental convenience; the error introduced is negligible.

TABLE VI
RELATION BETWEEN SIDE TONE REDUCTION AND TRANSMITTING AND RECEIVING EFFICIENCY

Set No.	ΔL	$L + \Delta L$	η_M db.	η_R db.	$\frac{(\Delta L)^2}{4L_r(L + \Delta L)_r}$ db.	Side Tone From Sum of Preceding Three Columns db.	Observed Side Tone db.	$\eta_M + \eta_R$	Average Side Tone Reduction From Tables I-V
II.	500 - j 70	1062 - j 470	-2.0	-4.1	-9.9	-16.0	-16.0	-6.1	-6.1
III.	400 + j 114	1328 - j 44	+2.5	-4.5	-14.5	-16.5	-17.4	-2.0	-2.5
IV.	500 + j 130	1036 + j 130	-2.1	-2.6	-9.2	-13.9	-14.1	-4.7	-4.8
V.	400	900 + j 120	-4.7	-3.5	-10.5	-18.7	-18.1	-8.2	-7.8

Note: The above efficiency figures are not to be taken as exactly indicative of the relative efficiencies of the sets in practice, because, apart from being single frequency measurements, they depend on the particular microphone and line impedances assumed. In Set No. 3 also, as in other cases, the measurements were made without superposed d-c., in most cases this would make little difference, but in Set No. 3 the receiver impedance is considerably affected.

and (A.11), in which Z_{ML} and Z_{LR} are easily obtained from the measured voltage ratios $E_M/V_{L+\Delta L}$ and E_L/V_R by the relations:

$$Z_{ML} = \frac{E_M}{V_{L+\Delta L}} \left(\frac{Z_L + L}{Z_L + L + \Delta L} \right) (L + \Delta L) \dots 8.$$

$$Z_{LR} = \frac{E_L}{V_R} R. \dots \dots \dots 9.$$

The product of transmitting and receiving efficiency and the factor $\frac{(\Delta L)^2}{4L_r(L + \Delta L)_r}$, (equation

1), is seen to agree closely with the measured side tone reduction, and the average constant side tone reduction below the ideal anti-side tone set is closely in agreement with the sum of the transmitting and receiving efficiencies.

Summary

The facts that have been disclosed in this article may be summarised as follows:

1. The side tone reduction of any anti-side tone set circuit at any one frequency and for any line impedance is determined completely by the transmitting and receiving efficiency of the circuit (under specified conditions) and the no-side tone line impedance. (See equation 1 and Table VI).
2. With varying line impedance, the side tone is a constant number of decibels lower than the side tone of an ideal anti-side tone set (see expressions 3 to 6, and Tables I to V), provided the comparison is made for equal values of $L/\Delta L$ in the ideal set, and $2\Delta L/(Z_L+L)$ in the commercial set.
3. The constant difference between the side tone reduction of an ideal and a commercial set is equal to the number of decibels by which the transmitting and receiving efficiency together are below an ideal set; the transmitting efficiency is related to the condition of line $(L + \Delta L)$, and the receiving efficiency to the constant condition of line L . (See Table VI and compare expressions 1 and A.14).

APPENDIX A

Side Tone Related to the Network Efficiency

Consider an anti-side tone set with an e.m.f. in the microphone circuit and connected at its line terminals to the impedance for which there is no side tone in the receiver.

The current in the line circuit will be

$$\frac{E_M}{Z_{ML}} \dots \dots \dots (A.1).$$

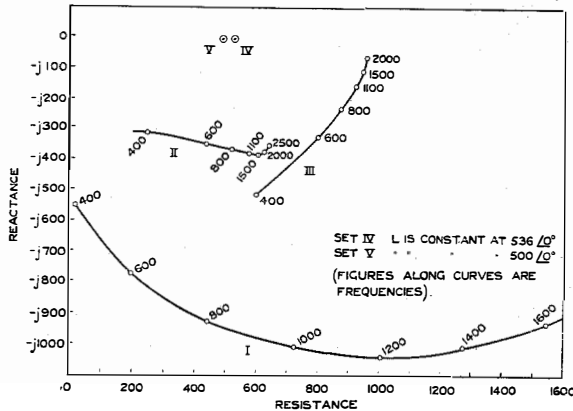

Figure 6—No-Side Tone Line Impedance for Sets Tested.

The e.m.f. in the line circuit will be

$$\frac{E_M}{Z_{ML}} (Z_L + L) \dots \dots \dots (A.2),$$

and, therefore, if the line impedance is changed to $L + \Delta L$ the line current will be

$$\frac{E_M}{Z_{ML}} \left(\frac{Z_L + L}{Z_L + L + \Delta L} \right) \dots \dots \dots (A.3).$$

The network currents will all be precisely the same if instead of changing the line impedance to $L + \Delta L$ it is maintained at the value L , and a voltage E'_L is introduced in the line circuit of such an amount that the line current assumes the value (A.3), i.e.,

$$\frac{\frac{E_M}{Z_{ML}} (Z_L + L) + E'_L}{Z_L + L} = \frac{E_M}{Z_{ML}} \frac{(Z_L + L)}{(Z_L + L + \Delta L)},$$

whence $E'_L = - \frac{E_M}{Z_{ML}} \left(\frac{Z_L + L}{Z_L + L + \Delta L} \right) \Delta L \dots (A.4).$

The voltage E'_L in the line circuit will produce a current in the receiver, and since all the network currents are the same as would have existed without E'_L if the line impedance had been $L + \Delta L$, it follows that the current in the receiver caused by E'_L is the side tone current produced by E_M when the line impedance is $L + \Delta L$.

The current in the receiver due to E'_L is: side tone current =

$$\frac{E'_L}{Z_{LR}} = - \frac{E_M}{Z_{ML} Z_{LR}} \left(\frac{Z_L + L}{Z_L + L + \Delta L} \right) \Delta L \dots (A.5).$$

This may be expressed as follows, noting that (A.3) expresses the current transmitted to line $L + \Delta L$, and that $\frac{1}{Z_{LR}}$ is the current in the receiver per volt in line L :

The side tone current when the line is $L + \Delta L$ is equal to the product of three factors: (a) ΔL ; (b) the transmitted current to line $L + \Delta L$; and (c) the current in the receiver per volt in line L .

To obtain a corresponding formula in terms of power efficiency, let subscript r denote the real part of any impedance to which it is appended.

The e.m.f. in the line circuit ($Z_L + L$) due to E_M in the microphone is

$$\frac{E_M}{Z_{ML}} (Z_L + L) \dots \dots \dots (A.6),$$

and the power delivered to line $(L + \Delta L)$ is

$$\frac{E_M^2}{Z_{ML}^2} \left(\frac{Z_L + L}{Z_L + L + \Delta L} \right)^2 (L + \Delta L)_r \dots (A.7).$$

But the power to line in an ideal set = $E_M^2/8M$; hence the transmitting efficiency for line $(L + \Delta L)$ is

$$\eta_M = \frac{8M}{Z_{ML}^2} \left(\frac{Z_L + L}{Z_L + L + \Delta L} \right)^2 (L + \Delta L)_r \dots (A.8).$$

The receiver power for E_L in line L is

$$\left(\frac{E_L}{Z_{LR}} \right)^2 R_r \dots \dots \dots (A.9),$$

and for an ideal set receiving from line L the received power is

$$\frac{E_L^2}{8L_r} \dots \dots \dots (A.10),$$

so that the receiving efficiency from line L is

$$\eta_R = \frac{8 R_r L_r}{Z_{LR}^2} \dots \dots \dots (A.11).$$

Obtaining the side tone power from (A.5), and dividing it by the side tone power $E_M^2/16M$ of an ideal side tone set, it is found that the side tone "efficiency" is

$$\eta_{ST} = \frac{16 M R_r}{Z_{ML}^2 Z_{LR}^2} \left(\frac{Z_L + L}{Z_L + L + \Delta L} \right)^2 (\Delta L)^2 \dots (A.11).$$

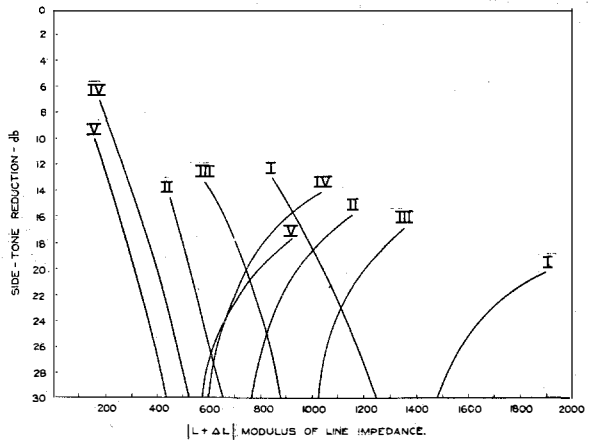

Figure 7—Side Tone Reduction Against Modulus of Selected Line Impedance for Sets Tested.

Collecting together (A.8), (A.11), and (A.12), it is found that

$$\eta_{ST} = \eta_M \eta_R \frac{(\Delta L)^2}{4L_r (L + \Delta L)_r} \dots (A.13).$$

It should be noted that η_M is not a constant but is a quantity that varies with the line $(L + \Delta L)$; η_R is a constant for the set independent of the actual line, and would be unity in an ideal anti-side tone set, whereas η_M would then be:

$$\frac{4 L_r (L + \Delta L)_r}{(Z_L + L + \Delta L)^2} \dots \dots \dots (A.14).$$

APPENDIX B

IDEAL SIDE TONE

Side Tone Set

In an ideal side tone set, one-fourth of the total power produced is absorbed in the microphone, one-fourth in the receiver, and one-half is delivered to the line; for simplicity, the ideal set may be regarded as a series circuit with microphone resistance M , receiver resistance $R = M$, and line resistance $L = 2 M$.

The current will then be $E_M/4 M$, and the power in the receiver will be

$$\frac{E_M^2}{16 M} \dots \dots \dots (B.1).$$

This is the side tone power in the receiver of an ideal set, but it must be noticed that when the

line impedance changes, the set itself is supposed to be changed, as for example by putting a transformer between line and set so that the combination remains ideal.

Anti-Side Tone Set

In an ideal anti-side tone set, L, Z_L, M, and R are pure resistances, with L = Z_L. With an e.m.f. E_L in the line, all the power given to the set is dissipated in the microphone and receiver, and is divided equally between them. Expressing this in symbols with E_L as the e.m.f. in the line circuit, and E_L/2 for the voltage at the telephone set line terminals (since in the ideal set Z_L = L)

$$\frac{E_L^2}{4 Z_L} = \left(\frac{E_L}{Z_{ML}}\right)^2 M + \left(\frac{E_L}{Z_{LR}}\right)^2 R \dots (B.2),*$$

$$\frac{M}{Z_{ML}^2} = \frac{R}{Z_{LR}^2} \dots (B.3).$$

From (B.2) and (B.3),

$$Z_{ML} = 2\sqrt{2} M Z_L \dots (B.4),$$

$$Z_{LR} = 2\sqrt{2} R Z_L \dots (B.5).$$

Now the side tone current in the receiver is given by (A.5), and for the ideal set L is to be made equal to Z_L and the values in (B.4) and (B.5) are to be substituted. The side tone current for an ideal anti-side tone set is therefore

$$\frac{-E_M}{4 \sqrt{MR}} \frac{\Delta L}{2 Z_L + \Delta L} \dots (B.6),$$

and the power given to the receiver is

$$\frac{E_M^2}{16 M} \left(\frac{\Delta L}{2 Z_L + \Delta L}\right)^2 \dots (B.7).$$

By comparison with (B.1), the side tone power reduction, taking an ideal side tone circuit as the basis of comparison, is expressed by the fraction

$$\left(\frac{\Delta L}{2 Z_L + \Delta L}\right)^2$$

or, on dividing numerator and denominator by Z_L² or L² (since Z_L = L):

$$\left(\frac{\Delta L/Z_L}{2 + \Delta L/Z_L}\right)^2 \text{ or } \left(\frac{\Delta L/L}{2 + \Delta L/L}\right)^2 \dots (B.8).$$

* Use is made in this equation of the fact that the transfer impedance Z_{Ml} equals the transfer impedance Z_{Lm}.

Thus a family of curves can be drawn for an ideal anti-side tone set showing the side tone reduction in terms of ΔL/L, ΔL being complex in general. One curve is unique, namely, that for which ΔL is real. This curve is shown in Fig. 1, and as may be seen by study of (B.8), its two branches are curves of maximum and minimum side tone for any given modulus of ΔL/L.

APPENDIX C

CIRCULAR LOCI FOR SIDE TONE CURRENTS

By equation (A.5), the side tone current in any telephone set for E_M = 1 is:

$$i = - \frac{1}{Z_{ML} Z_{LR}} \left(\frac{Z_L + L}{Z_L + L + \Delta L}\right) \Delta L \dots (C.1).$$

From which it may be calculated that

$$\Delta L = \frac{i Z_{ML} Z_{LR} (Z_L + L)}{-(Z_L + L) - i Z_{ML} Z_{LR}} \dots (C.2).$$

If the reactance component of ΔL be plotted against the real component for values of i which are constant in amplitude but different in phase, the plot will be a circle for each value of constant |i|.

The centres and radii of the circles will be:

$$\text{Centre: } \frac{- |Z_{ML}^2 Z_{LR}^2| (Z_L + L) i^2}{|(Z_L + L)^2| - |Z_{ML}^2 Z_{LR}^2| i^2} \dots (C.3),$$

$$\text{Radius: } \frac{(Z_L + L)^2 Z_{ML} Z_{LR} i}{|(Z_L + L)^2| - |Z_{ML}^2 Z_{LR}^2| i^2} \dots (C.4).$$

The circle for zero side tone, which reduces to a point at the origin, and the centres of all the circles will lie on a straight line making with the real axis an angle equal to the angle of the impedance (Z_L + L).

The constant side tone loci form a system of non-intersecting circles whose centres are co-linear: it follows that the intersection of the circles with the line of centres gives a scale of side tone values corresponding to ΔL varying in magnitude with the constant angle φ. It may also be deduced that φ and φ + π are the angles for which with a given amount of side

tone, $|\Delta L|$ can have the greatest and smallest values.

Conversely, for a given value of ΔL , the maximum and minimum side tone occur when the argument of ΔL is $\phi + \pi$ and ϕ , respectively.

Further, if ΔL has the angle ϕ or $(\phi + \pi)$, $\Delta L / (Z_L + L)$ will be a real quantity. The investigation of side tone, therefore, for ΔL at the angle ϕ or $\phi + \pi$ is of fundamental interest because it discloses maximum and minimum values which may be compared directly with the corresponding maximum and minimum curves (Fig. 1) for the ideal anti-side tone set.

General Symbols

L	Line impedance for which there is no side tone.
ΔL	Difference between L and any actual line impedance.
M	Microphone impedance.
R	Receiver impedance.
Z_L	Line terminal impedance of the telephone set.
E_L	Any e.m.f. in the line.
E_M	Microphone e.m.f.
V_R	Volts across the receiver due to a voltage in the line.
V_{ST}	Side tone volts across the receiver due to a voltage in the microphone.
Z_{ML}	Transfer impedance between microphone circuit and line circuit when the line impedance is L .
Z_{LR}	Transfer impedance between line circuit and receiver circuit when the line impedance is L .

Automatic Receiver for Distress Signals

By O. BRACKE and P. GIROUD

Les Laboratoires Le Matériel Téléphonique, Paris

Introduction

ACCORDING to their classification and importance, all sea-going ships are compelled to have one, two, or three wireless operators on board, who, under the Merchant Shipping Act of 1927, are to keep a wireless watch during certain hours imposed by the rules laid down in the Act.

Outside these watch-keeping periods, the ships have been unable to receive distress signals. To obviate this inconvenience and in order to reduce the number of required wireless operators, the Washington International Wireless Telegraphy Convention of 1927, instituted the "automatic distress signal" which precedes the ordinary distress signals.

The "automatic distress signal" is transmitted on a wavelength of 600 meters. It consists of a series of twelve dashes sent out in one minute. The duration of each dash is four seconds, with a one second interval between dashes.

The only purpose of this special signal is to set in operation the automatic receiving apparatus which gives warning of the receipt of a distress call when watch is not being kept by an operator. It is used solely to announce that the distress call or message is about to follow.

The automatic distress signal may be sent out either automatically or manually. For the latter case, it is generally required that the auto-alarm equipment shall be capable of receiving signals within certain limits. The duration of each dash may vary between 3.5 and 4.5 seconds, and the duration of the intervals between 0.2 and 1.2 seconds.

The automatic instruments used for receiving the alarm signals must satisfy the following conditions:

- (1) They must respond to the alarm signal after three consecutive dashes, even when numerous transmitting stations are working and when there is atmospheric interference;
- (2) They must not be started by atmospheric or by powerful signals other than the alarm signal;
- (3) They must possess a sensitivity equal to that of a

crystal detector receiver connected with the same antenna;

- (4) They must give warning when their operation ceases to be normal.

To comply with the aforesaid regulations, the Laboratories have recently developed an automatic receiver for distress signals of a new type. This equipment has been approved by the General Post Office of Great Britain for installation on board of compulsorily fitted ships and it has been standardised by the International Marine Radio Company, Ltd.

This article describes the equipment known as the A.A.2.B. Auto-Alarm.

Signal Time Checking

Numerous types of automatic receivers have been developed by different firms, the signal time checking being done by tuned relays, pendulum clock systems, or clutch or motor driven switches. All of them are based on the principle of the direct measurement of the duration of each individual dash and interval.

The duration of the dashes is a relatively stable element; atmospheric interference or powerful signals other than alarm signals can only add to their duration without changing their characteristics. The intervals which, according to the regulations, may be as short as 0.2 second are, on the contrary, liable to be upset to a greater extent by the interferences. Consequently, under normal service conditions, two consecutive dashes are not separated by an interval of the correct duration but by an interval containing a number of extraneous short signals as shown in the following diagram:

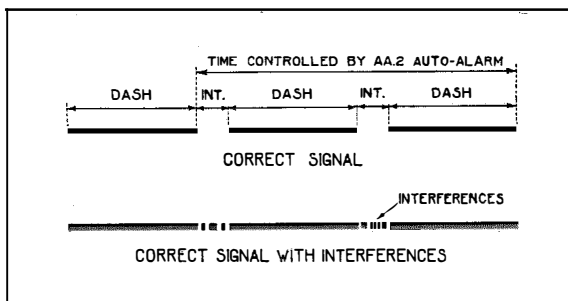

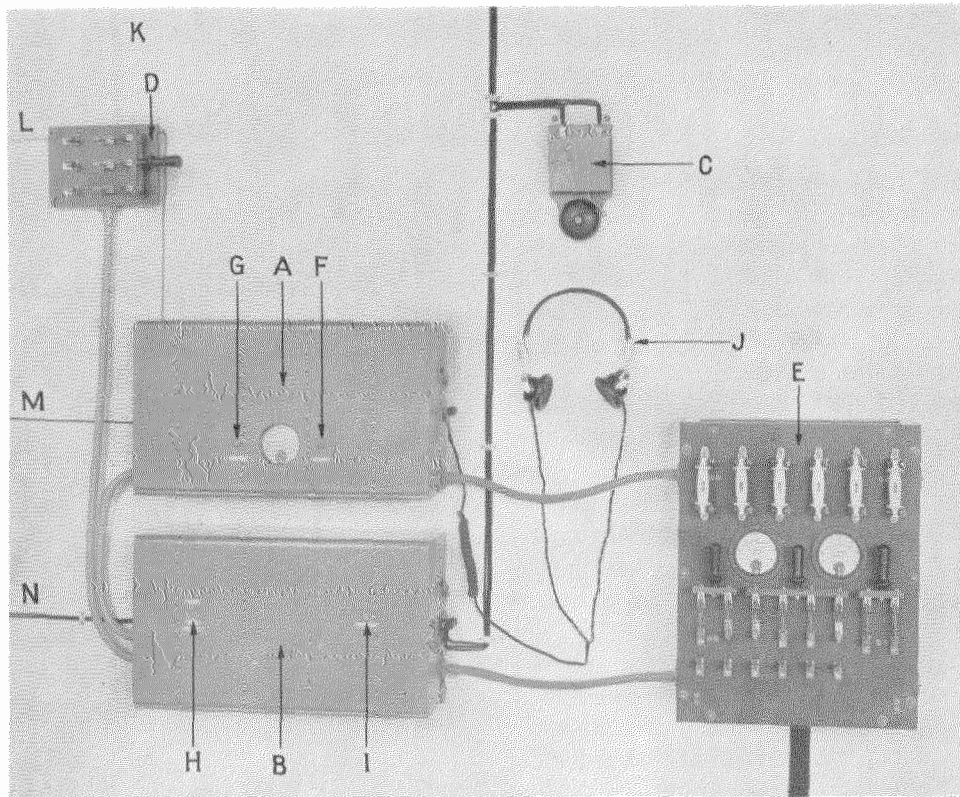

Figure 1—A.A.2.B. Auto-Alarm Assembly:

A—Receiver.
 B—Selector.
 C—Alarm Bell.
 D—Antenna Change-Over Switch.
 E—Charging Panel.
 F—Test Key.
 G—Alarm Bell Control Key.

H—Signal Transmission Key.
 I—Alarm Circuit Release Key.
 J—Head Receiver.
 K—To Antenna.
 L—To Normal Receiver.
 M—To Ground.
 N—To Transmitter.

By eliminating the measurement of the interval separating two consecutive dashes and substituting a check of the total time from the end of a first dash to the end of the following second consecutive dash, the new auto-alarm developed by the Laboratories completely solves the problem. The principal cause of failure of the other types of automatic distress signal receivers is suppressed.

Description

The equipment is illustrated in Fig. 1. It consists of:

- (1) A watertight box containing the wireless receiver;
- (2) A similar box containing the signal selector device;
- (3) Three alarm bells;

(4) An antenna change-over switch;

(5) Two individual power supply batteries and charging panel.

Wireless Receiver

The wireless receiver, illustrated in Fig. 2, responds without readjustment to signals on wavelengths between 585 and 615 metres.

The circuit consists of a stage of high frequency amplification, a detector stage, a stage of low frequency amplification, and a low frequency detector.

The valves are of the indirectly heated type, the heater current being regulated by a ballast lamp which compensates a variation of battery

between 22 and 26 volts, the normal voltage being 24 volts.

A relay connected in the plate circuit of the low frequency detector valve operates the selector device, whenever a radio signal of required frequency is received.

A safety relay is connected in the plate circuit of the second and third valves and operates the alarm bell circuit whenever the receiver ceases to work, either by reason of failure of a valve, or because of failure of the batteries. This relay otherwise has no direct action on the operation of the auto-alarm device.

A testing buzzer controlled by a push button key located in front of the receiver case is provided to test the working of the complete installation by local excitation.

A special non-locking key is also provided so that, when desired, the bridge alarm bell can be prevented from ringing when the alarm is being tested by local excitation. Release of this key

automatically reestablishes the circuit of the bridge alarm bell.

The complete unit is enclosed in a watertight box which is so arranged as to be bulkhead or table mounted. The front of the box is hinged at the bottom. When it is open, the whole unit is readily accessible.

Signal Selector

The signal selector is illustrated in Fig. 3. It registers the genuine distress signals and rejects all other signals produced by transmitting stations or atmospheric interferences. It chiefly consists of:

- (1) A bank of relays;
- (2) A constant speed motor and reduction gear;
- (3) A time measuring device.

The selector also contains a signal transmission device.

Relay Bank

The relay bank, composed of a mounting

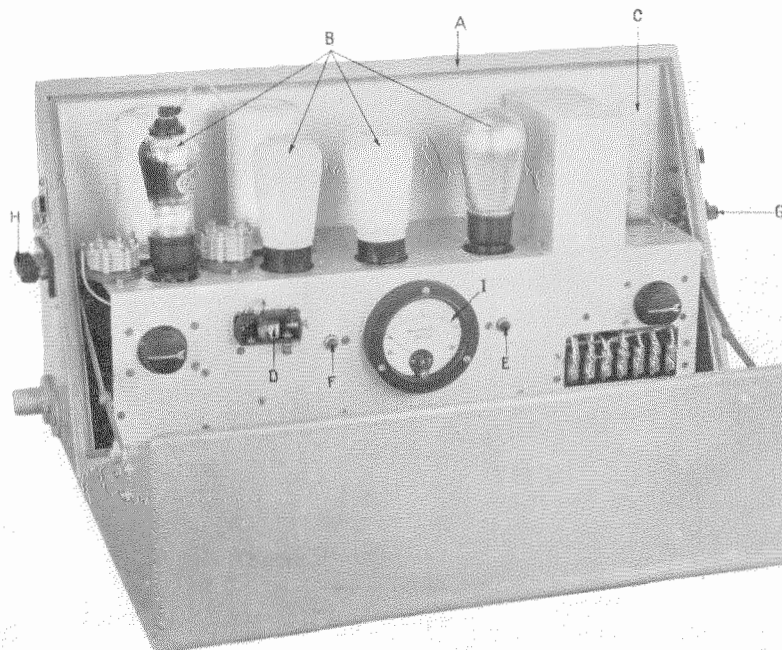

Figure 2—Wireless Receiver Unit (Open):

A—Watertight Box.
B—Valves.
C—Ballast Lamp.
D—Testing Buzzer.
E—Test Key.

F—Alarm Bell Control Key.
G—Head Receiver Terminals.
H—Antenna and Ground Connecting Terminal Block.
I—Second Detector Plate Current Milliammeter.

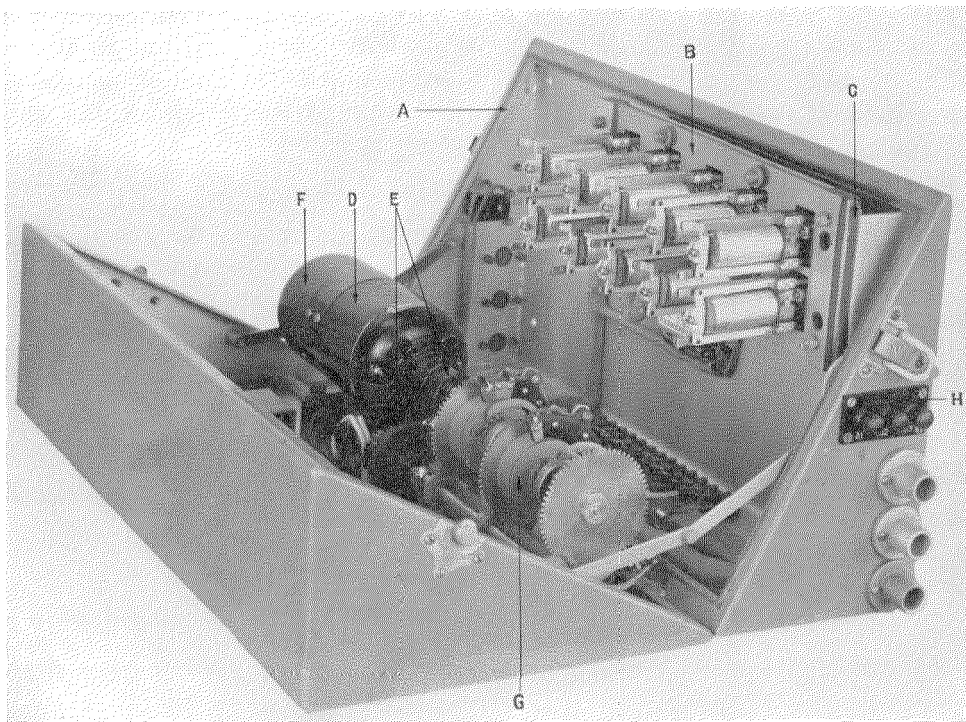

Figure 3—Signal Selector Unit (Open):

A—Watertight Box.
 B—Relay Bank.
 C—Elastic Relay Bank Mounting.
 D—Constant Speed Motor.

E—Speed Reduction Gear.
 F—Automatic Speed Regulator.
 G—Time Measuring Mechanism.
 H—Alarm Bell Terminal Block.

plate with an assembly of ten relays, is elastically mounted by means of rubber pads on another plate which in turn is hinged to a small support fastened to the rear part of the containing box. By swinging the hinged plate, easy access is obtained to the soldering lugs of the relays and to the cable form.

The ten relays are in three groups. The first is a group of counting relays which register three consecutive dashes of the distress signal. The second group of relays controls the resetting at zero position of the first time-measuring switch when signals other than distress signals are received. The third and last group of relays controls and blocks the alarm bell circuit after a correct distress signal has been registered. The alarm bell circuit can only be released by a non-locking push button key provided for this purpose on the front of the selector box.

Driving Motor

The driving motor is of the series wound type and is permanently rotating when the equipment is in operation. It is provided with a governor keeping the speed constant at 1,617 R.P.M. $\pm 2\%$ and a reduction gear device which reduces the speed to 10.1 R.P.M. To give a signal when the motor speed falls below a given value, a special contact incorporated in the automatic governor controls an alarm-bell circuit.

Time Measuring Mechanism

The time measuring mechanism (Fig. 4) is composed of a small frame on which two special timing switches are mounted. In line with the timing switches and on the same frame, the signal transmission commutator is assembled. The two timing switches and the signal trans-

mission commutator are driven by means of gears fixed on a driving shaft mounted on the frame by two self-aligning bearings. The whole unit is mounted in the selector box and coupled to the motor shaft by means of the reduction gear.

The first switch discriminates among the correct and incorrect received signal dashes and controls, by means of its different contacts, either the counting relays or the releasing and resetting relays.

The second switch verifies the maximum duration admissible for the correct consecutive signal dashes and intervals to be recorded.

For the transmission of alarm-signals, the permanently connected transmission commutator takes the place of the transmitting key and operates in conjunction with the ship's transmitting equipment. Alarm signals are auto-

matically transmitted by the simple process of depressing a key mounted in front of the selector box. This operation can be executed whether the equipment is in the operating position or at rest. The simplicity of starting the alarm transmission is such that the ship is not entirely dependent on its operator in time of distress. It provides means for an abandoned ship to continue to send out the distress alarm signal, thereby increasing the chances of other ships locating her and the lifeboats by means of their direction finders.

Timing Switch

The timing switch is illustrated in detail in Fig. 5. It consists of a small frame to which the following parts are assembled:

(a) A spindle on which are mounted a magnetic clutch with its driven gear, the contact

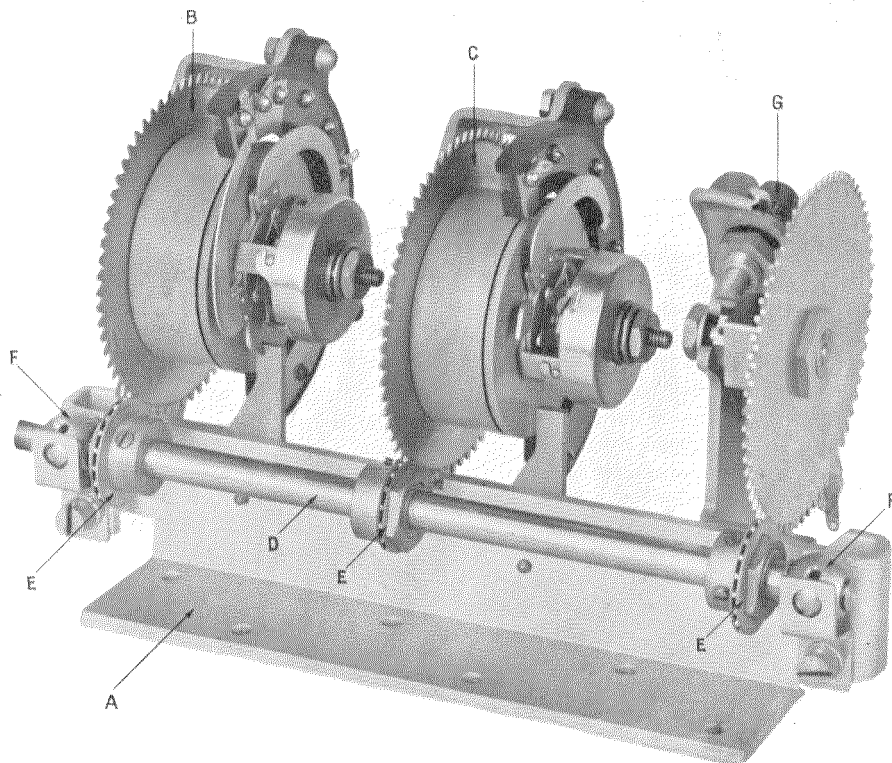

Figure 4—Time Measuring Mechanism—Assembly:

A—Supporting Frame.
B—First Timing Switch.
C—Second Timing Switch.
D—Driving Shaft.

E—Driving Gears.
F—Self-Aligning Bearings.
G—Signal Transmission Commutator.

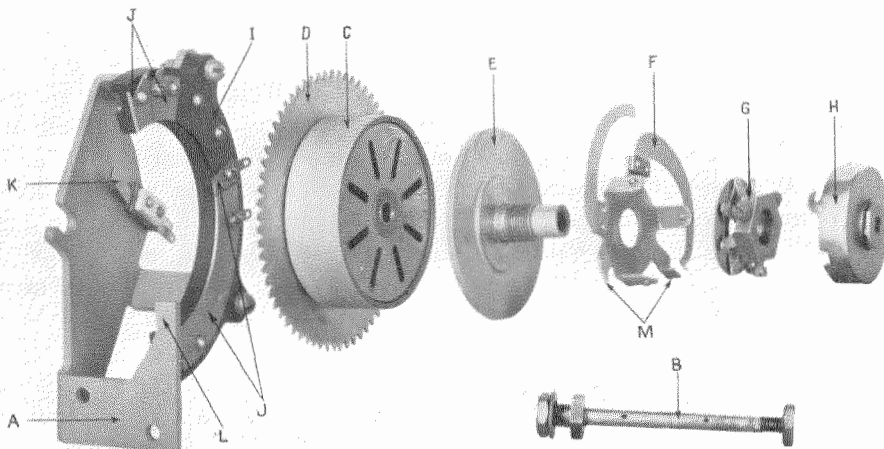

Figure 5—Timing Switch (Details):

A—Frame.
 B—Spindle.
 C—Clutch Magnet.
 D—Driven Gear.
 E—Clutch Armature.
 F—Contact Brush Assembly.
 G—Friction Spring and Adjusting Nut.

H—Main Spiral Resetting Spring and Housing.
 I—Insulated Arc.
 J—Contact Segments.
 K—Feeder Brush.
 L—Stop.
 M—Travel Limiting Stopping Lug.

brushes, the friction spring, and the main spiral resetting spring.

The driven gear attached to the clutch magnet is permanently in gear with the driving gear on the main shaft and consequently keeps the clutch magnet in continuous rotation.

The clutch armature is freely mounted on the spindle and rotates when attracted by the magnet. It drives, under the pressure of the friction spring, a plate to which the contact brush assembly is rivetted.

The pressure of the friction spring is adjusted by means of a nut which in turn is securely locked in position on the armature by means of three set screws. The main spiral resetting spring is located in a small housing hooked to the armature by means of a bayonet joint. One end of the spring is fastened to the spring housing and the other end to a hub fixed at the end of the spindle. When the clutch armature is attracted and rotates it carries the contact brush assembly with it and winds up the resetting spring.

(b) An insulated arc on which are assembled the metallic sectors upon which the contact brushes driven by the magnetic clutch make contact.

(c) A contact spring used as a feeder brush for the magnetic clutch.

The operation of the timing switches is as follows:

When the clutch magnet is energized by the relay controlled by the low frequency detector of the receiver, the clutch armature is attracted and starts rotating instantaneously with the constantly rotating magnet. The armature drives the contact brush assembly under the pressure of the friction spring and rotates it 90° or 185°, depending on whether the first or the second switch is involved. At the end of the movement, a special lug on the brush member butts against a stop provided on the frame and stops the rotation of the brush member. The contact brush assembly now slips, although the armature still rotates as long as the magnet is energized. When the clutch magnet is deenergized, it releases the armatures and brush member. These return to their initial position under the action of the resetting spring which has been wound up by the forward rotation of the brush member. The resetting movement of the armature and brush member is stopped when the lug on the brush member reaches the home position back-stop on the frame. There is no rebound as the brush

member is kept against the back-stop by the inertia of the armature which, sliding on the brush member, continues to rotate for a short period. Due to this principle adopted in the design of the switch, the latter has the great advantage of starting rotation instantaneously when the magnet is energised and of returning to its correct home position without rebounding. The last point is particularly important since it is absolutely essential that, if the switch has to start almost instantaneously after having come back to its home position, it should really start from its home position and not from any other position of rebound, as in this case a wrong signal might be registered or a correct one rejected.

Alarm Bells

Three alarm bells are required by the statutory rules of the Merchant Shipping Act: One of these alarm bells is provided in the wireless telegraph room, one in the wireless operator's cabin, and

one in the captain's quarters on the bridge. The latter can be prevented from ringing when the complete outfit is being tested by depressing the special key provided for this purpose on the receiver.

Antenna Change-Over Switch

A three-pole change-over switch is provided for changing over from normal reception to auto-alarm reception.

This switch is so connected that one pole transfers the ship's antenna from the normal receiver to the auto-alarm receiver. The two other poles control, respectively, the power supply for the receiver and relay circuit and the power supply for the motor.

Power Supply and Charging Panel

The power supply consists of a low tension battery of 24 volts, the current drain for the receiver and selector being approximately 2.5 amperes, and a high tension battery of 120 volts,

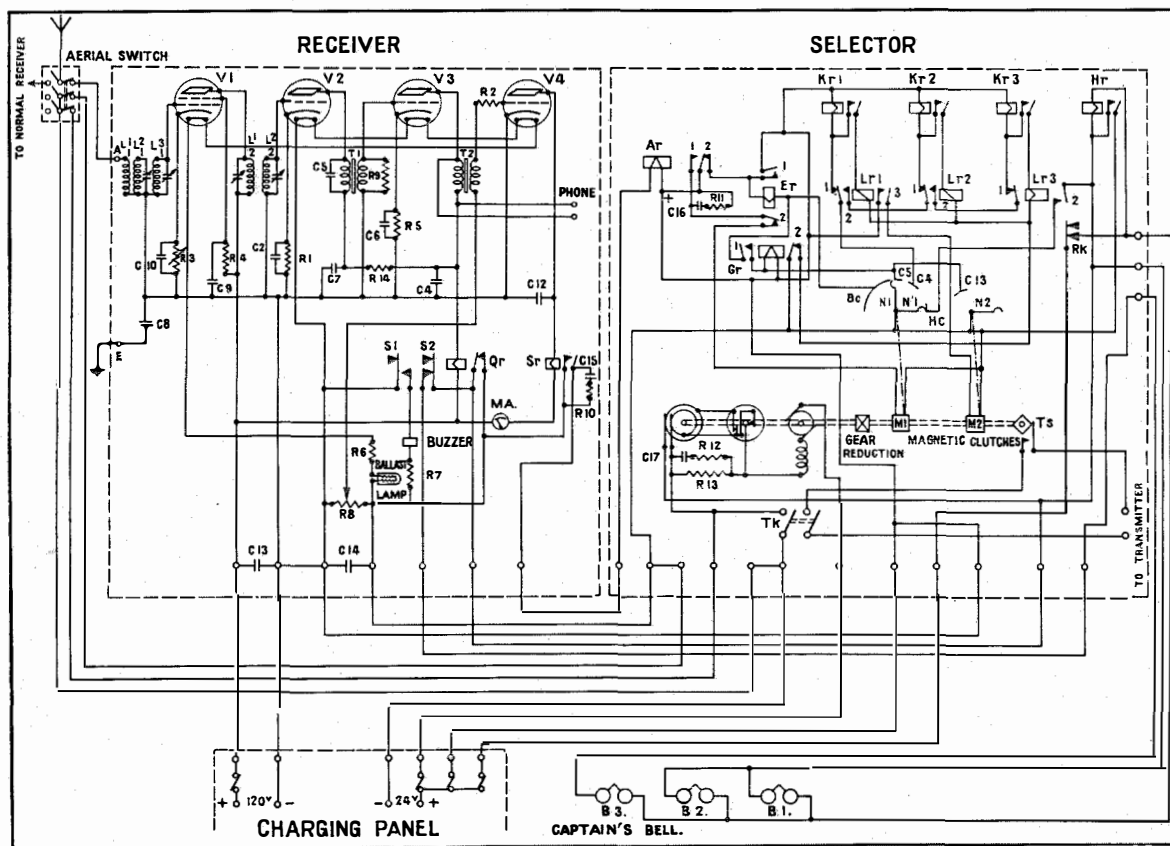

Figure 6—Circuit Schematic of A.A.2.B. Type Auto-Alarm.

the current drain for the receiver being approximately 0.025 ampere.

A spare low and high tension battery is furnished as a standby.

The charging panel is for operation from the ship's mains and includes all the necessary fuses, switches, and meters.

Operation

Before explaining in detail the operation, it is necessary to consider the various possibilities which may arise while the equipment is in service and ready to receive the distress signal.

The possibilities are as follows:

- (1) First dash of correct duration;
- (2) Second dash of correct duration;
- (3) Third dash of correct duration;
- (4) Dash of too short a duration;
- (5) Dash of too long a duration;
- (6) Spurious dashes of correct duration;
- (7) Distress signals superimposed on other signals.

Possibilities (1), (2), and (3) correspond to the case of reception of a correct distress alarm signal not marred by any interference.

Possibilities (4), (5), and (6) correspond to the case of reception of a spurious signal mixed with interferences or atmospheric.

Possibility (7) corresponds to the case of reception of a correct distress alarm signal on which are superimposed other signals or atmospheric.

The general schematic of the A.A.2. auto-alarm is shown in Fig. 6. It is assumed that the receiver and selector mechanism have been switched on by throwing the antenna change-over switch to the operating position. The equipment is ready for operation after the short time necessary for the indirectly heated valves to be warmed up.

(1) *First Dash of Correct Duration.* When the first dash of a distress signal is received, the rectified current corresponding to this first dash energises relay Sr which pulls up and operates in turn the input relay Ar of the selector. The electromagnet of the first timing switch M1 is energised and the contact brushes N1 and N'1 start rotating. Contact brush N1 connects negative potential to the contact segment BC maintaining the contact on same during the time of rotation of arm N1 either way. The

other brush N'1 leaves the home contact segment HC. After 3.5 seconds it reaches segment C4 and energises relay Kr1 which operates and through its front contact is placed in series with the winding of relay Lr1 which is short-circuited and therefore does not operate.

As it is assumed that the received dash is of correct length, it will cease while the brush N'1 is still on segment C4 and before it reaches segment C5.

Segment C5 is located on the arc in such a position that the time brush reaches this contact after 4.5 seconds.

Relay Sr will release at the end of the dash, as will also relay Ar. The magnetic clutch M1 being deenergised, brushes N1 and N'1 will return to their home position under the influence of the resetting spring.

As soon as the brush N'1 leaves the segment C4, relay Lr1 is no longer short-circuited. It becomes energised and causes the following operations:

- (a) By means of its contact 2, it transfers segment C4 to the second group of counting relays Kr2 and Lr2 in order to allow the recording of the second dash, provided this dash be of correct duration.
- (b) Through its contact 3, it energises the magnetic clutch M2 and the timing brush N2 starts rotating.

(2) *Second Dash of Correct Duration.* When a second dash of correct duration, succeeding a first correct signal, is received, the cycle of operations described above will again take place, but instead of energising relay Kr1, the brush N'1 now energises relay Kr2.

When the second signal ceases, the time-arm N'1 leaves the segment C4, and relay Kr2 locks up in series with the winding of Lr2 which operates.

By means of the front contact of relay Lr2, segment C4 is now connected to the third group of counting relays Kr3 and Lr3 and the circuit is ready for the recording of a third dash of correct duration.

(3) *Third Dash of Correct Duration.* When a third dash of correct duration is received, the same sequence of operations will be repeated as previously described for the first and second dashes but now the brush N'1 will energise, through segment C4, relay Kr3 which locks up in series with the winding of relay Lr3 as soon as the signal has ceased, that is to say, when brush

arm N'1 leaves segment C4. Relay Lr3 then operates, closing its front contact 2.

When the brush arm N'1 has returned to its home position, the alarm bell circuit is established. At the same time relay Hr operates and locks up over its own contact, maintaining the alarm-bells operated.

It should be noticed that 12.4 seconds after the recording of the first dash of correct duration, the brush arm N2 makes contact with segment C13, thus energising relay Gr which operates. The back contact 2 of relay Gr breaks. This opens the feeding circuit of counting relays Lr1 to Lr3 and Kr1 to Kr3 and all these relays come to rest. The magnetic clutch M2 is no longer energised and the brush arm N2 returns to its home position by means of the resetting spring. The selector is now ready to record other alarm signals.

Should still another correct distress signal be received, the circuit operates as before, but the alarm bell circuit itself remains independently closed. To stop the alarm bells from ringing it is necessary to depress key RK which opens the alarm bell circuit and the locking circuit of Hr.

(4) *Dash of Too Short a Duration.* Any signal having a wavelength between 585 and 615 metres will energise relays Sr and Ar and consequently the magnetic clutch M1.

As the duration of the signal is below 3.5 seconds, the brush-arm N'1 cannot reach segment C4 before the termination of the signal. When the signal ceases, the brush arm N'1 returns to its home position.

As soon as the signal has ceased, relay Ar is deenergised and closes its back contact 2, causing relay Er to energise and lock up through its front contact 1. At the same time, the back contact 2 of relay Er breaks and opens the feeding circuit of magnetic clutch M1.

(5) *Dash of Too Long a Duration.* The rectified current generated by the incoming signal having energised relays Sr and Ar and the electromagnet M1, the time brushes N1 and N'1 start rotating as if a correct signal had been received.

After 3.5 seconds, contact arm N'1 reaches segment C4 and energises relay Kr (1, 2 or 3) which operates and through its front contact is placed in series with the winding of its associated

relay Lr (1, 2 or 3). Relay Lr does not operate as its winding is short-circuited. As we assume the dash to be of a too long duration, the brush N'1 will continue to rotate, and will pass on to segment C5, causing relay Gr to be energised and the following operation takes place:

- (a) The opening of the back contact 2 of relay Gr causes the feeding circuit of the counting relays to be broken, and so annuls the signals which may already be recorded. Relay Lr1 is deenergised and its contact 3 opens, thus deenergising the magnet-clutch M2. The timing brush N2 stops rotating and returns to its home position.
- (b) By the closing of the front contact 1 of relay Gr the latter locks itself.

When the signal ceases, the magnet clutch M1 is deenergised and the brushes N1 and N'1 return to their home position. As long as brush N1 is in contact with segment BC, the relay Er remains locked and prevents the recording of the signal during the passage of brush N'1 over segment C4.

Relay Er will release and bring back the magnetic clutch circuit to normal only when brush arm N1 has left segment BC and has returned to its home position. In this way, if another signal is received during the return to its home position of timing switch M1, this signal will be without effect.

(6) *Spurious Dashes of Correct Duration.* Due to the superimposing of several radio signals and also due to atmospheric interference, it may happen that relay Sr in the receiver remains energised during a duration of time corresponding exactly to the duration of a dash originated by a distress signal.

In this case, the selector will operate in a similar way as when a first dash of correct duration is received. Counting relays Kr1 and Lr1 will lock up and the time brush N2 will start rotating.

If the signals following are of too short a duration, the operation of the selector will be the same as in the case of a received signal of too short a duration.

Here again it should be noted that 12.4 seconds after the recording of the correct signal, the time brush N2 will come into contact with segment C13, annulling the previous recording. If the signals following are of too long a duration, the selector will operate as in the case of a received signal of too long a duration and the selector will be brought back to its normal position.

If a second dash of correct duration takes place during the time interval of 12.4 seconds following a first correct dash, it will be recorded as a second dash of correct duration.

In order that the selector may operate the alarm bells, it is necessary that a third spurious dash of correct duration be produced before the brush arm N2 reaches segment C13. The probability of such a happening is very remote indeed.

(7) *Distress Signals Superimposed on Other Signals.* Simultaneously with the distress signal, other signals may be received with the following result:

(1) The duration of the dashes may be lengthened in a proportion rather difficult to determine exactly. Practice has shown, however, that this lengthening in most cases is of the order of 0.5 second maximum.

(2) The intervals between consecutive dashes may be filled by spurious signals of short duration, even to the point of completely disappearing, thus preventing any accurate determination of the duration of intervals between the dashes.

Under these conditions, the received signal corresponds to:

- (a) Three dashes having a duration not exceeding 4.5 seconds each. In this case, the selector will work as explained above for a correct sequence of signal dashes. If a signal due to interference is received during the interval of time separating two consecutive dashes, the selector will function as for a dash of too short a duration.
- (b) Normal dashes mixed with dashes of too long a duration. In this case, the normal dashes are recorded. Too long a dash succeeding one or two correct dashes will annul the previous recording and the selector will start again to record new signals.

As has been previously stated, the "automatic distress signal" consists of twelve dashes sent out in one minute and, provided that the receiver can detect out of the twelve, three consecutive dashes of correct duration, the selector will record them and cause the alarm device to operate.

Results of Practical Tests

The type A.A.2.B. equipment as described above was submitted for approval to the General Post Office of Great Britain, which carried out the following trial tests:

- (a) The complete outfit was installed in a small build-

ing along one of the quais at Ramsgate, situated at the northern entrance of the Dover Straits. At this particular spot, the interference from numerous ships and coastal transmitting stations is exceedingly heavy.

- (b) The receiver was locally excited by an oscillator operating on a wavelength between 585 and 615 metres, and "distress signals" were keyed by a Weston transmitter. Eleven different combinations of signals, taking into consideration the different tolerances on the duration of the dashes and the intervals, were sent out. Each combination was repeated ten consecutive times. Under these conditions, there were no failures in the operation of the auto-alarm.

- (c) According to the Board of Trade's Statutory Rules and Orders, 1932, No. 897, the equipment when installed in an area of intense interference for a continuous period of six weeks, must not give more than two false calls in any week, while on the other hand, it must respond to 90 per cent of test calls.

For these tests, the receiver was connected to an antenna and the "distress signal" received consisted of twelve dashes of 4 seconds separated by intervals of one second, the transmission of the signals being made at random intervals.

During these tests, lasting for two months, there were only eight failures to respond to the test calls out of a total of 700, although the test conditions allowed 70 such failures.

Although the "distress signal" was transmitted only during certain periods, the equipment was permanently in service and was subjected to the action of atmospherics and signals other than alarm signals. Not more than the prescribed two false calls in any week were recorded during the testing period.

- (d) During the test, the equipment was placed in an oven as required by the Board of Trade Rules, and raised to a temperature of 113° F. for two hours on every third day for four weeks. The efficiency of the equipment was maintained during the operation of this test.

In addition to the foregoing, the equipment was also subjected to another severe test, which may be called the "bumping test." The apparatus was mounted on a platform which was capable of being rocked about, and of being dropped vertically through a distance of three inches every seven seconds. This rough treatment, continued for one hour a day for four weeks, did not affect the efficiency of the apparatus, or its ability to function satisfactorily during the actual periods of "bumping."

As a result of the above mentioned trial tests, the equipment was approved by the General Post Office of Great Britain for installation on board of all compulsorily fitted ships.

The 7-D Rotary Automatic Telephone System

By W. HATTON and J. KRUTHOF, e. i.

Bell Telephone Manufacturing Company

PART I

GENERAL FEATURES

THE continued and uninterrupted progress of the Rotary System will be acknowledged by those interested in the development of automatic telephony. It is a tribute to the merit of this system that exchanges which were installed during the difficult years of the war, are still in operation and daily fulfilling the needs of the telephone public with reliability and with many years of useful service before them. Today the Rotary System is installed in many of the principal cities of Europe: Oslo, Copenhagen, The Hague, Brussels, Antwerp, Liège, Paris, Zurich, Basle, Geneva, Madrid, Barcelona, Bucharest, Budapest, and even so far afield as Stamboul, Cairo, Shanghai, and Rio de Janeiro. In round figures, 1,621,000 lines are installed in 23 different countries and in 642 different exchanges.

The purpose of this article, however, is not to describe the Rotary System suitable for large towns, but to explain the problems encountered in the automatization of telephone areas of small communities.

The engineers of the Bell Telephone Manufacturing Company commenced the design of automatic equipment for small communities in 1925. One year later the first exchanges were installed. This type of equipment is termed the 7-D Rotary System, and there are now 77,500 lines installed and on order, involving approximately 300 exchanges.

The first 7-D Rotary equipment was of a relatively simple nature and only provided for automatic completion of local connections, whereas all outside connections were handled by an operator at the nearest toll exchange.

Present day requirements, however, are such that telephone exchange equipments for small communities must be capable of automatically completing connections over a wide area.

The largest rural area served by the 7-D Rotary System is situated in the neighbourhood of Zurich and comprises 50 offices with a total of 14,800 lines (Figs. 1 and 2). This area interworks on a full automatic basis with the 7-A Rotary multi-office area of the city of Zurich. The complete Zurich district, therefore, comprises approximately 66,000 subscribers' lines interconnected on a full automatic basis. Subscriber-to-subscriber dialling between the Basle and Zurich urban exchanges is already in operation, and in the near future the same service will be extended to the rural subscribers. When this is realised, over 100,000 lines of Rotary equipment installed in 124 different exchanges will have the facility of full automatic interconnection. The two most distant exchanges will be over 100 Km. apart, and the area covered will exceed 1,500 square kilometers.

Among other important 7-D Rotary areas completed, or in the course of construction, may be mentioned: Brussels, Antwerp, Basle, Geneva, Grosseto, Pisa, Sienna, and Haarlem (Figs. 3 to 13 inclusive).

In practice, automatic equipment can only be justified if the annual charges are less than those of manual equipment.

When studying automatic versus manual telephone service, it is evident that the first cost of the automatic equipment is not always the deciding factor. External plant, including cable, overhead lines, and buildings are part of the

whole telephone system just as much as the automatic equipment, and these items also contribute to the initial cost of providing automatic service. Annual expenditure for renewals and personnel, including both the maintenance and operating staff, must also be considered.

Similarly, the advantages and disadvantages of different automatic systems cannot be determined without careful investigation of all costs, and consideration of these factors will undoubtedly result in the choice of the 7-D Rotary System.

Application of the System

Outside the limits of most large cities there are suburban districts requiring rapid means of communication with the cities. The general interest of small communities is directed to the nearest city where business is transacted, produce marketed, and daily necessities obtained. Manufacturers frequently find it economical to locate their offices in the city and to find a site for their factories at some distance from the city where taxes and ground rents are lower.

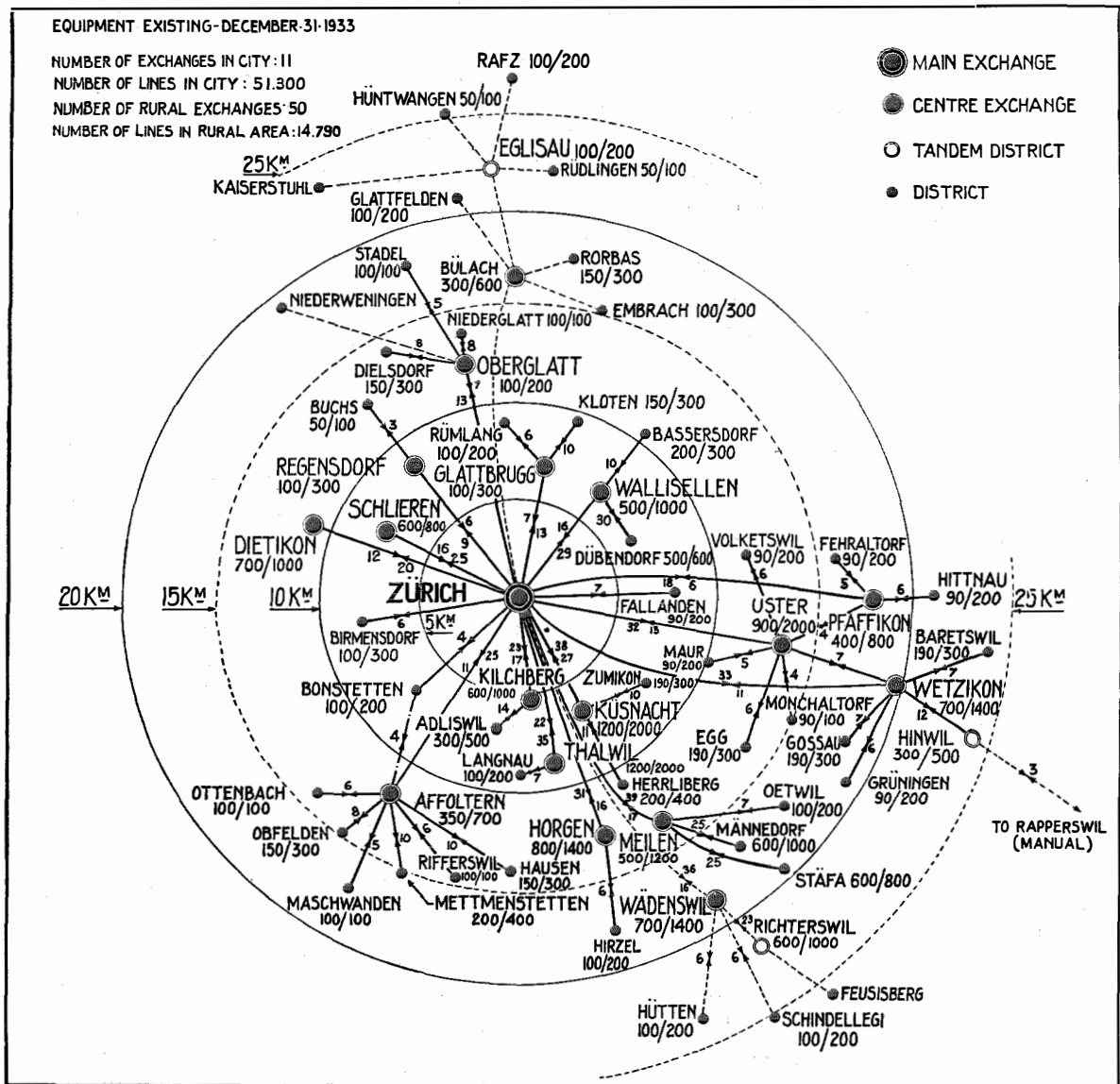
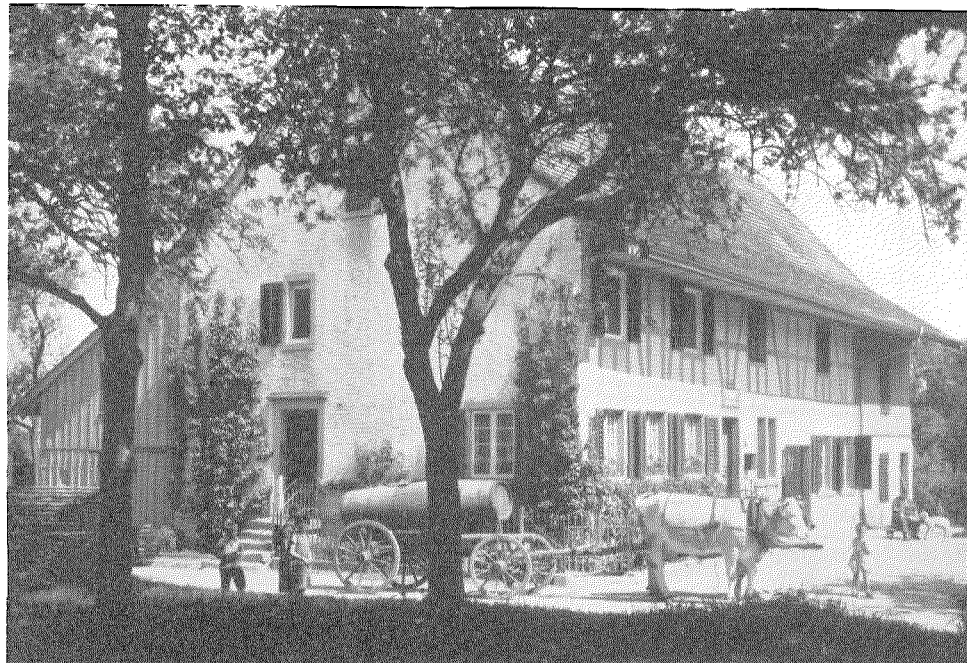

Fig. 1—Zurich Rural Area.



*Fig. 2—Oberglatt Centre Exchange—Zurich Rural Area—Switzerland—300 Lines Capacity.
(See Figs. 18 and 27).*

In many cases, this community of interest is not restricted to the city and its suburbs proper, but may include neighbouring villages and smaller towns over an area as large as 800 square kilometers.

Under these circumstances, it is natural that the majority of the telephone traffic is to and from the city; in fact, experience shows that these connections are usually between 80% and 90% of the total and rarely fall below 60%. It is evident that for telephone traffic of this character the type of equipment which restricts full automatic service to the small percentage of local connections and requires the assistance of an operator for all incoming and outgoing traffic, is neither suitable nor economical.

Where interworking with manual exchanges is wanted, there must of course be some kind of transition period for which the exact arrangements to be made will depend upon the amount of manual equipment and the date on which it can be replaced by automatic. During this

transition period, the rural automatic equipment does not require all features which are wanted when the whole area becomes automatic; for example, time and zone metering equipment can be omitted, but it is absolutely essential that the equipment be designed for the later introduction of full automatic network operation.

When designing the 7-D Rotary System, the requirements of many different countries were examined for complete network operation and then for temporary connections to manual exchanges. It is, therefore, possible to guarantee that units furnished for interworking with manual exchanges can be used with full satisfaction when the area becomes completely automatic.

The application of the 7-D Rotary System is not restricted to small rural and suburban exchanges only. It can also be used for city equipments with capacities up to 4,000 lines and the eventual possibility of building economical units up to 10,000 lines.

Advantages of 7-D Rotary System Automatic Service

It is well known that an efficient service creates a demand and, following the conversion from manual to automatic telephone service of any large city, the telephone users of the surrounding districts usually lose no time in requesting automatic equipment. From the subscribers' point of view, the advantages of automatic equipment are:

- (1) Day and night service,
- (2) Secrecy,
- (3) Rapidity,
- (4) Accuracy.

It is generally accepted that an operator makes errors up to 3%, and the more operators required to complete a connection, the more wrong connections there are likely to be. Rotary equipment is operating with 0.35% total machine errors.

Advantages of 7-D Rotary automatic equipment are:

- (1) Saving of operators,
- (2) Cheaper buildings,
- (3) More efficient use of external plant,
- (4) Increased revenue,
- (5) Lower maintenance costs,
- (6) Less clerical work.

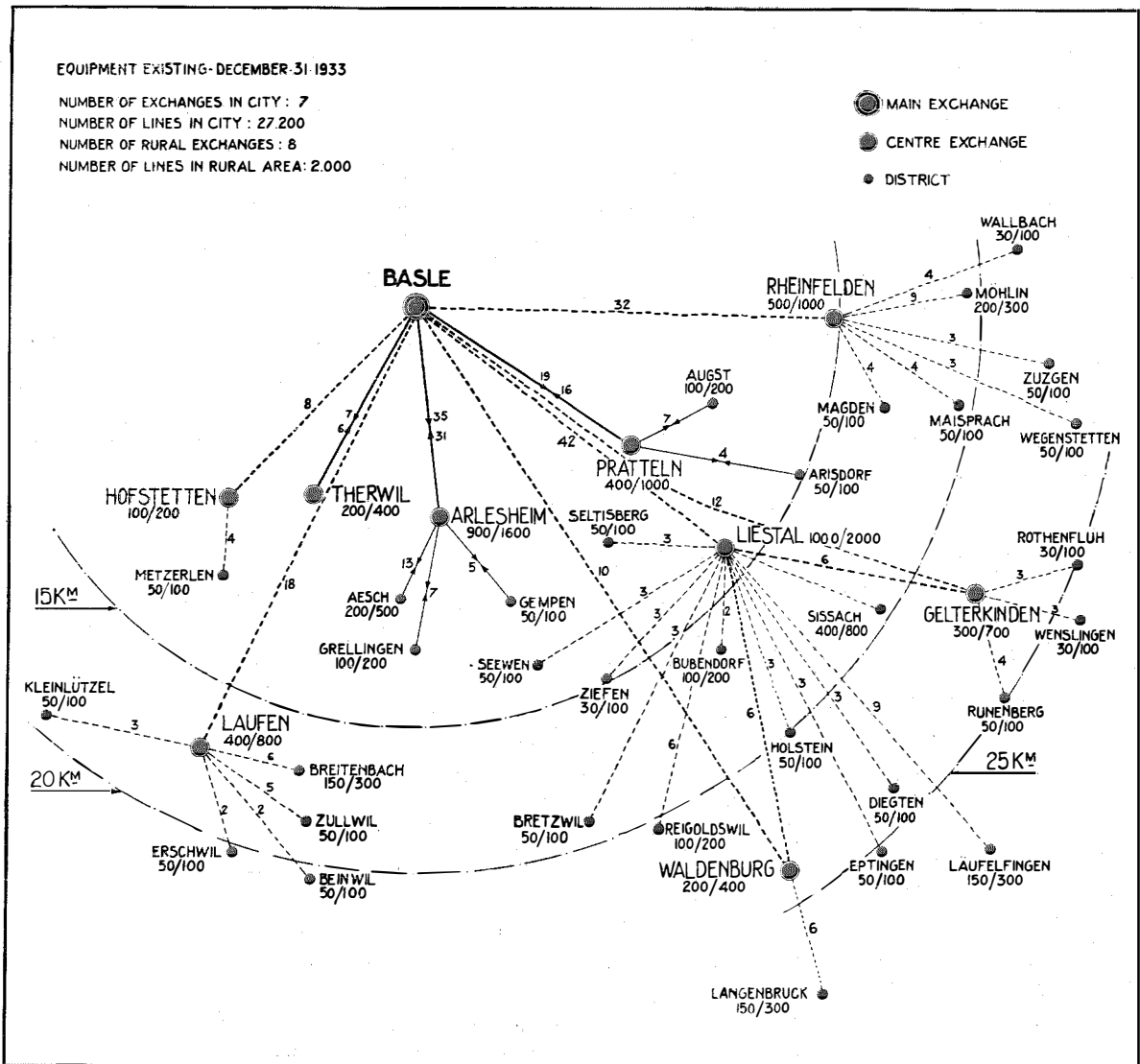

Fig. 3—Basle Rural Area.



Fig. 4—Waterloo Centre Exchange—Brussels Rural Area—1,000 Lines Capacity.

Due to the elimination of operators, no capital reserves are required for operators' pensions, and no expense is incurred for operators' sick leaves, holidays, and training. Rest rooms, dining rooms, dressing rooms, and other special accommodation usually provided in the larger exchanges may be dispensed with so that buildings of simple construction may be used for the exchange equipment. In case of small exchanges, suitable premises in most cases can be hired on a long lease from local authorities.

With automatic, direct junctions are not required between all exchanges and, compared with manual, more exchanges can be connected in tandem without degrading or slowing down the service. This feature permits junctions to be grouped together and increases their efficiency.

The reduction in the number of junction groups of necessity leads to fewer underground and aerial routes. Automatic disconnection eliminates loss of time which, with manual service, may average 10 seconds per connection.

With full automatic rural service, connections can be metered automatically on a time and distance basis. The maximum time variation permitted is 5 seconds whereas, when tickets have to be written and the connection is supervised by operators, the loss in revenue is considerable,

especially during the slack hours when one operator serves a number of positions. Further, the preparation of the subscribers' accounts is simplified as the sorting, recording, and filing of tickets is eliminated.

Remote control of routine testing of junctions and automatic equipment permits 7-D exchanges to be unattended, thereby reducing maintenance costs to the minimum.

Junction Layout

In urban areas it is common practice for a number of main central exchanges to be connected together with direct junctions, but in suburban and rural areas where distances are greater and junction groups are smaller, it is clearly not economical to provide junctions between each exchange and every other exchange in the network, or between a central exchange and every other exchange. In manually operated suburban and rural areas, direct junctions between exchanges are a necessity. These junctions are generally operated at very low efficiency and, moreover, represent heavy capital investment. One of the outstanding advantages of automatic equipment is that without unduly complicating the numbering scheme, or delaying the service, it permits simplification of the junction layout

and concentration of the junctions in large groups to be operated at high efficiency.

Small automatic exchanges are nowadays generally grouped in star formation but the 7-D Rotary System allows tie lines or direct junctions to be used where traffic conditions demand. These tie lines can be made to handle a considerable traffic load and their efficiency can be increased up to 75% or more, due to the "alternative trunking" feature of the 7-D register. A tie line

call tests, as a first choice, the direct junctions and, in case these are all engaged, the call will be automatically completed via the rural main exchange. The tie lines, therefore, can be deliberately kept down, whereas the number of junctions to the main exchange need hardly be increased as the amount of overflow traffic is extremely small when compared with the total traffic directed to the city.

The junctions between the centre exchanges

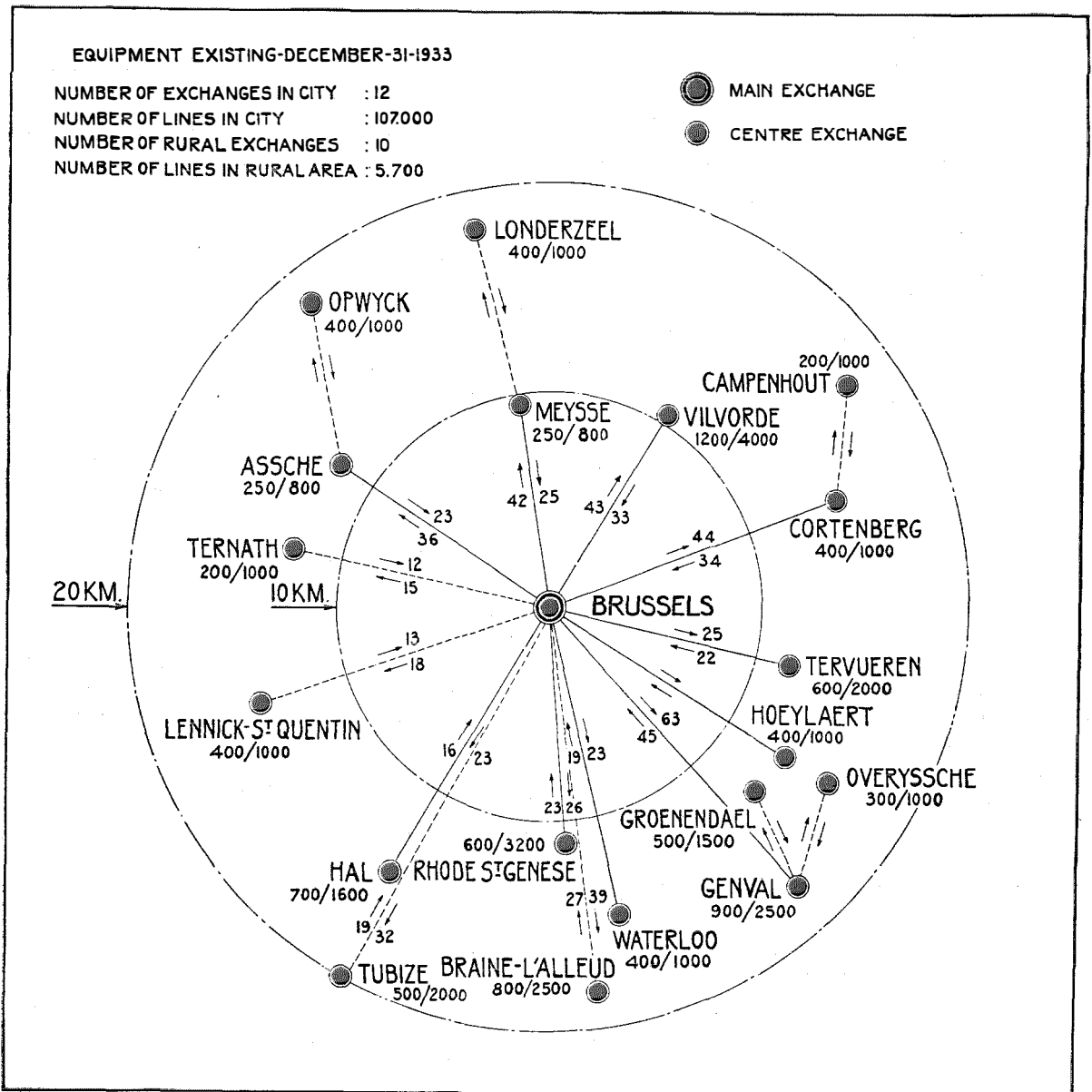

Fig. 5—Brussels Rural Area.

and the rural main exchange are usually of the single-way type and those between the districts and their parent centres or tandem districts of the both-way type. The one or two junctions between a relay satellite and its parent exchange are two-way.

Numbering

Three systems of numbering are available:

The first is termed "closed" numbering and includes the urban, suburban, and rural exchanges of the network in a uniform numbering

scheme without prefixes, all the exchanges in the area thus forming a homogeneous switching unit.

The second is a prefix system of numbering termed "open" numbering, each exchange being designated by a prefix consisting of a letter followed by two or three numerals. Where automatic connection between different networks is provided, three numerals are required, the first indicating the network, the second the sector, and the third the exchange in the sector. For local connections it is not necessary to dial the prefix.

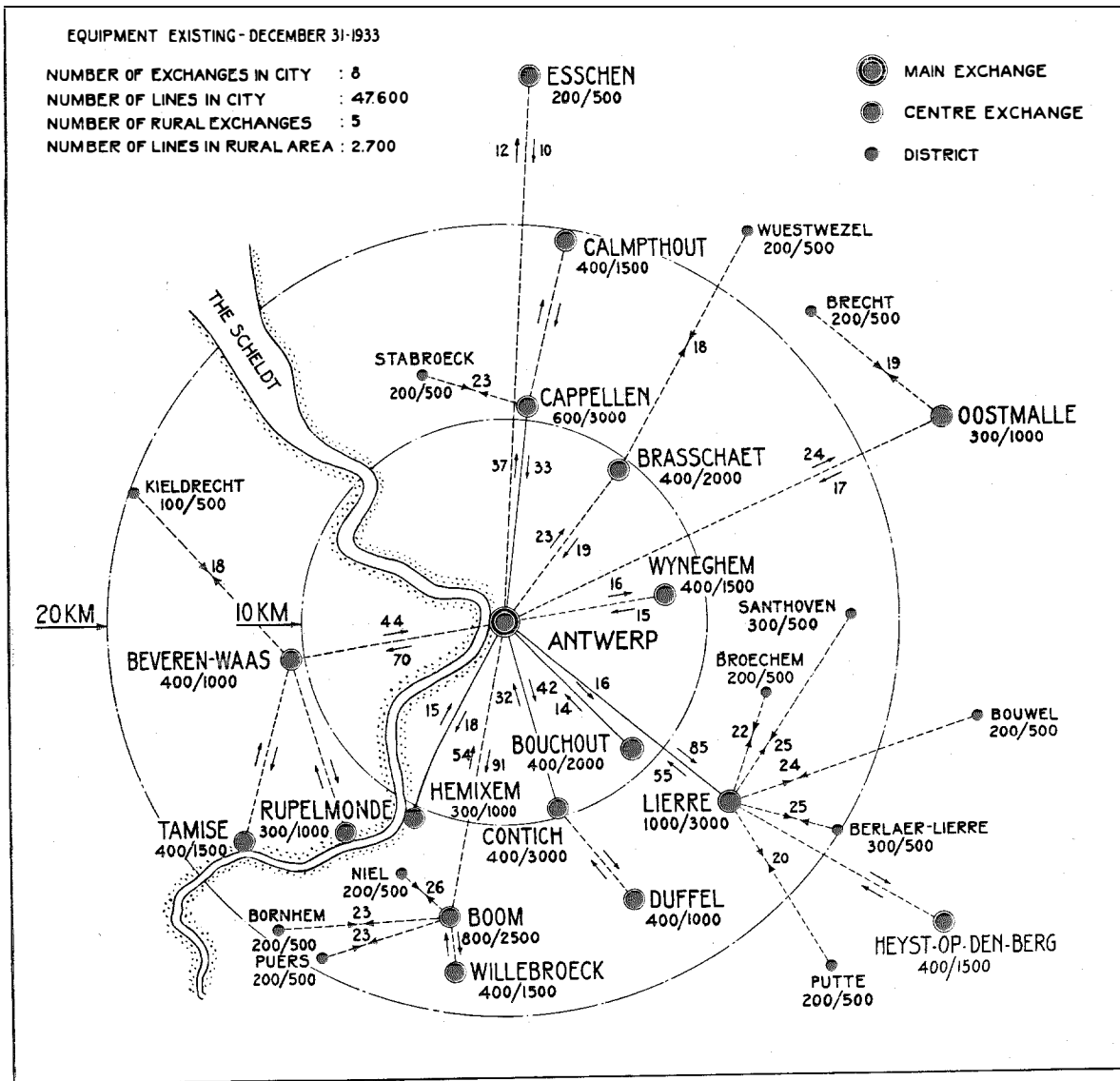

Fig. 6—Antwerp Rural Area.

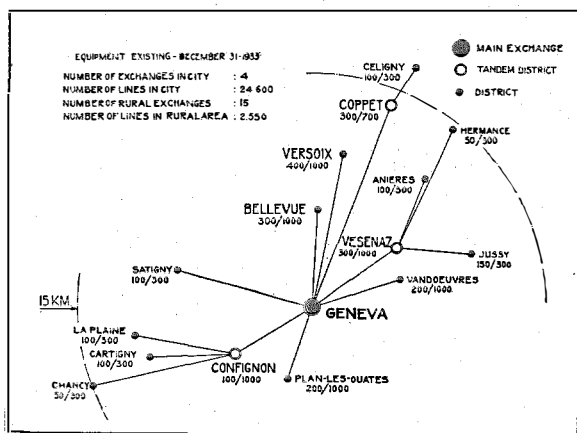

Fig. 7—Geneva Rural Area.

The third method is a mixture of open and closed numbering, the closed being retained for connections remaining within the network, and open for connections to other networks. All of these methods have their merits and the 7-D Rotary System can be adapted to any one of the three schemes. The table shown on Fig. 8 illustrates the dialling effort required, from which it can be seen that closed numbering is preferable for exchanges with a small percentage of local traffic, and open numbering for exchanges with a high percentage of local traffic.

As will be seen later, the register circuit of the 7-D Rotary System includes a simple translator by means of which it is possible to arrange for exchange capacities of 200 or 2,000 lines without loss of numbers and without separate groups of junctions for each 100 or 1,000 lines as the case may be. On a decimal basis, a 200 line unit would require 1,000 numbers, and a 2,000 line unit 10,000 numbers. This feature is valuable when it is necessary to include the numbering of a rural or suburban area in the existing urban network.

Under these circumstances, automatic systems which do not have the advantage of the translation feature included in the 7-D register circuit, would employ mixed numbering or, possibly, change 5-digit numbers into 6-digit numbers.

Metering

The metering or registration of the connections is particularly interesting because, with the elimination of the operator, it follows that such

registrations must be made on the subscriber's service meter; and that, to account for both distance and time, the meter must be operated a number of times per connection. It is obvious that no record of such individual connection can be retained, as was the case where all connections other than local passed via an operator, and were "ticketed." Administrations have therefore no means of checking subscribers' complaints and, for this reason, hesitate in some cases to dispense with the operator.

Another difficulty arises with the introduction of time and distance metering, viz., when a certain number of local calls are given free of charge, and all outgoing calls are charged on a time and distance basis. A third case is when

CLOSED 5-DIGIT NUMBERING				
Any subscriber dials on calls to:				
95% local + rural		95	5	= 475 Digits.
5% special services		5	2	= 10 "
Total:				485 Digits.
Average:				4.85 Digits.
OPEN NUMBERING				
A. Subscriber connected to 3-digit exchange dials on calls to:				
Local (3 digits)	20	60	70	210
Rural (1+2+3½ digits)	15	95	10	65
City (1+2+5 digits)	60	480	15	120
Special services (1+2 digits)	5	15	5	15
Total:		650		410
Average:		6.5		4.1
B. Subscriber connected to 4-digit exchange dials on calls to:				
Local (4 digits)	20	80	70	280
Rural (1+2+3½ digits)	15	95	10	65
City (1+2+5 digits)	60	480	15	120
Special services (1+2 digits)	5	15	5	15
Total:		670		480
Average:		6.7		4.8
C. Subscriber connected to 5-digit city exchange dials on calls to:				
Local (5 digits)			85	425
Rural (1+2+3½ digits)			10	65
Special services (1+2 digits)			5	15
Total:				505
Average:				5.1

Fig. 8—Comparison Between Closed and Open Numbering.

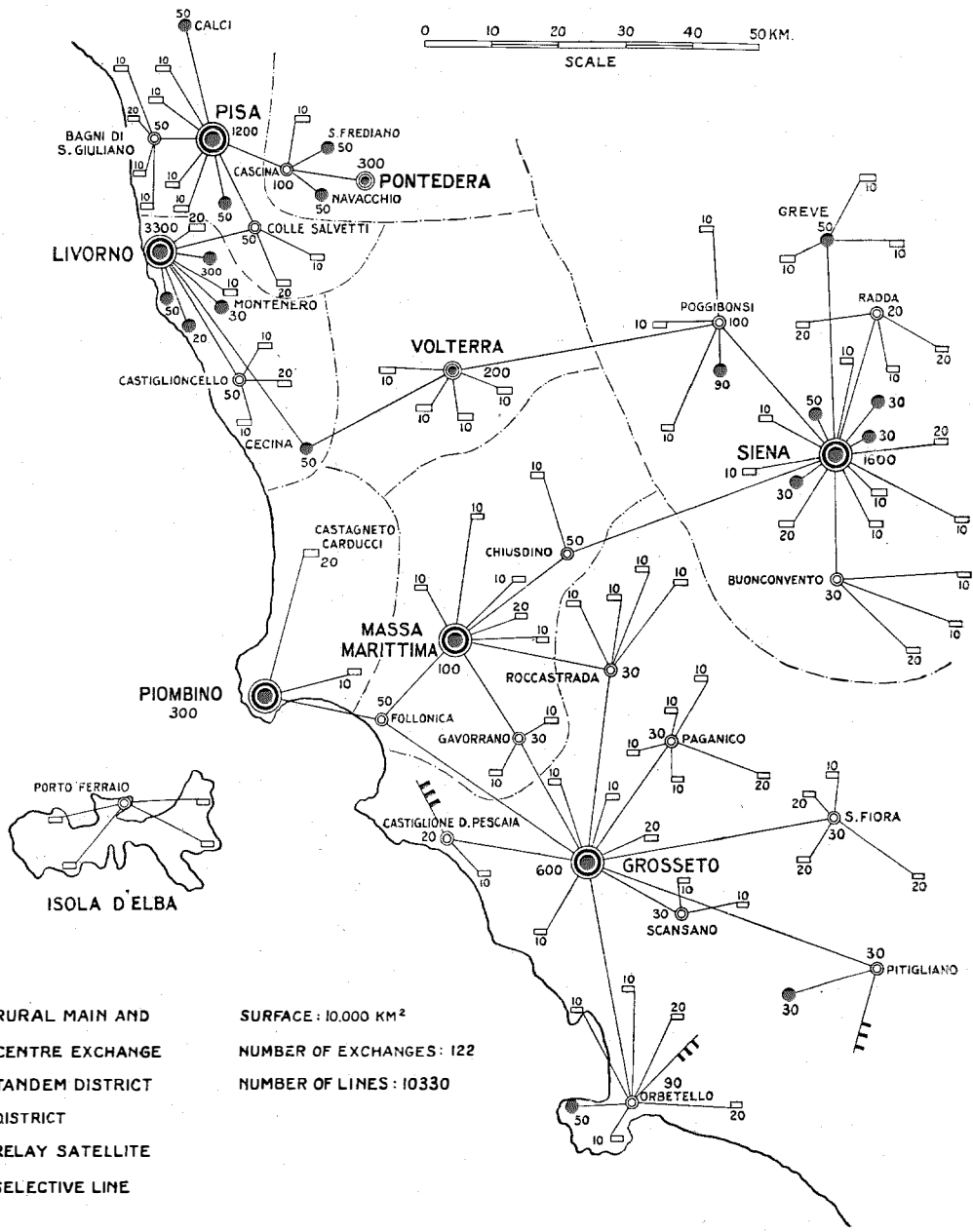

Fig. 9—Tuscany Rural Area—Italy.

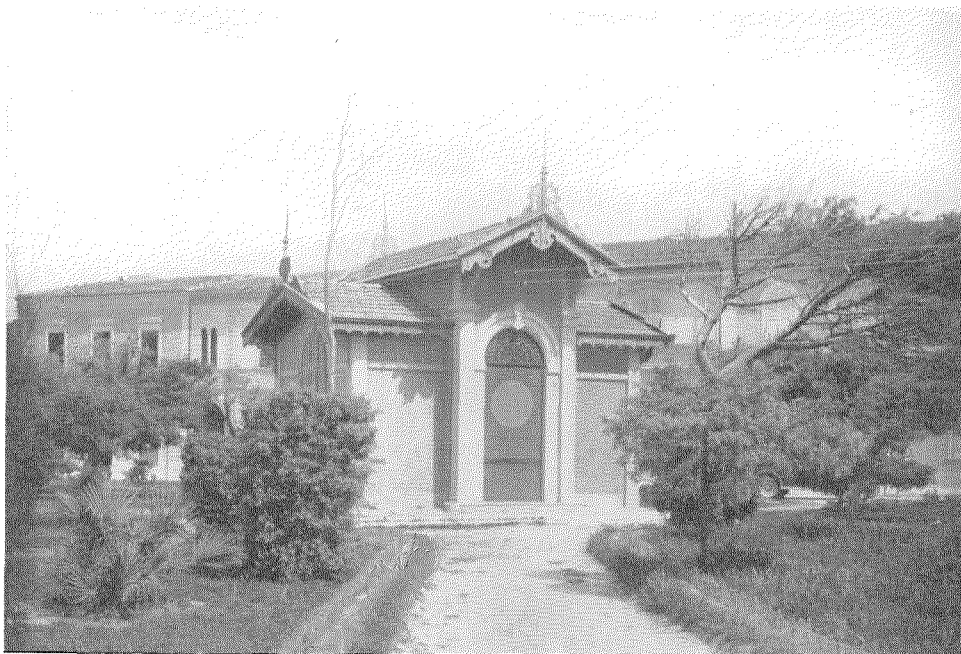

Fig. 10—Marina di Pisa District Exchange—Pisa Rural Area—Italy—500 Lines Capacity.

the fee for outgoing connections is not a multiple of the fee for local connections, e.g., a local call might be 25 centimes, time unlimited, and an outgoing call 70 centimes for each period of three minutes.

The first difficulty can be overcome by installing at the subscribers' premises, meters which are operated over the line, either during or after conversation, from the time and distance metering apparatus in the exchange, and which indicate to the subscriber the amount spent on each connection. Such meters are particularly useful in hotels where it is necessary to debit the cost of the connection to the hotel guest. In the second case, two service meters can be installed per line, the first indicating the total number of local connections, and the second the number of units spent on outgoing connections. The third case can be solved in the same manner.

A scale of payment with a unit fee for local connections and a multiple of this unit for outgoing connections is, however, clearly the correct solution. The calculation of a unit which will prove satisfactory to the subscribers and at the same

time will not involve any loss of revenue to Administrations can sometimes be simplified by taking into account the length of time permitted on outgoing connections. Although three minutes is the general length of time at present in force, there is no reason why it should not be three and a half, or four minutes. A graduated scale decreasing with each successive period of three minutes is also possible without unduly complicating the time and zone metering apparatus.

Another point is that the reduced rate usually given during certain hours of the day must also be a multiple of the unit fee. Despite these apparent drawbacks, the public invariably favours the installation of full automatic equipment, and the increase in the number of new subscribers following its introduction proves the appreciation of a twenty-four hour no-delay service. Encouraged by these results, Administrations are now planning national full automatic service with subscriber-to-subscriber dialling, with time and distance metering on both short and long haul toll connections.

As one example of how time and zone metering

can be applied, local calls may be metered once, duration unlimited, outgoing calls may be metered 2, 3, 5, 7, or 10 times for each three minutes. The duration of other than local connections may be limited to a maximum of 6, 9 or 12 minutes and, 10 seconds before the expiration of this time, a warning tone is given indicating the approach of the time limit.

The repeated metering is made dependent on the air line distance separating the two exchanges. For this purpose, metering control circuits in the exchange where the connection is originated take a record of the first two or the first

three digits of the dialled number. By this means the identity of the distant exchange and, therefore, the class of metering are determined. One example of the application of this method of time and distance metering is as follows: Connections remaining within a radius of 5 kilometres, defined as the "office area", are metered once and are unlimited in duration; connections outside the office area, and within a radius of 10 kilometres are metered twice; between 10 and 20 kilometres, three times; between 20 and 30 kilometres, five times; between 30 and 50 kilometres, seven times; and between 50 and 100 kilometres, ten

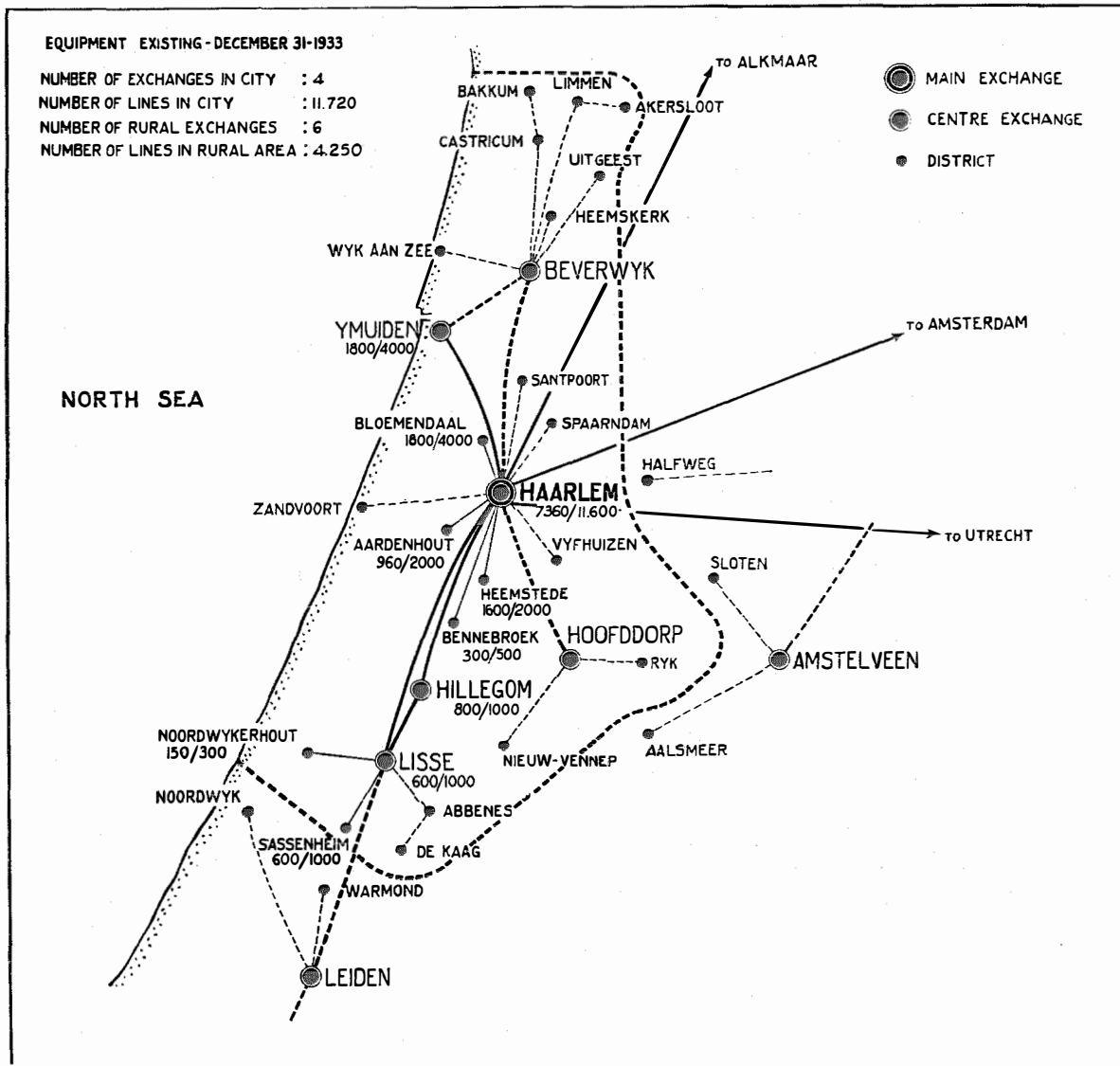

Fig. 11—Haarlem Rural Area.



Fig. 12—Ymuiden Centre Exchange—Haarlem Rural Area—Holland—4,000 Lines Capacity.



Fig. 13—Brondby Vester District Exchange—Denmark—600 Lines Capacity.

times. All connections outside the office area are metered at the beginning of each three-minute period.

The 7-D Rotary System is arranged to give 15 different classes of metering.

Combination of Single Motion Switch, Common Control Circuit and Register Circuit

These three elements form the basis of the 7-D Rotary System. The single motion switch is the well known power driven finder (Fig. 14), extensively used in the 7-A Rotary System. It functions both as finder and selector in the 7-D system; and, as selector, an associated common control circuit receives the impulses forwarded from the register (Fig. 15) and positions the finder on the marking principle.

The register circuits which are located in the centre exchanges receive the dial impulses from the centre and district exchange subscribers. The register circuit determines the routing of the connection, controls the selection, and decides the metering. Full advantage of the single motion switch and the possibilities it offers of breaking away from the limitations of the 100 point two-

motion selector with its rigid arrangement of 10 levels of 10 trunks, could not be achieved without the register. The combination of single motion switch with the register controlling the selectors, permits junction working with full availability.

With a single motion switch the number of outlets per group is not limited to 10 and the number of directions or levels can also be varied as required. This is a valuable feature in rural and suburban networks.

As a typical example of the flexibility afforded by this scheme, one stage of selection can reach say 10 directions each with 6 outlets, and 2 directions each with 20 outlets.

The register, after having sent forward impulses for selection, waits for a signal to indicate the completion of the selection. Whilst the register is waiting, the hunting switch rotates until a free outlet is found.

This feature removes the limitation on the size of junction groups imposed when hunting is restricted to the time between two digits. Further, calls which do not immediately find a free outlet are not lost, but merely delayed because, if a free outlet is not found the first

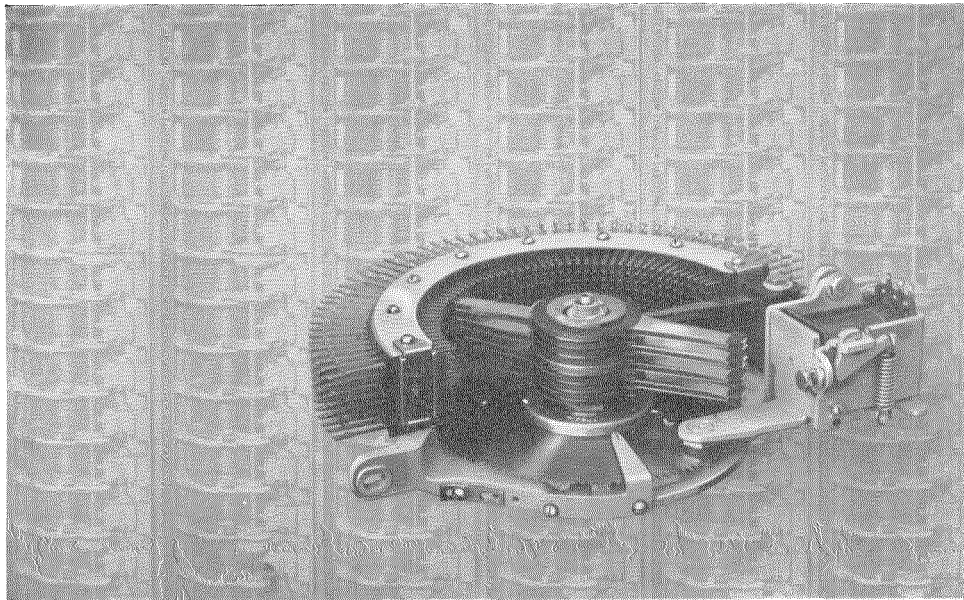

Fig. 14—Finder.

time, the switch hunts until one is found, i.e., continuous hunting.

With the 7-D system, therefore, the junctions can be worked at a more favourable probability of delay, usually 5%, without affecting the quality of the service.

Compared with other systems in which the size of junction groups is limited by the interdigital time, the 7-D allows a saving of 10 to 20% on the cost of the junction plant.

Further, considerable traffic overloads can be carried without serious reaction on the service.

The impulses are received in the registers and in the control circuits on marker switches illustrated in Fig. 16.

Fig. 17 shows the well known flat type relay, which is used throughout the 7-D Rotary System.

Finder

The power driven finder comprises two main parts: the arc containing the terminals to which the lines or junctions are connected, and the set of rotary brushes for wiping over these terminals. (Fig. 14).

The arc is mounted on a solid die-cast frame of aluminium alloy and comprises 100 sets of terminals each with two soldering points. The point nearest the frame serves for the connection of the multiple ribbon cable, the second point for the switchboard cables.

The number of terminals per set may exceed three and, normally, amounts to four or five,

which results in a simplification of the circuits and the elimination of marginal relay conditions.

By the operation of the single power magnet, the flexible gear rigidly mounted on the brush carriage, meshes with the gear of a permanently rotating shaft which is driven by a common motor.

The power driven finder rotates at a normal speed of 45 terminals per second. A complete revolution therefore takes approximately two seconds only. It moves smoothly and without any shocks or vibrations. The contact pressure of the brushes is minimum 40 grams.

The finder has only one adjustment, i.e., the air-gap of the electromagnet.

For use in Rural Automatic Exchanges, the power driven single motion switch has the following advantages:

- (a) Simple type of switch requiring little maintenance,
- (b) Single power magnet,
- (c) Smooth drive,
- (d) Number of brushes may exceed three,
- (e) The same type of switch for line finder and selector,
- (f) The number of directions is not limited to 10,
- (g) The number of outlets per direction is not limited to 10,
- (h) Overflow between directions can be introduced without any special arrangement,
- (i) Flexibility in the arrangement of P.B.X. facilities.

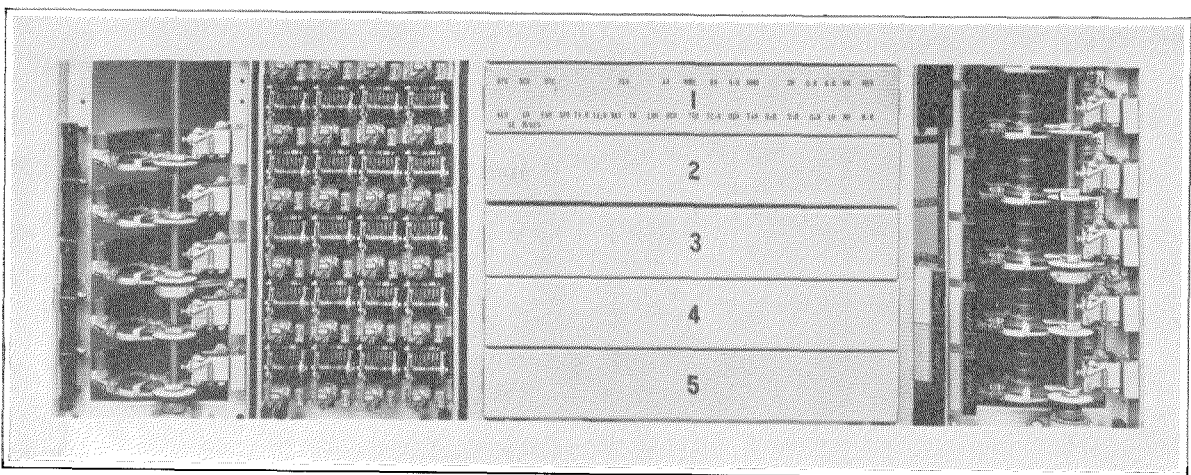

Fig. 15—Five Complete 7-D Register Circuits—Actual Dimensions 1,560 by 500 mm.

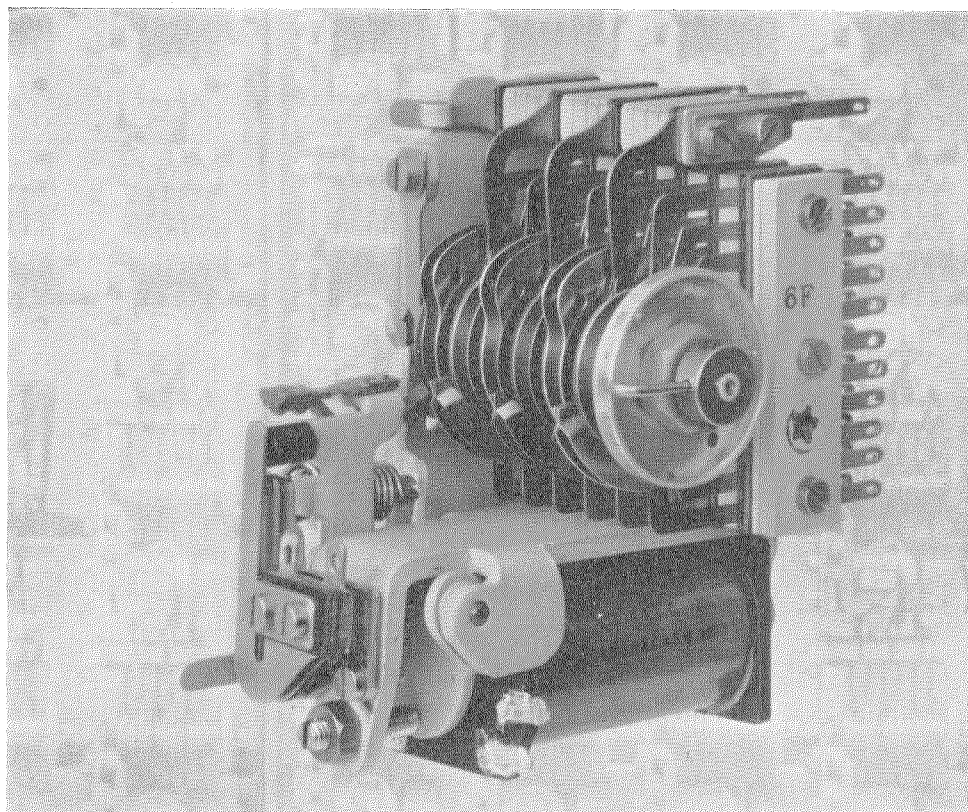

Fig. 16—Marker.

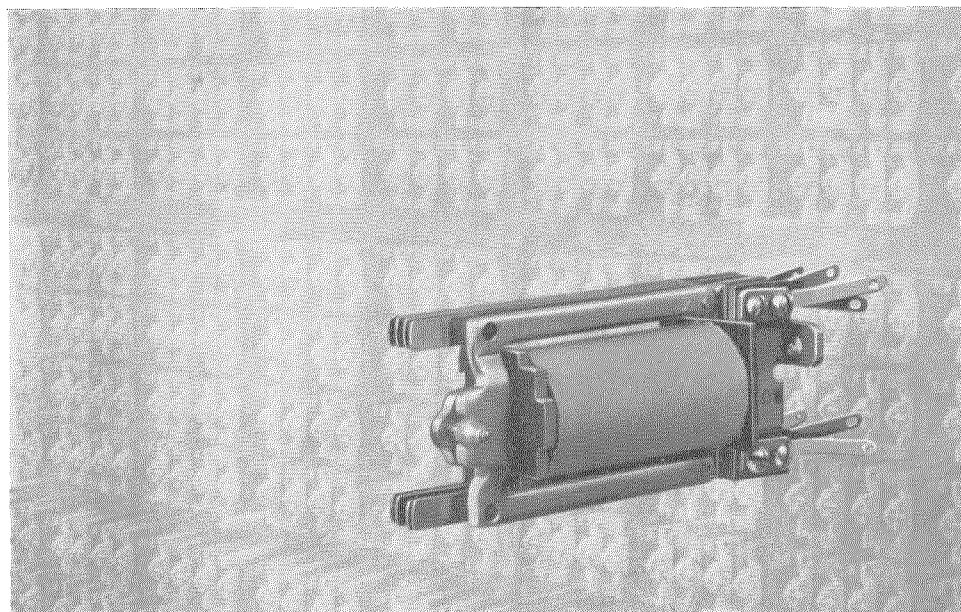

Fig. 17—Relay.

PART II

TYPES AND CAPACITIES OF EXCHANGES

CENTRE EXCHANGE**Switching Arrangement**

Reference to Fig. 18 shows that a centre exchange carries traffic not only to and from its own subscribers, but also to and from the subscribers of the associated district exchanges. Therefore, the amount of equipment and the switching arrangements of a centre exchange depend, firstly on the capacity of the centre exchange area and, secondly, on the capacity and number of district exchanges served therefrom.

The simplest form of switching arrangement is shown in Fig. 18. Relay groups containing supervisory relays feeding both calling and called parties, and time and zone metering switches, link together two 100 point finders, one of which functions as a line finder "LF" and the other as first group switch "IGS". Two groups of links are shown: one of six, and one of nine, carrying traffic originated by the 100 centre exchange subscribers, and the subscribers of the three district exchanges which are connected by 21 both-way junctions. Seven finders, with two control circuits "CC", function as final switches "FS".

The junctions between centre exchange and rural main may be either both-way or one-way. The figure shows a useful arrangement of seven

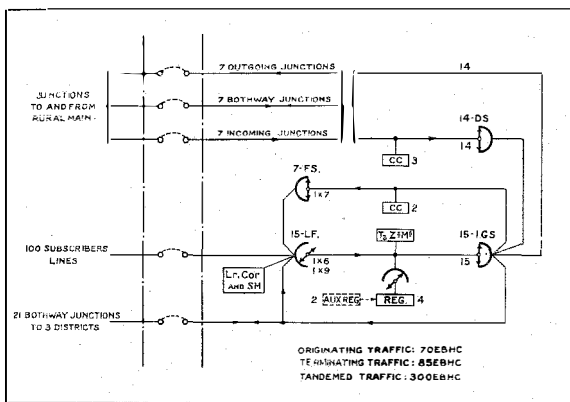

Fig. 18—Typical Junction Diagram—100 Line Centre Exchange.

outgoing, seven incoming, and seven both-way junctions. A group of 4 registers completes the equipment.

Fig. 19 shows the switching arrangement of a 900 line centre exchange. In this design, first and second line finders are used and 63 first line finders, in nine groups of seven, collect the traffic originated by the 900 centre exchange subscribers. Forty-two link circuits comprising: 2nd line finders, relay groups, and first group switches carry the traffic originated by the centre exchange subscribers and the three district exchanges. The first group switch gives access to 14 different directions, namely:

- 9 Groups of final switches,
- 3 District exchanges,
- Rural main,
- False call circuits.

The number of outlets per direction varies between 5 and 31. The facility of connecting more than 10 directions to the arcs of the first group switches enables the second group switches "IGS" (shown in dotted lines) to be omitted. The traffic to and from rural main is large enough to justify one-way junctions in each direction, and 35 incoming junctions terminate on switches associated with 7 control circuits. These are termed direction switches "DS". Traffic to rural main demands 31 junctions and the district exchange traffic demands 25 both-way junctions.

The centre exchange terminating traffic is carried by 7 final switches per group of 100 lines making 63 in total, associated with 9 control circuits. The switching scheme is completed by 9 local register circuits and two auxiliary registers used for automatic long distance connections.

Fig. 20 shows a switching arrangement for larger capacities of the order of 10,000 lines. An exchange of this size comprises first line finders, link and register circuits, third group selectors, and final selectors.

Each group of 100 subscribers lines is provided with 8 line finders. The traffic originated by the 10,000 subscribers divides into two distinct directions, the first being local traffic, i.e., towards

subscribers of the same exchange and to subscribers of surrounding rural exchanges, and the second being no delay toll traffic (C.L.R.) which is handled over the toll board. In this example approximately 30% of the originated traffic is "no delay" toll traffic.

A calling subscriber removing the receiver is connected in the well known manner over a first line finder and a second line finder to a free local register. If the call is local or to a neighbouring exchange, it passes over the first group selector IGS. If it is a "no delay" toll call, the calling subscriber is transferred from the second line finder IILF to a free CLR finder CLRF, and the second line finder with its associated first group selector is released.

It will be seen that this arrangement avoids carrying all the originated traffic over the first group selectors and, therefore, reduces the total number of switches required. In addition, the circuits associated with the CLR finders can be designed to include the special features required on toll connections such as: high efficiency talking bridges, through supervision and ring-back without complicating all the local link circuits.

The traffic which passes over the first group selectors divides in three parts: the first, traffic towards subscribers of the same exchange; the second, traffic to special services; and the third, traffic to other rural centres. Twenty terminals

of the first group selector arc are connected to the special service and rural second group selectors. The remaining 80 outlets are divided into 10 groups of 8 connected to the 10 groups of local IIGS. An ingenious arrangement of overflow trunking permits traffic destined for a given 1,000 line group to be routed over IIGS of another group, should all outlets leading to its own group be found engaged by the IGS. In effect, this arrangement gives 16 outlets per group of 2,000 lines instead of 8 per 1,000 lines.

The junction diagram shows 170 circuits, which are associated with the common group of 60 register circuits, for handling inward toll traffic. The operator dials the number of the wanted party and the connection is established over the same third group selector and final selectors as used for local connections. Full toll facilities, including break-down, offering and re-ring are given and the special relay groups required are located in the toll first group selector circuit. Should key-sending be required, the local registers can be designed to accept both dial impulses and keyset combinations. For a large exchange of this type, each first line finder group includes a special finder FCF which identifies faulty lines and signals the subscriber's number to the wire chief. When a faulty line is seized by a false call finder FCF, the regular line finders and registers are released. The 100 FCF

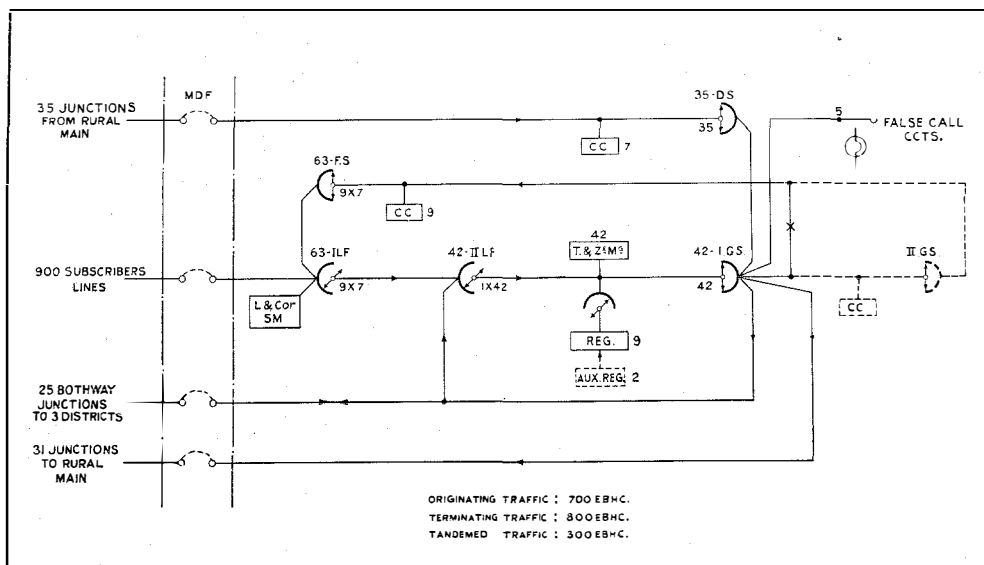

Fig. 19—Junction Diagram—Arlesheim 900 Line Centre Exchange—Basle Rural Area—Switzerland. (See Fig. 28).

finders are connected over an intermediate finder to the test bay, and when a fault is signalled the wire chief can test the line over these circuits without plugging in at the main frame.

Fig. 21 shows the switching scheme of a typical Rural Main exchange. Three groups of direction switches DS carry the traffic between the different rural sectors, the city and the rural exchanges, and the inward and outward toll traffic.

Switchrack and Drive

In the design of the equipment, great attention has been paid to the fact that in the majority of cases the installations will not be housed in buildings specially arranged for the purpose. This is evident from the various photographs of rural exchange buildings included in this article. As a result, the equipment methods must fulfill a great variety of requirements as regards ceiling height and shape of the switchroom.

Further, the weight of each unit has been reduced to facilitate handling and installation without special appliances, it being recognised that the same degree of skill cannot always be obtained as on the installation of telephone plants in cities.

The automatic centre exchange equipment is mounted on vertical bays which are placed on robust switchracks. Each switchrack comprises a ground channel mounting horizontal shafting with bearings and gears driven by one or more electric motors.

The height of the racks varies in accordance with the ceiling height of the switchroom. The length of the racks is chosen so as to use the available floor space to the best advantage.

Standard racks are available in two sizes as follows:

- (A) Minimum ceiling height 3 meters.
Height of switchrack 2.6 m.
Height of bay 2.2 m.
A finder bay of this height mounts 25 machines.
- (B) Minimum ceiling height 3.9 m.
Height of switchrack 3.5 m.
Height of bay 3.1 m.
A finder bay of this height mounts 36 machines.

The upper part of the switchracks is supported

by iron verticals and carries the cabling between the various bays, the cross connecting frames and the main frame, also the power and tone leads with the necessary accessories. Sufficient working space should be left between the top of the racks and the ceiling.

The racks may all be placed facing one direction or back to back in pairs, as most convenient to the customer.

Each motor is provided with a reduction worm gear and, if necessary, with special fixing means so as to allow quick replacement. The motors may be battery driven and are in some instances combined with the ringing and tone generators. For larger exchanges, Duplex motors are supplied so as to economise on the current consumption of the exchange. The outside supply of Duplex motors is controlled by a special panel which changes from a-c. to d-c. supply in case of failure.

For the smaller type exchanges, the motor does not run continuously but is only started when necessary.

The size of the motor is chosen in accordance with the required power output and varies from 1/32 to 1/8 H.P.

The switchracks are further adapted to mount lighting and heating accessories, which equipment is only included at request. The heating elements are controlled by a contact hydrometer which operates when the 80% moisture limit is reached.

The cabling side of the switchrack may be protected by screens, which are mounted on brackets forming part of the switchracks and which may easily be removed.

Complete shielding of the bays as in the 7-A.2 Rotary System is not necessary for rural automatic equipment which is unattended and not likely to be damaged by careless maintenance.

Equipment

The automatic centre exchange equipment is mounted on vertical bays which are in accordance with the type of apparatus accommodated, distinguished as relay bays, marker bays and finder bays.

The grouping of the equipment and the dimensions of the bay depend on the size of the exchange, the available ceiling height, and the prevailing traffic conditions.

Fig. 22 shows a rack on which 3 units are

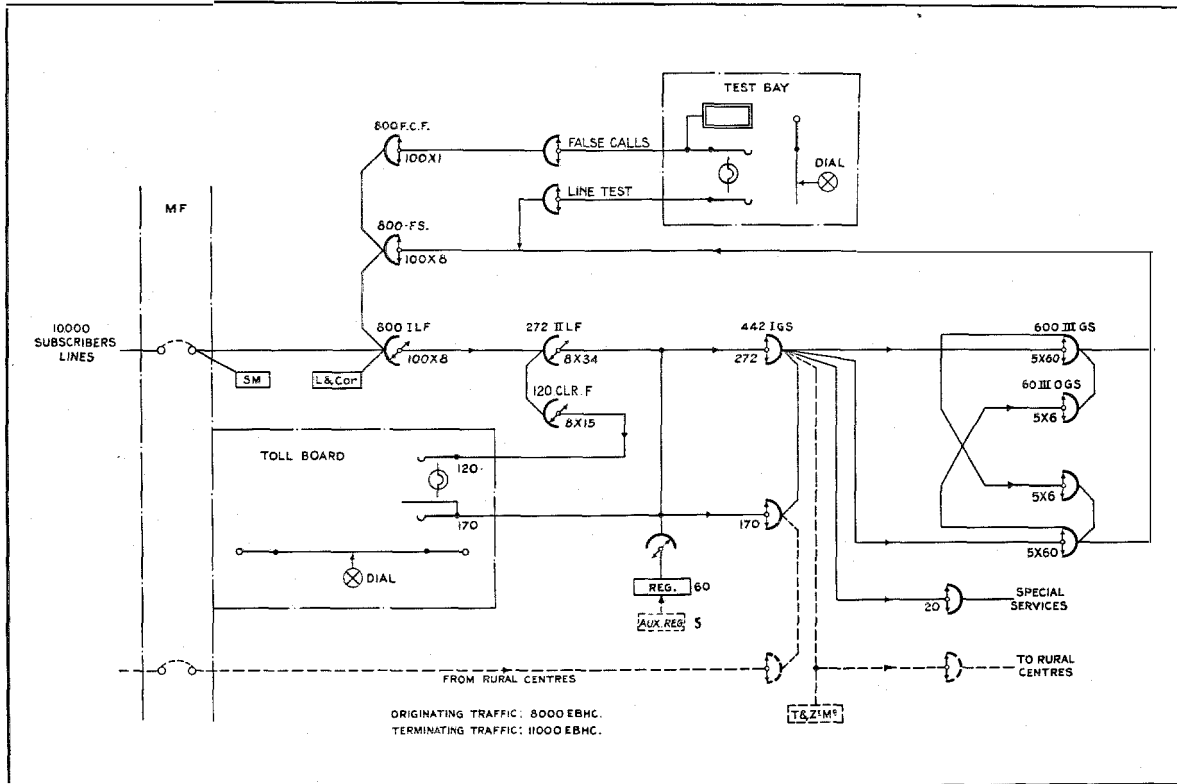

Fig. 20—Typical Junction Diagram—10,000 Line Centre Exchange.

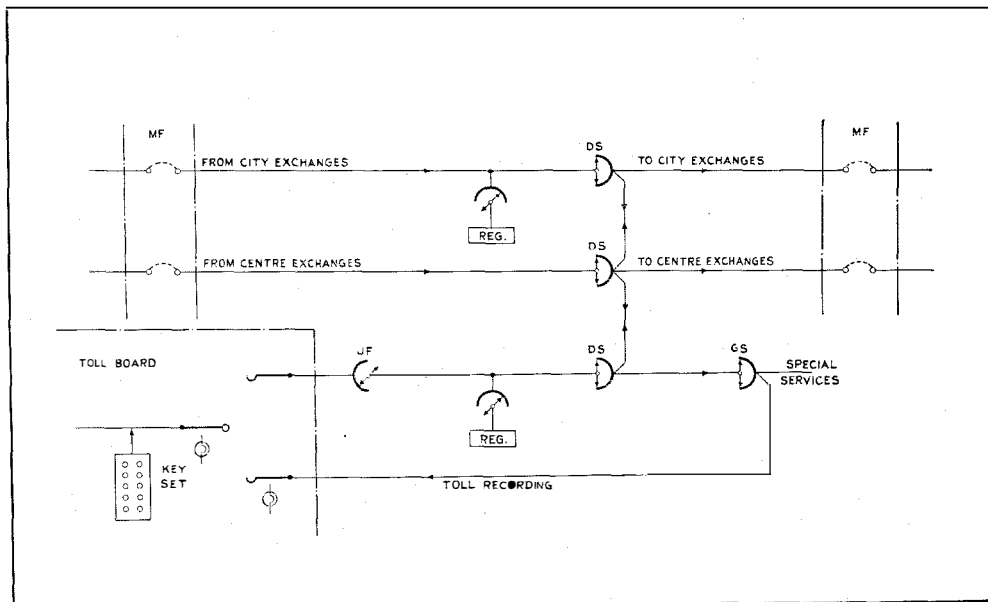

Fig. 21—Typical Junction Diagram—Rural Main Exchange.

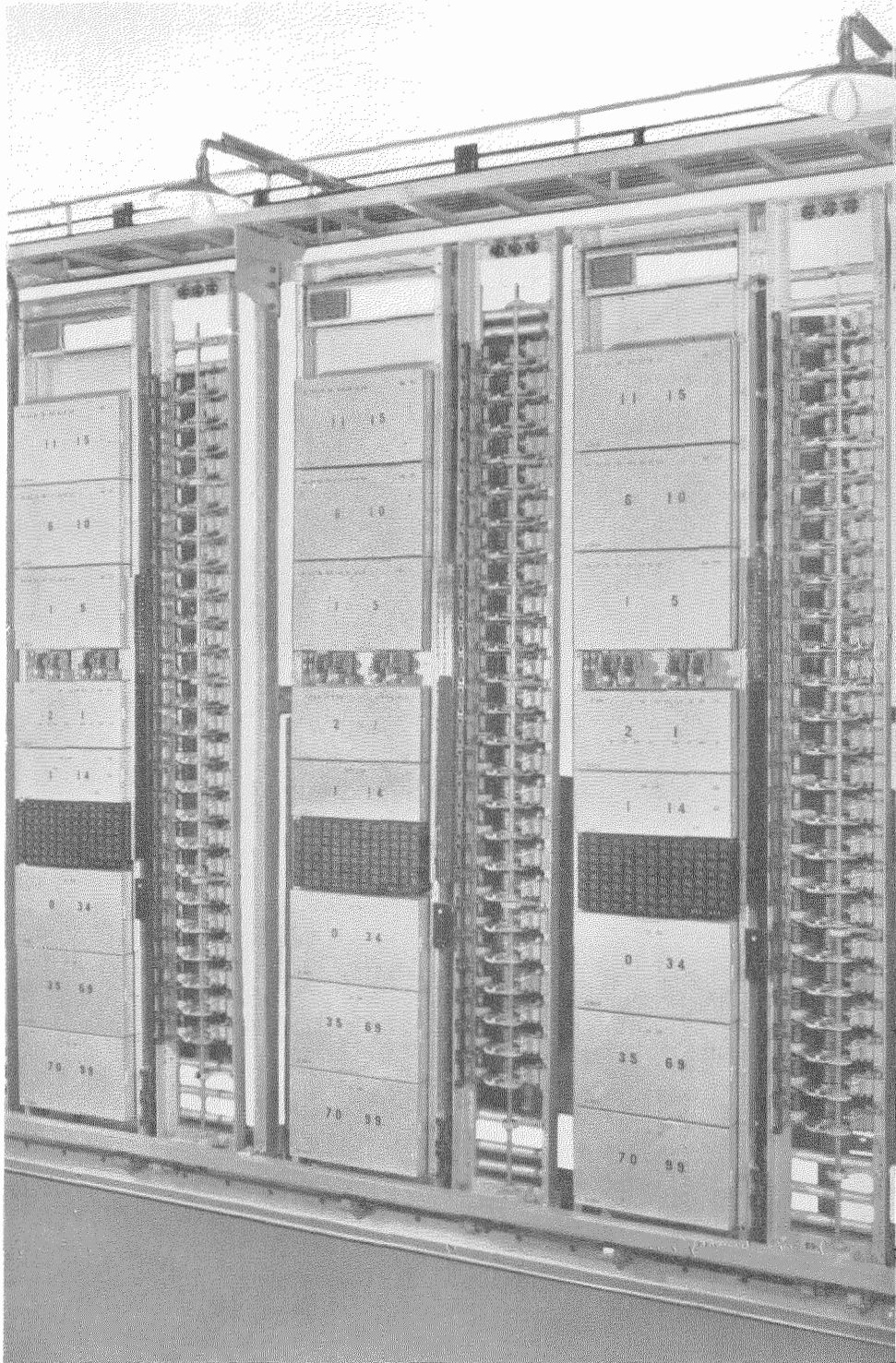

Fig. 22—Subscriber Line, 1st Line Finder and Final Units.

placed, each of which mounts the following equipment:

- 100 subscribers' line circuits,
- 100 service meters,
- 11 (capacity 14) 1st line finders and associated relay equipment,
- 13 (capacity 15) final selectors of the finder type including associated circuit equipment,
- 2 final control circuits.

The 1st line finders and finals serving 100 lines are mounted in straight multiple on one finder bay.

A layout for similar equipment, but suitable for a lower calling rate, is shown in Fig. 23. Here, two relay bays and two finder bays mount in total:

- 300 subscribers' line circuits,
- 30 battery feeding circuits,
- 20 adapter circuits for 2-party lines,
- 3x8 complete 1st line finder circuits,
- 3x8 complete final selector circuits,
- 3 control circuits,
- 1 dead line circuit.

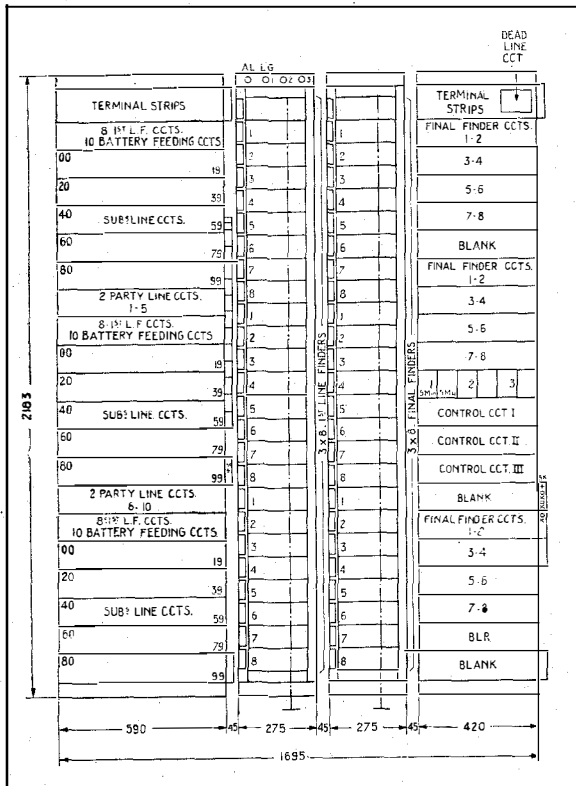

Fig. 23—Subscriber Line, 1st Line Finder and Final Unit—300 Lines Capacity.

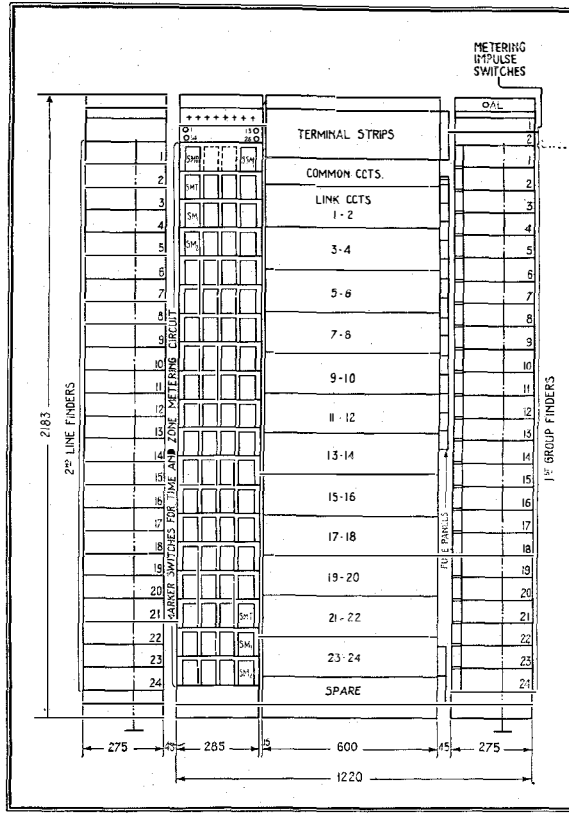

Fig. 24—Link Circuit Unit—Capacity: 24 Circuits.

The above three control circuits are common for the 3 final selector groups.

Fig. 24 shows a unit mounting the apparatus of 24 complete link circuits. It comprises a finder bay mounting 24 second line finders, a relay bay for 24 relay groups, a marker bay with metering and timing switches, and a second finder bay mounting the 1st group selectors.

The corresponding register unit, as shown in Fig. 25, consists of a marker bay mounting the switches which store the digits sent by the subscribers, a relay bay, and a finder bay. The latter bay mounts the link finders via which the registers have access to the link circuits, the impulse finders which control the selections, and the translator switches. The latter switches are only required for areas where there is no numerical relation between the digits received from a subscriber's dial and the selections to be made accordingly.

Fig. 26 shows a combined unit mounting 20 link circuits and 5 registers. This type of bay is

utilised for small sizes of exchanges in order to economise on the floor space.

Floor Space

For the three exchanges illustrated diagrammatically in Figs 18, 19, and 20, corresponding floor plans are shown in Figs. 27, 28, and 29, respectively.

For the floor plan layout of the 100 and 900 line centre exchanges, the three types of units represented by Figs. 23, 24, and 25 are utilised.

For the 10,000 line centre type exchange, high type bays accommodating 34 finders are used. The capacity of the various units is indicated in the figure.

These three floor plans further include some data on the floor space occupancy of the automatic equipment. As a measure, usually the number of square meters per line is used but

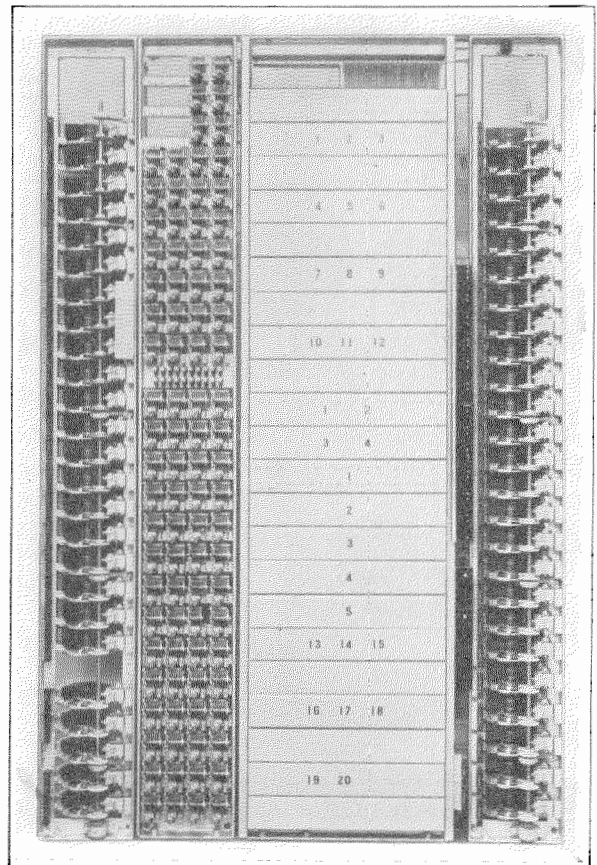

Fig. 26—Unit Mounting 20 Link Circuits—4 Control Circuits and 5 Registers.

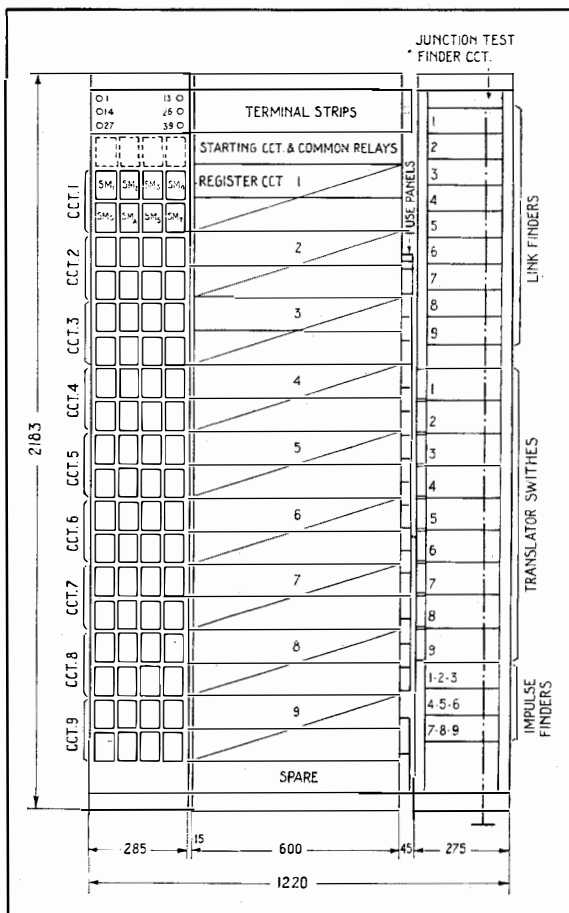

Fig. 25—Register Unit—Capacity: 9 Circuits.

attention is drawn to the fact that this practice of necessity leads to incorrect appreciation of a system as the number of lines is only one of many deciding factors. Other important factors are:

- Originating traffic per subscriber's line,
- Toll traffic per line,
- Amount of tandem traffic,
- Facilities afforded.

A striking example of the wide limits between which the amount of tandemed traffic may vary, appears from a comparison between the diagrams of the 100 and 900 line centre exchanges. Both exchanges, actually in service, carry 300 E.B.H.C. tandem traffic. For the smaller exchange, therefore, the tandem traffic equals approximately four times the traffic originated by the 100 local subscribers.

Tandeming of calls means, on the one hand, a saving on outside cable as it eliminates a large number of small size junction groups. On the

other hand, however, the amount of automatic apparatus required is increased. In order, therefore, to establish a correct comparison between different automatic rural systems both as regards floor space and cost, the outside cable plant must also be taken into account.

DISTRICT EXCHANGE
Switching Arrangement

One of the problems confronting administrations when planning the automatization of rural areas, is the choice of suitable equipment for small exchanges of capacities ranging from 50 to say 200 lines.

In certain cases, the transition from manual to automatic demands temporary interworking with manual parent exchanges whilst retaining features required later for full automatic network operation such as 5 or 6-digit dialling, time

and zone metering and timed back-release.

In many cases, the growth of small exchanges cannot be readily foreseen, and flexibility and extensibility are therefore two features of paramount importance.

The cost per line must be kept within reasonable limits without sacrificing performance, or prejudicing the introduction of future requirements.

The 7-D district type exchange equipment meets the requirements of low cost, easy extensibility and flexibility by the use of the well known 100-point gear driven finder in the dual capacity of line finder and selector, controlled by common control circuits.

Skilled help and transport facilities are not so easily found in remote country districts as in the towns, and district type equipment is therefore built in units of 50 and 100 lines capacity. The

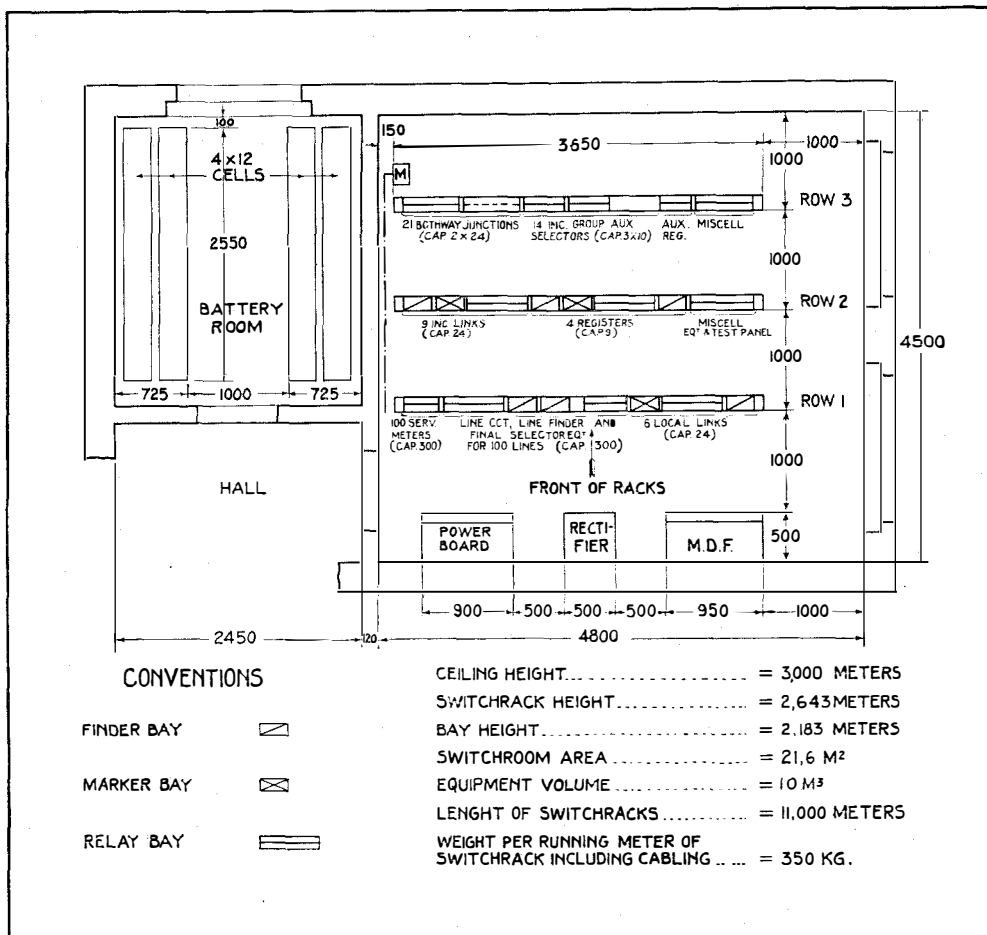
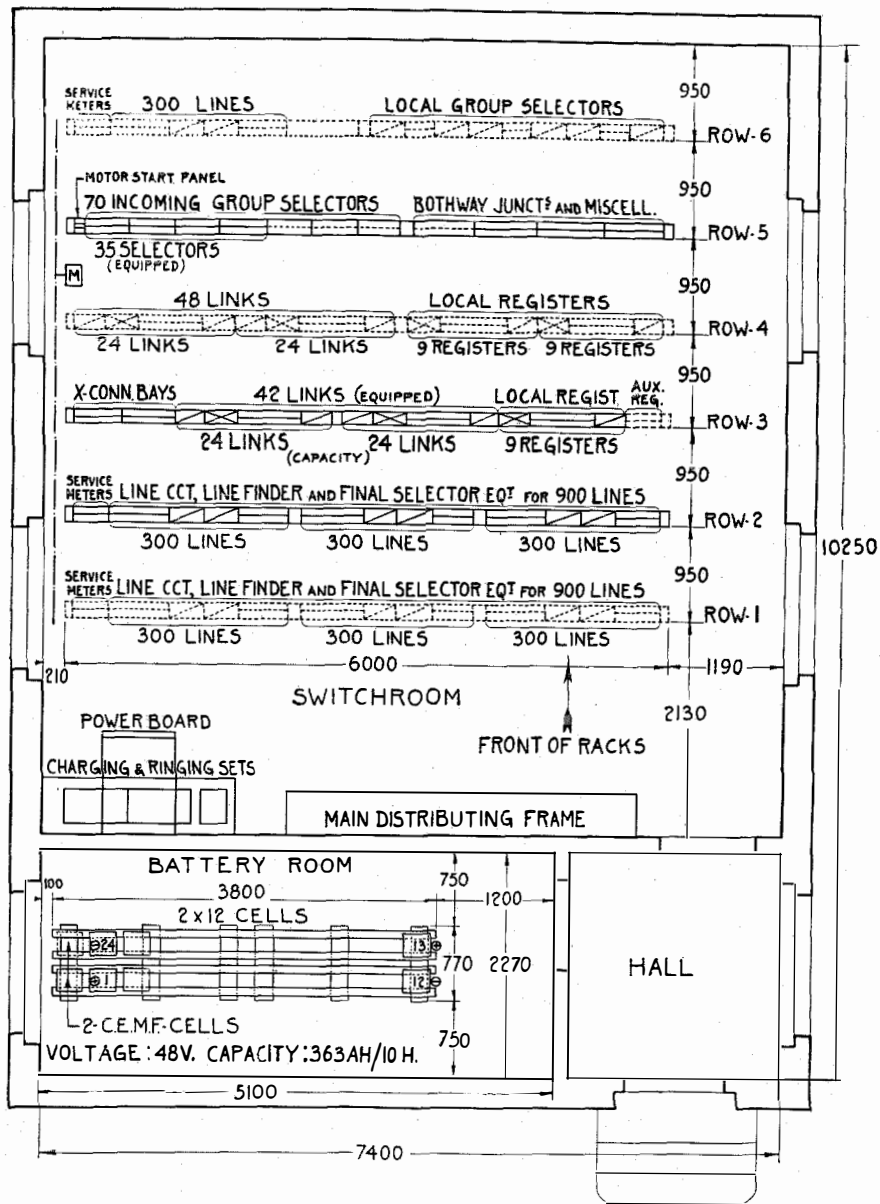

Fig. 27—Floor Plan Small Centre Exchange—300 Lines Capacity.
(See Figs. 2 and 18).



CONVENTIONS

- FINDER BAY
- MARKER BAY
- RELAY BAY

- CEILING HEIGHT = 3,000 METERS
- SWITCHRACK HEIGHT = 2,643 METERS
- BAY HEIGHT = 2,183 METERS
- SWITCHROOM AREA = 58 M²
- EQUIPMENT VOLUME = 33,4 M³
- LENGTH OF SWITCHRACKS = 36 METERS
- WEIGHT PER RUNNING METER OF SWITCHRACK INCL. CABLING } = 350 KG.

Fig. 28—Floor Plan Arlesheim Centre Exchange—2,100 Lines Capacity—Basle Rural Area—Switzerland. (See Fig. 19).

complete installation of a 50 line unit should not take more than 200 man hours.

District type equipment can be applied to:

- (a) Isolated exchanges with C.B. or L.B. parent exchanges.
- (b) Tandem exchanges or group centres with C.B. or L.B. parent exchanges.
- (c) Exchanges forming part of a full automatic 7-D rural network arranged for "open" or "closed" numbering.
- (d) Tandem exchanges forming part of a full automatic 7-D rural network arranged for "open" or "closed" numbering.

Fig. 30 shows that a very simple switching scheme has been developed for district exchanges. The junctions between the parent centre exchange and the district unit are designed for both-way operation and terminate in the district exchange on a line finder and relay group which carries both the inward and outward junction traffic. This circuit is termed "combined line finder and final circuit". When a call is originated by a district exchange subscriber, the line is found by a free junction and the subscriber is immediately connected to the parent centre exchange. If the call is to the centre or to other exchanges in the same network, it is completed over the junction. If it is local, the junction is released and the calling subscriber is transferred to a local link circuit.

Line Conditions

The maximum loop resistance of subscribers' lines is 1,000 ohms including the subscriber's set, and the maximum permissible leakage 10,000 ohms. The line circuit itself is universal, the line relay being provided with balanced windings and the resistance being such that it is suitable for high resistance transmitters. During conversation, both line relay and cut-off relay are held operated and, on every release, the cut-off relay checks the line for a loop thus functioning as a fault relay. This feature is particularly useful since it prevents reseizure of the automatic equipment when the called party releases last on incoming calls. The line circuit is also wired to terminals which permit the eventual introduction of teleprogram service.

Another feature of interest is that dead lines are indicated by opening the "c" wire which

avoids the necessity of jumpering these lines to common dead line circuits, and simplifies thereby both equipment and maintenance.

This is accomplished by arranging that the control circuit, when testing the line, tests for the presence of ground and battery, and is thus able to recognize a "c" wire which is open and connect dead line tone.

P.B.X.'s do not require any change or modification of the line circuit. The corresponding terminals are connected to ground on a special arc of the translator switch in the control circuit and on the local final selectors. The line circuit is connected over five wires to the arcs of the combined line finders and finals, the first four being used for "a", "b", "c", and metering wires, and the fifth, for searching for the calling line on originated calls and marking the wanted line on incoming calls. The searching and marking operations do not interfere with each other. The circuits were designed with the fact kept in mind that gear driven finders with ribbon cable multiples would be used; and the starting point of the design was that all finders should be of the same type with the same multiple and without any home contacts or other special arrangements on the finders themselves, thus keeping to a simple equipment layout.

Combined Line Finders and Finals

The circuits are arranged to repeat the dial impulses and to meter the calling party. The stepping relays may be of any suitable design, 250 x 250 ohms, 350 x 350 ohms, or 750 x 750 ohms. For capacities of 100 lines or less, these circuits are connected direct to the parent exchange, but for capacities exceeding 100 lines, an intermediate group selector is interposed.

A useful maintenance feature is the possibility of placing a junction out of service at its parent centre exchange. If routine or morning test, made from the parent centre, should indicate the existence of trouble in the district exchange, the junction in question can be insulated immediately.

The junction circuits are designed for 2-wire two-way working with a maximum loop resistance of 1,000 ohms, and a maximum permissible leak of 10,000 ohms. For junctions exceeding 1,000 ohms and especially where these junctions

are loaded, we recommend using 50 cycle a-c. signalling:

Where the junctions are in underground cable and where the maximum permissible leak resistance may be increased to 30,000 ohms it is possible to use d-c. impulsing up to 1,400 ohms loop. Circuits have also been made for particular cases where d-c. impulsing through repeating coils is required.

Function of Control Circuit

The control circuit is taken into use on all kinds of calls. On an outgoing call its principal function is to:

- (a) Determine the metering,
- (b) Record a local call and cause release of junction.

On an outgoing call, the metering is usually determined after the first two or three figures and, when the indication is given to the com-

bined line finder and final, the control circuit is released. On a local call, as soon as the digits dialled indicate this condition, the junction is released and the control circuit takes care of the completion of the selection.

On incoming calls, the control circuit receives the inward impulses and controls the setting of the combined line finder and final. It also arranges for P.B.X. hunting, line free, line busy, and line dead. The wanted line is tested in the control circuit itself before the combined line finder and final is positioned, and the proper tone is immediately signalled back to the calling party. When the exchange functions as a tandem district, the control circuit also takes care of connections between two exchanges in the sub-group.

Metering

For local calls, single non-repeated metering is provided and for outgoing calls, time and zone

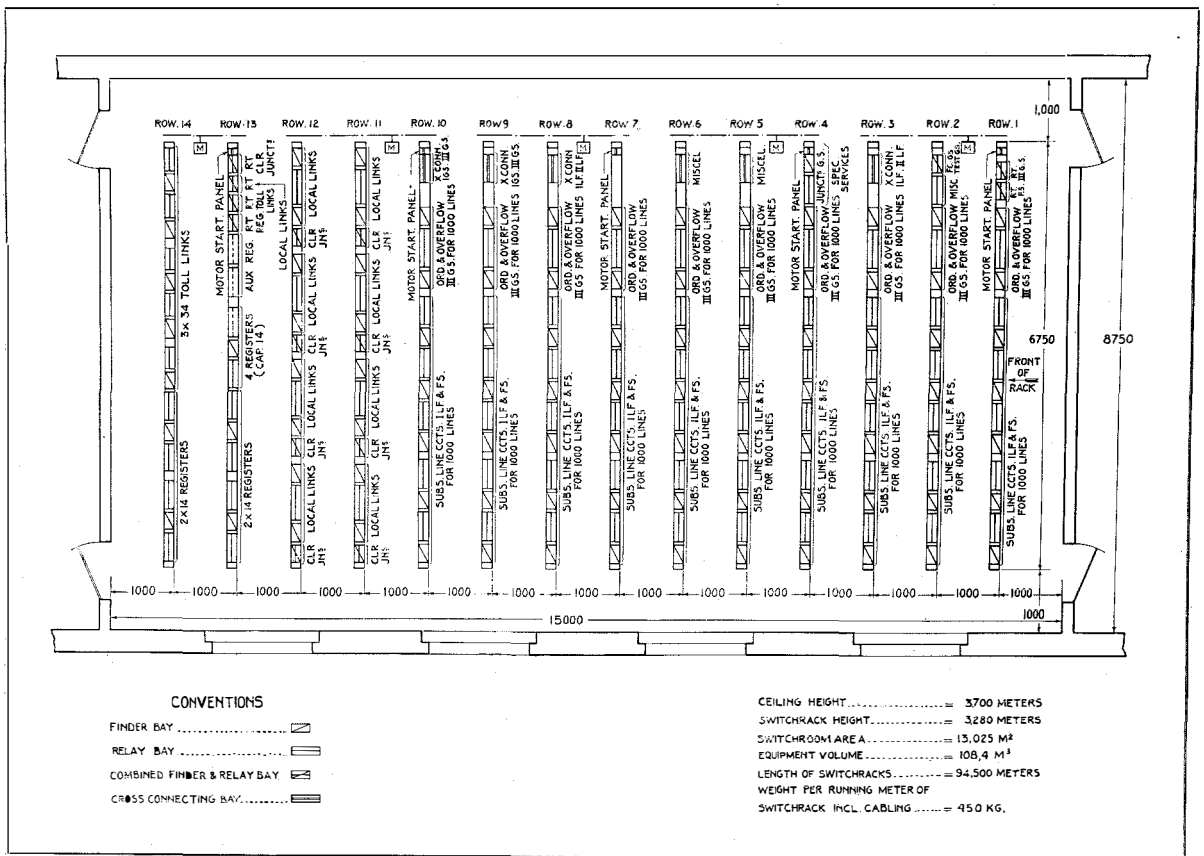

Fig. 29—Typical Floor Plan 10,000 Line Exchange. (See Fig. 20).

metering. The zone metering apparatus is located in the district exchange combined line finder and final circuits. The timing mechanism is centralised in the parent centre exchange, and the circuits are designed so that an impulse causing the operation of the subscriber's service meter is sent at the beginning of each 3 minute period.

When the exchange functions as a tandem district, time and zone metering between the exchanges in the sub-group is usually not required, these calls being generally treated as local calls, or given simple multiple metering without counting the duration of the connection. This feature can also be arranged for; or, if necessary, full time and zone metering can be introduced.

Capacities

All district exchange units employ the same type of switch and the same circuits. Two different types of equipment have been designed, one for 50 lines (Figs. 35 and 36) and the other for 100 lines (Figs. 37 and 38). These two units differ only in size, and two units of 50 lines can be coupled together to give a capacity of 100 lines.

Above 100 lines, it is necessary to terminate the junctions on a group selector unit GS, the function of which is to separate the different groups of 100 lines (Fig. 32).

Tandem District

The circuits are designed so that any exchange can function equally well as a tandem district type as well as an end exchange. In this case the tandem unit forms the center point of a group of exchanges, and the ultimate capacity of the whole group is 10,000 lines. The group selector GS can either function as an absorbing group selector with 24 outlets or as a simple group selector with 14 outlets, and in both cases 4 selections are forwarded from the parent centre exchange register circuit. The ultimate capacity of an end exchange in the group is 1,000 numbers.

District Exchange Connected to Manual Parent (Fig. 36)

In this case there is no necessity and no advantage to take up a junction to the parent exchange

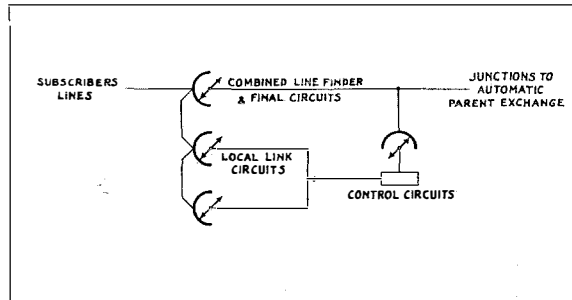

Fig. 30—Typical Diagram 100 Line District Exchange.

in advance. The circuits are therefore designed so that the calling line is first found by a combined line finder and final; but the junction itself is not called for unless the junction prefix is dialled. This method of operation is quite straightforward for capacities of more than 100 lines when the group selector GS separates the combined line finders and finals from the junction circuits proper. For 100 lines or less, it is necessary to provide this group selector, or an equivalent relay group. In this case, the ultimate capacity of the exchange is reduced to 900 lines with 3-digit numbering if a single digit prefix is required for the operator. Two-digit or 3-digit calling to the operator can be used if required and the capacity reduced accordingly.

Type of Parent Exchange

Interworking with the many different types of manual parent exchanges is arranged for in the junction circuit, leaving the remainder of the equipment substantially unchanged, and therefore permitting easy convertibility when the parent exchange becomes automatic.

On outgoing calls from district to the parent exchange, the calling party is connected to a combined line finder and final and a free control circuit. Dialling tone is given from the control. After the prefix has been dialled indicating an outgoing connection, the group selector GS of all free junctions is set in rotation searching for the calling combined line finder and final. When a free junction becomes connected, the calling signal is sent to the parent exchange and the junction is made busy at both ends. Should the parent exchange be magneto, ringing current is used to call; and if C.B., a loop.

On incoming calls the junction is made busy

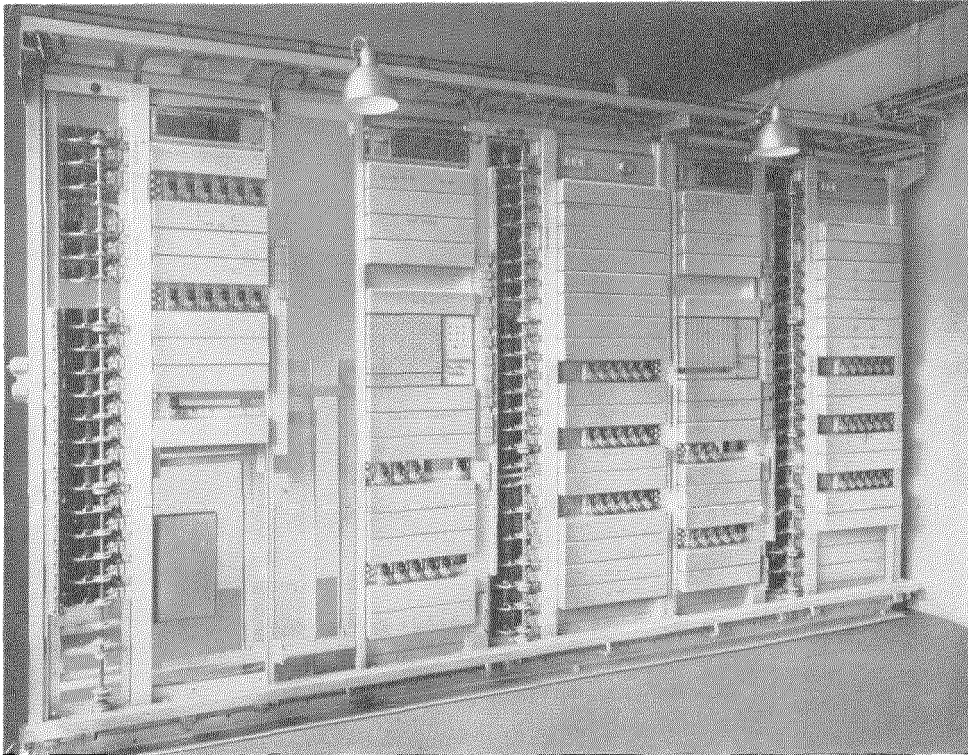

Fig. 31—Interior Aesch—200 Line District Exchange—Basle Rural Area—Switzerland.
(See Figs. 32 and 39).

as soon as the operator plugs in. The group switch hunts for a free combined line finder and final and connects the junction. Dialling tone is sent to the operator as soon as a control circuit has attached itself to the combined line finder and final. The dial impulses sent by the operator are received in the control circuit and the combined line finder and final is rotated and stopped on the wanted line. Testing of the line for "free" or "engaged" condition is made by the control circuit.

When the called subscriber releases after a completed connection, the junction signals this condition back to the operator.

Exchanges With More Than 100 Lines (Fig. 34)

When the junction is made busy by the operator, a repeating register attaches itself to it. The latter circuit transmits dialling tone to the operator, it stores the digits received and repeats

them either to the junction or to the control circuit and disconnects itself.

The repeating register could be omitted for this class of calls but the operator would have to wait for a second dialling tone before dialling the second figure. This method of operation was considered too cumbersome; and, in any case, a register is required on tandem calls to repeat

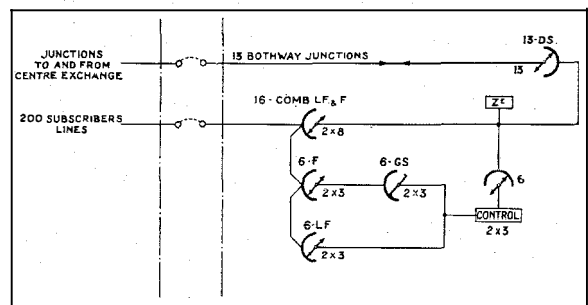

Fig. 32—Diagram—Aesch. 200 Line District Exchange—Basle Rural Area—Switzerland (See Figs. 31 and 39).

the digits which must be received by the distant office.

The register takes care of a possible permanent glow condition of the junction, disables it as long as the permanent loop exists, and releases the automatic circuits.

Toll Service

The toll service required nowadays can be divided into two classes:

- (a) That which requires a discriminating signal to be sent to tell the district exchange that the connection is from toll and that the line should be made busy in a special manner, thus permitting toll busy tone to be given to other connections to prevent breakdown, to suppress the automatic ringing, and so on.
- (b) Toll methods requiring no discriminating signal and therefore no special toll busy tone and with no prevention of breakdown. The service usually given is restricted to listening in, re-ringing and sometimes breakdown.

The sending of the toll discriminating signal

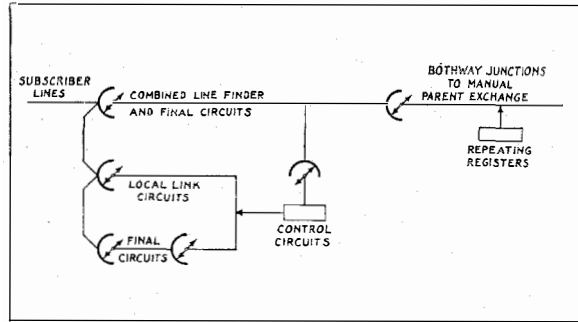

Fig. 34—Typical Diagram for District Exchange Exceeding 100 Lines.

required in class (a) concerns both the parent exchange and the district exchange. Where possible, this signal should be sent from the register, but in other cases it is found more convenient to send it from the centre end of the district junction circuit. No general rule can be laid down since the particular method to be followed depends on the layout of the area concerned, the number of junctions involved and the design of the centre register circuit.

Equipment

A typical 50 line unit is shown in Fig. 35. It includes equipment for:

- 50 Subscribers' line circuits,
- 50 Service meters,
- 5 Combined finder and final circuits,
- 5 Both-way junction circuits,
- 2 Local link circuits,
- 2 Control circuits,
- 1 Ringing and tone circuit,
- 1 Power control circuit,
- 1 Alarm circuit,
- 1 Motor starting circuit.

Another 50-line unit with three local links instead of two is shown in Fig 36.

The weight of a 50 line unit fully equipped as shown in Fig. 35 is 334 kilogrammes, unpacked. When packed and ready for shipment the weight is 637 kilogrammes and the dimensions of the packing case are 200 x 80 x 175 cm. If required, the unit can be shipped with the subscribers line cables to the main frame already soldered to the arcs of the line finders. The battery charging equipment is usually shipped separately together with the tools, routine test box, and spare parts.

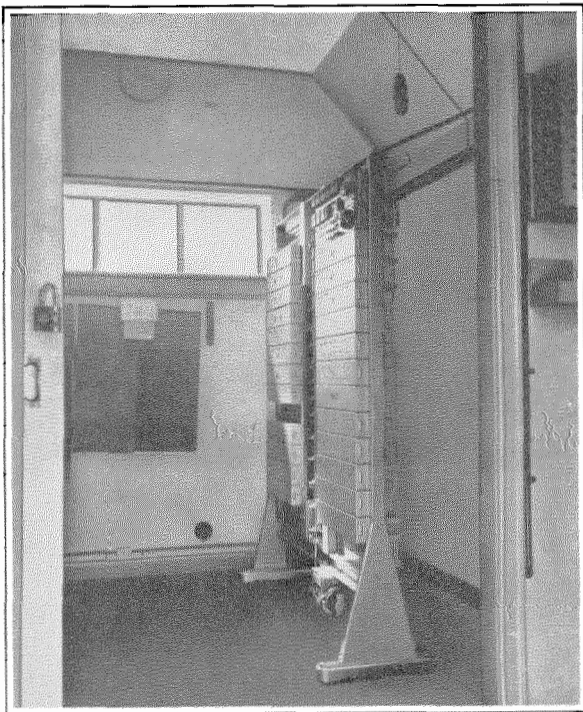

Fig. 33—Interior Valensbaek District Exchange—Denmark. (See Fig. 36).

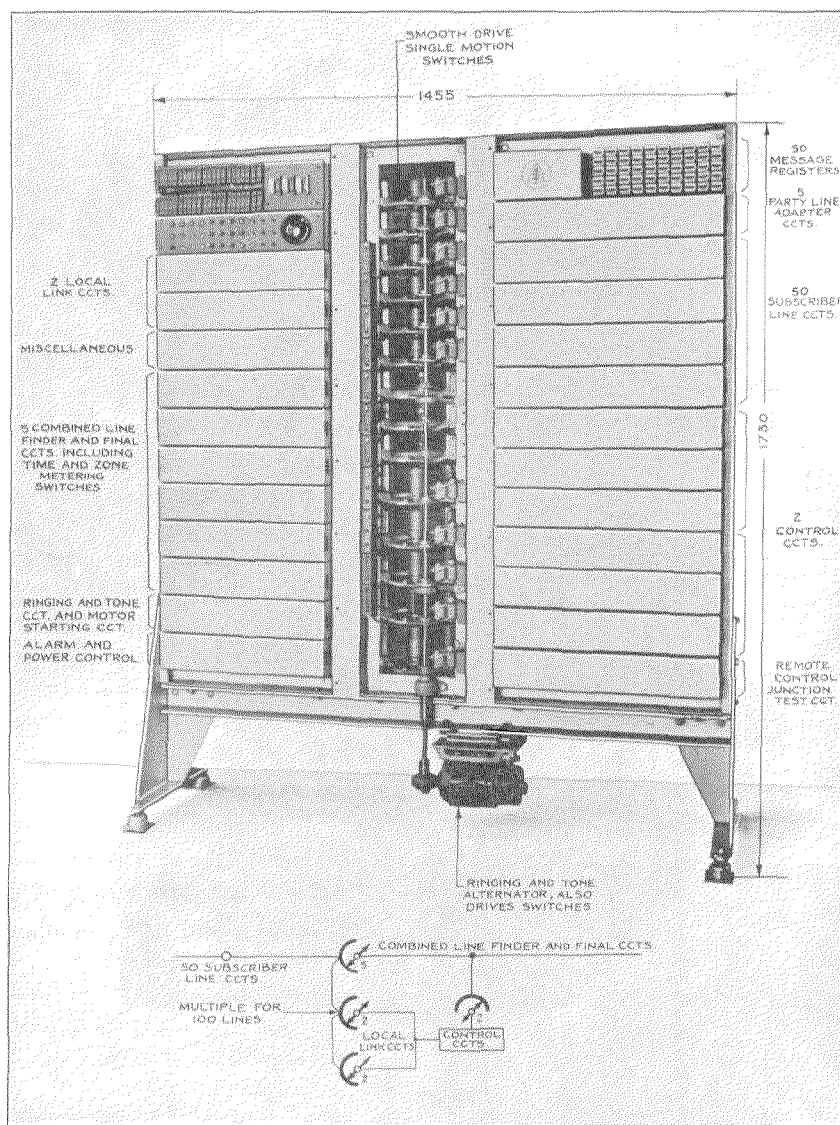

Fig. 35—50-Line District Exchange Unit—Dimensions 1,730 by 1,455 mm.

A typical 100 line unit is shown in Fig. 37 and includes equipment for:

- 100 Subscribers' line circuits,
- 100 Service meters,
- 9 Combined finder and final circuits,
- 9 Both-way junction circuits,
- 4 Local link circuits,
- 3 Control circuits,
- 1 Ringing and tone circuit,
- 1 Power control circuit,
- 1 Alarm circuit,
- 1 Motor starting circuit.

Fig. 31 shows a 200-line district exchange with two 100-line units and a junction unit.

The weight of a 100-line unit fully equipped as shown in Fig. 37 is 470 kilogrammes, unpacked. When packed ready for shipment the weight is 810 kilogrammes and the dimensions of the packing case are 280 x 70 x 175 cm. The unit is mounted on a channel iron base which carries the horizontal shafting and the reduction gear. The motor is mounted at the side and can be coupled to two or more units. A combined shaft driving motor of 1/30 H.P. and ringing and tone alternator of 5 V.A. is used.

PART III

FACILITIES

1. *Operating Limits*

The normal operating potential of all circuits is 48 volts. The permissible variation is from 44 to 52 volts.

2. *Junction Working*

Junction circuits may be either both-way or one-way, and are arranged for d-c. or 50 cycle a-c. signalling. The limits for d-c. signalling are:

Loop resistance	0 — 1,200 ohms.
Insulation	10,000 ohms minimum.

When idle, the junctions are not under potential.

The line relays are connected in bridge and are operated by the application of 48 volts and ground at the calling end. Signalling and impulsing are done metallically, thereby eliminating ground potential influence and interference to other circuits.

Junction circuits between districts and centres are usually both-way and grounded when idle. Junctions are made busy for connections in either direction by the insertion of a plug in the break jack at the centre exchange.

Junctions for interworking with surrounding C.B. or L.B. offices can be arranged for ringdown or lamp signalling, for both-way clearing and tandem working.

3. *Subscriber Lines*

Line circuits can be supplied with a single winding line relay or with a balanced two-winding line relay. Terminals are provided for connection to radio diffusion equipment. The line limits are:

Loop resistance	0—1,200 ohms including set.
Insulation	10,000 ohms minimum.
Dial speed	8-12 steps per second.

4. *False Calls*

Line faults are routed to false call circuits from which the line can be tested without plugging in

at the M.D.F. This is possible because the bridge in the link circuit can be disconnected and reconnected at will from the false call circuit.

If it is necessary to locate a false call, this is done by checking the position of the finders. Link circuits are identified by a lamp flashed from the false call circuit.

In districts or small centres, permanent loops are locked up in the subscriber line circuits and all switches are released. A false call busies a test line, and when this line is called by the maintenance man at the main or distant exchange, busy tone is given. Faulty lines are located by means of lamps and keys.

For large centre exchanges, a special false call identification finder can be provided for each group of 100 lines. It, in combination with a lamp display panel, indicates the exact number of the faulty line.

5. *Two- and Ten-Party Lines*

The 7-D Rotary System provides for the connection of two-party lines with facilities of:

- (a) Secret service—without revertive calling, or
- (b) Non-secret service—with revertive calling.

Ten-party line equipment has been developed which provides for both secret service and revertive call facilities.

6. *Coin Boxes*

There are two methods of coin box operation:

- (1) Simple single-slot coin box restricted to local service, requiring some barring scheme to prevent a coin box subscriber from obtaining other than local connections.
- (2) Where time and zone metering is already introduced, multi-slot coin boxes may be used and the value of the coins inserted checked against the number dialled.

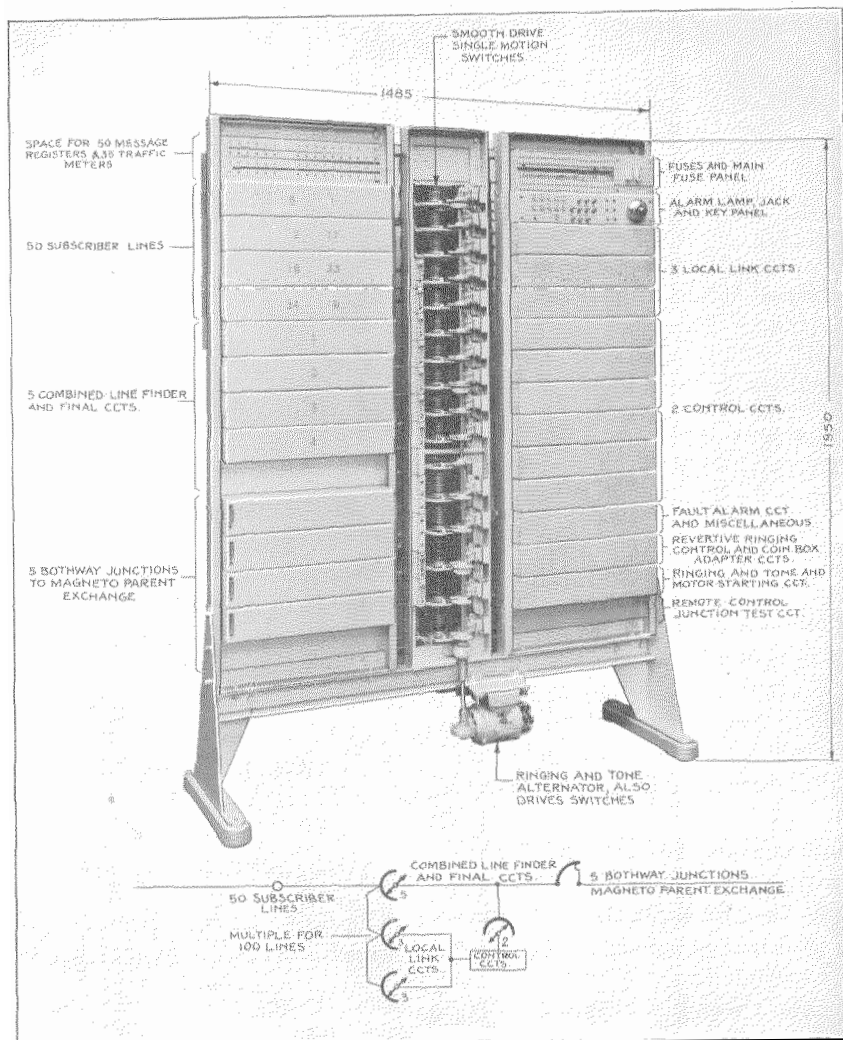

Fig. 36—50-Line District Exchange Unit—Dimensions 1,950 by 1,485 mm.

7. P.B.X. Groups

Any group of regular lines connected consecutively in the arc can be changed into a P.B.X. group by connecting a wiring strap on the final multiple.

P.B.X. lines can be called individually, which may be necessary during the night when some lines are through-connected to stations at the P.A.X. P.B.X. hunting takes place when the called line is busy. If all lines are busy, the final stops on the last line and busy tone is given.

8. Dead Lines

On dead lines, a special tone is given from the final to the calling party.

9. Wrong Numbers

Busy tone is given to the calling party.

10. Numbering

Open numbering with 2, 3, or 4-digit prefix and 3, 4, 5, or 6 numerals.

Closed numbering with 3, 4, 5, or 6 numerals.

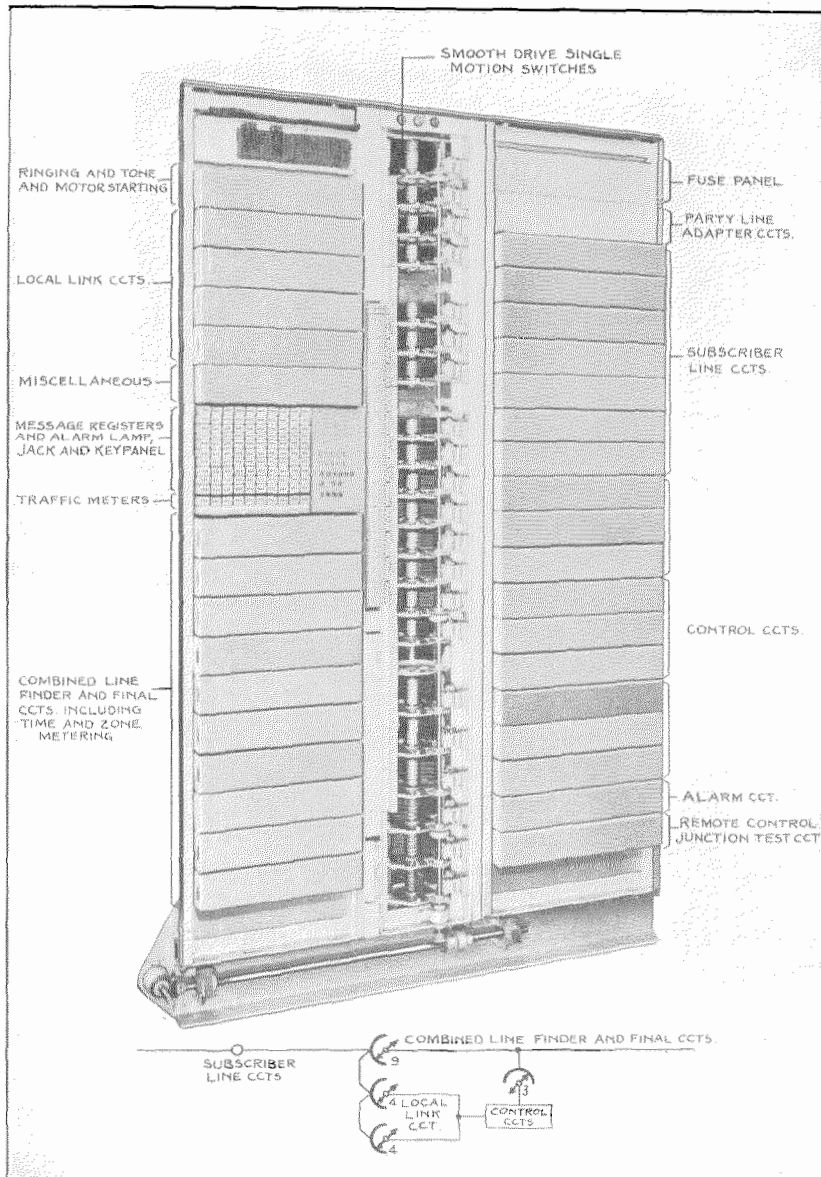

Fig. 37—100-Line District Exchange Unit—Dimensions 2,400 by 1,455 mm.

11. Time and Zone Metering with Centralised Timing

Local calls are metered once only, and are not limited in duration. Other calls are metered at the beginning of each three-minute period. The tariff depends upon the designation of the call, the number of tariffs and meterings being fixed according to local requirements. If required, the number of meterings is reduced at night, the in-

roduction of the reduced rate being controlled by a clock contact.

Conversation may be unlimited, or limited to 6, 9, or 12 minutes, after which the connection is automatically broken down. A warning tone is given 10 or 30 seconds before breakdown.

The timing of conversation is centralised in the centre exchange, thus reducing the amount of material required in district exchanges and

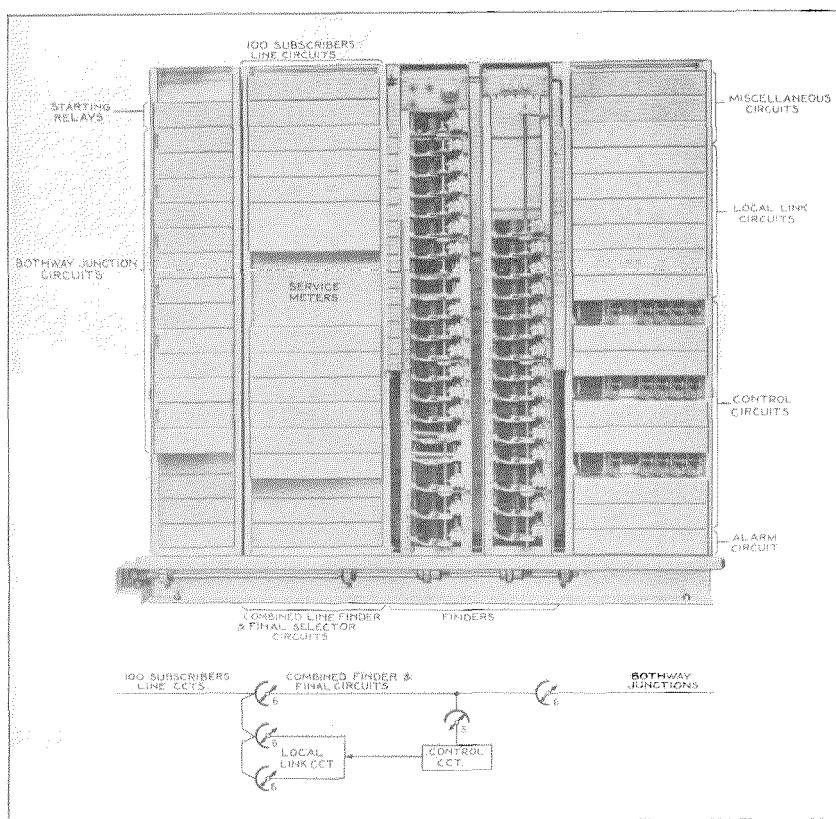

Fig. 38—100-Line District Exchange Unit—Dimensions 2,145 by 2,170 mm.

avoiding the necessity of providing an accurate clock in each exchange.

12. C.L.R. Connections with Time and Zone Metering

The C.L.R. operator is called by a two-digit number. When the connection is set up, the corresponding metering tariff is sent back by a series of impulses from the operator's positional circuit to the metering apparatus located in the exchange to which the calling party is connected. Should the operator reroute the connection, the tariff is cancelled by a long impulse and the new tariff is sent back.

Timing of the conversation is centralised in the main exchange. At the commencement of each three-minute period, an impulse is sent back to the originating exchange causing the required number of impulses to be sent to the subscriber's meter. If the operator interferes in a connection by depressing the splitting key, timing is stopped until the key is restored.

The duration of conversation can be limited, or can be unlimited, depending upon the load on the toll trunks in a certain direction. Day and night tariffs are taken care of by the metering circuit at the originating exchange.

13. L.D.D. and National Dialing

Automatic interworking with other cities and networks is possible, using the regular toll trunks and switches also used by toll operators (For time and zone metering see Section 11 above).

The tariff is set up as for rural connections and is determined by the prefix and some figures of the numeral.

The duration of conversation may be limited or not depending upon the load in each direction.

14. Fire and Police Service

When required, uniform 2-digit codes may be used for "Fire" and "Police". Calls to these services are then directed to the nearest local fire or police station.

15. Toll Service

The system is designed to include the following different toll features:

- (a) Automatic ringing,
- (b) Listening-in and offering,
- (c) Re-ring of subscriber after conversation,
- (d) Breakdown of busy condition,
- (e) Toll busy tone,
- (f) Prevention of listening-in on toll busy connection,
- (g) Prevention of breakdown on toll busy connection,
- (h) Warning tone when operator enters on existing connections.

In large rural networks, the most usual requirements are those mentioned under (a) and (b).

16. Tie Lines

If warranted by the mutual traffic, two exchanges may have direct tie line connections.

17. Delayed Back Release

In the event of the calling party holding after the release of the called party, the connection is released and all junctions are liberated after a delay of thirty seconds. Continuation of metering is also prevented in this case.

This feature safeguards the calling subscriber against excess metering due to slow release and delay on the part of a P.B.X. operator to respond to the clearing signal.

18. Forced Release

In case of incomplete dialing, or if the selection does not progress, the connection is forcibly released after 30 seconds.

19. Fault Alarms

Alarms are given, for instance, for high or low voltage, ringing current failure, blown fuses, blocking of circuits for more than thirty seconds, etc.

In unattended exchanges, alarms are signaled via the regular junctions to the main or nearest attended exchange. If required, alarms may be identified by a visible or audible code, or by a number of lamps, preference being given to the most urgent alarm. Alarms may also be classified

as urgent or non-urgent, and identified as such by two lamps at the nearest attended exchange.

20. Routing Testing

A.—Manual Routine Testing

The equipment is arranged for manual routine testing. Quick and simple tests can be made with a portable test box connected to the circuits by means of plugs.

B.—Remote Control

All junctions of each exchange of the rural network can be tested from the main or centre exchange. Both-way junctions can be tested in either direction.

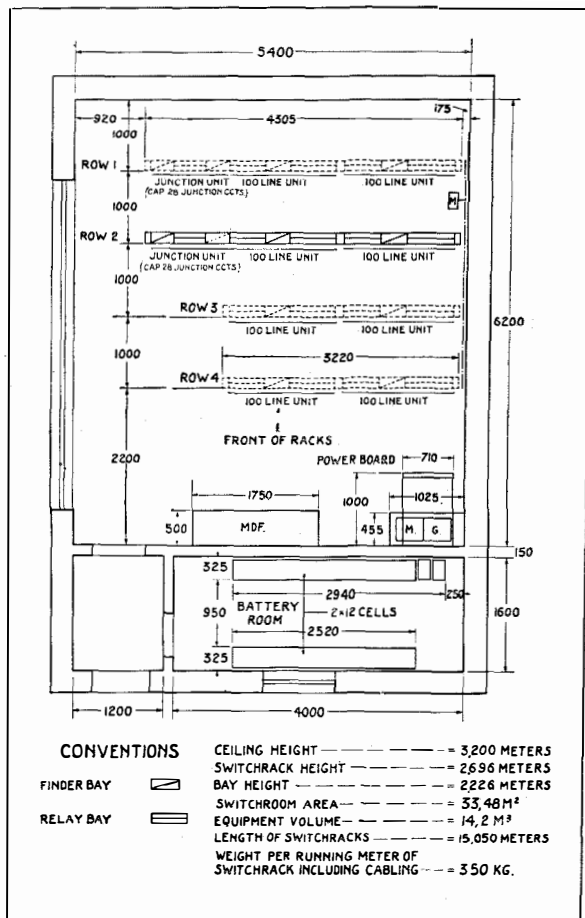

Fig. 39—Floor Plan—Aesch District Exchange—Basle Rural Area—Switzerland—800 Lines Capacity (See Figs. 31 and 32).

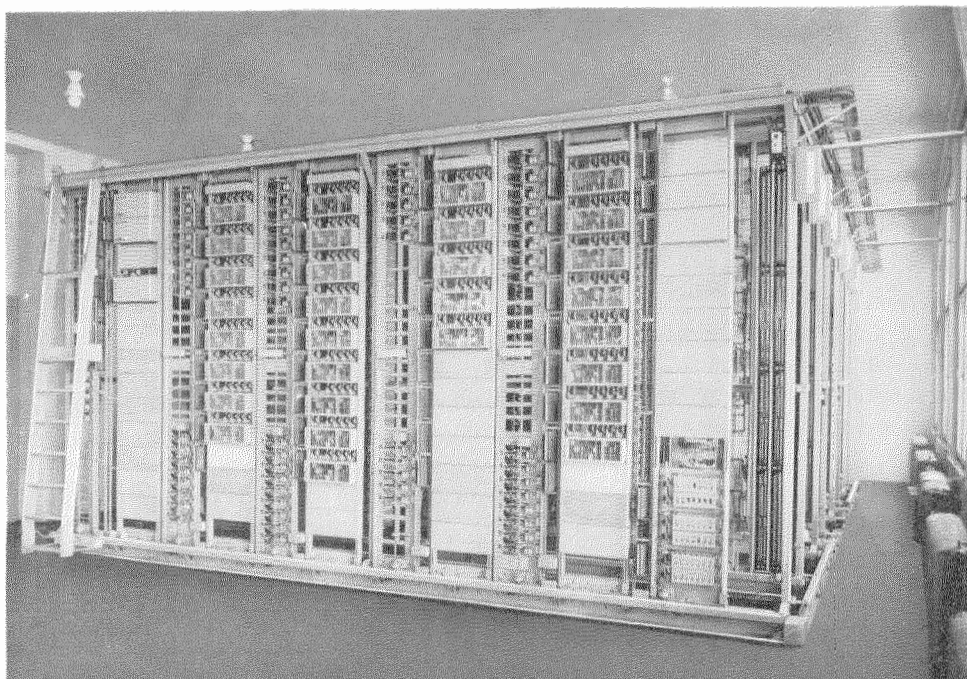

Fig. 40—Interior Kosice Centre Exchange—Czechoslovakia.

21. Special Services

Special services are reached by dialing a two-digit number. If required, single metering is applied under the control of the operator.

22. Number of Outlets on Group Selector

There are 16 outlets on the local 1st group selectors in centre. The setting of the group selector is done on the marking principle, direct from the register. Incoming group selectors may have 14, and absorbing selectors 19 outlets.

23. Traffic Recording

Means are provided to check the number of local calls, special service calls, outgoing calls and the number of conversation units per metering zone, on repeated metering calls. If required, two sets of meters can be provided, one set connected during the day and the other during the night.

Traffic meters may be connected to junctions,

registers, controls, etc. For both-way junctions, traffic can be checked in each direction separately. The meters are connected to the various circuits by means of plugs, and may be fixed on a frame or in a portable box for use in the exchanges.

24. Interworking

The system is arranged to interwork with large city exchanges or networks of the rotary, step-by-step, or any other type, and with surrounding C.B. or L.B. offices with ringdown or lamp signalling. Connections between two manual exchanges can be tandemed through the automatic exchange. Clearing and metering facilities are given as required.

25. Miscellaneous Facilities

Circuits have been prepared for tax indicators, battery feeding for P.B.X. lines, feeding for connections between main and extension sets, etc.

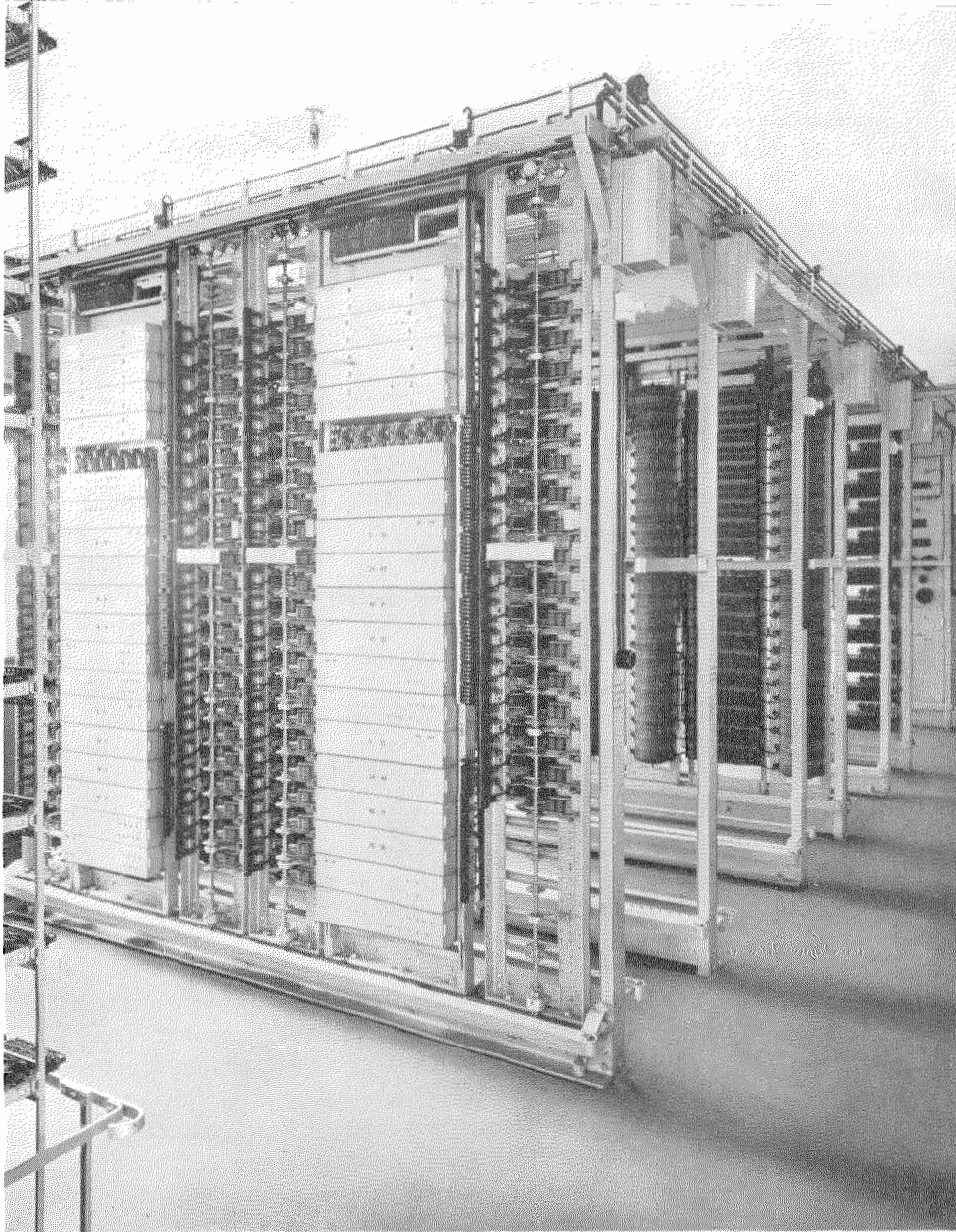

Fig. 41—Pension Institute P. B. X. at Prague—Czechoslovakia.

Wide Band Transmission Over Balanced Circuits*

By A. B. CLARK, Fellow A.I.E.E.

Bell Telephone Laboratories, Inc., New York, N. Y.

Equipment for handling frequency band widths of the order of 1,000,000 cycles or more for telephone, telegraph, and television purposes was described in a recent A.I.E.E. paper "Wide Band Transmission Over Coaxial Lines." This previous paper confines itself to the coaxial line structure, but points out that broad band transmission is also applicable to balanced conductor systems. The present paper discusses briefly some of the possibilities of the more familiar balanced circuits, circuits essentially as they now exist in the present plant being first considered, following which are considered circuits obtained by new construction. Wide band transmission over balanced circuits offers interesting possibilities both in the present plant and for new construction.

A HIGH degree of "electrical balance" has been for a long time a fundamental requirement of telephone transmission lines. This has been required not only to prevent interference entering into telephone circuits from other types of electrical circuits but also to prevent mutual interference between the closely adjacent telephone circuits on open wire lines or in cables.

As used here, the term "electrical balance" refers to the two sides of a telephone circuit. To secure such balance, the aim has been to construct the go and return conductors of each circuit of the same gauge and material and to locate them symmetrically with respect to earth and to surrounding conductors. The aim has also been to apply to each circuit terminal apparatus symmetrical with respect to its series impedances and shunt admittances to ground.

In the central offices, to be sure, unbalance in apparatus has been employed frequently for simplicity and convenience. In toll circuits, however, such office unbalance has been electrically separated from the outside plant by the use of repeating coils or otherwise. In local circuits the high standard of balance required for toll circuits has not generally been necessary since the exposures to interfering fields are less severe and the range of speech levels is much smaller. However, when local circuits are connected to toll circuits the unbalances are kept electrically separated from the toll circuits by the use of

repeating coils. In recent years the tendency to the use of higher frequencies in communication circuits, the increase in the strength of interfering fields, and the development of highly efficient amplifiers has led to constantly more exacting requirements in electrical balance of telephone circuits.

The development of multichannel systems by carrier methods employing constantly increasing frequency ranges has placed particularly exacting requirements on such electrical balance. In a recent paper¹ on "Communication by Carrier in Cable" are described the balancing methods which have been developed to permit the use of an increased frequency range in such cables. The recently published paper² on "Wide Band Transmission Over Coaxial Lines" by L. Espenschied and M. E. Strieby, points out the possibilities and possible requirements for very much wider frequency ranges. In that paper, coaxial lines are proposed which are particularly interesting in that they abandon electrical balance altogether and depend entirely on metallic shielding.

For such wide frequency range transmission, very interesting and important questions are raised, first as to the extent to which such wide bands can be placed on existing types of structure which are based on balance and, second, as to whether new construction designed particularly for such wide bands should depend on balance or shielding alone or a combination of the two. It is the purpose of this present paper to discuss these questions.

As noted in the Espenschied-Strieby paper, the

¹For all numbered references see list at end of paper.

* Republished by permission from *Electrical Engineering*, January, 1935.

apparatus described for broad band transmission on concentric structures would also serve for other types of line structures. There would, of course, be problems in either balancing the apparatus or isolating its unbalances from the line structure. For the purposes of the present paper it is assumed that there will be no important reaction from the apparatus standpoint on this consideration of line balance and shielding.

Existing Cables

The attenuation of pairs in existing cables has a characteristic with respect to frequency generally similar to that of coaxial conductors but is, naturally, considerably higher because of the smaller physical dimensions and higher dielectric losses of the cable pair. For example, at 1,000,000 cycles an ordinary 19 gauge cable pair has an attenuation of about 18 decibels per mile, an ordinary 16 gauge pair about 14 decibels per mile, while a small sized coaxial structure has an attenuation of about 6 decibels per mile. This means more repeaters for the cable pairs, three times as many for 19 gauge and a little more than twice as many for 16 gauge. Also, it means more difficulty in maintaining stability of transmission, including overcoming of the variations due to the effect of temperature changes.

Stable and highly linear repeater gain can be produced so readily nowadays, thanks to the negative feed-back amplifier invented by H. S. Black (see reference 3) that the idea of such high attenuations is no longer appalling even though on 16 gauge pairs it means repeaters spaced only about 4 miles apart. Overcoming the transmission variations due to temperature, with automatic regulators, introduces no fundamentally new problems, but, of course, the complexity and precision of regulation must be considerably higher due to the considerably larger variations.

Crosstalk, of course, must be given special consideration. First of all, it is necessary to restrict transmission of a given high frequency band to only one direction in a single cable; the other direction must be supplied by another cable¹ or other separate transmission medium.

Considering transmission in one direction only,

if only one pair in a cable is set aside for high frequency transmission of, say, a million cycle band, most, but not all, of the crosstalk difficulty can be avoided. However, the fact must be reckoned with that if one pair in a cable is singled out and an amplifier is applied having 60 decibel or more gain at a point intermediate between voice-frequency repeater stations, the amplifier will have a strong tendency to sing due to crosstalk between the pairs connected to the input and output and the other pairs in the cable. If two cables are available, this difficulty can be avoided by jumping from one cable to another every time the high frequency amplification is introduced. If two cables are not available, overcoming the difficulty may call for the insertion of high-frequency choking devices in some or all of the low-frequency cable conductors at points where high frequency amplification is introduced.

Considering now crosstalk between two circuits in a cable transmitting in the same direction, assuming the amplifier difficulty to have been overcome, tests have been made on various cables in the field, from which these conclusions have been drawn. For telephone message purposes it is probably uneconomical to apply million cycle frequency ranges to more than a single pair in an existing cable. However, with television, the crosstalk requirements are much less exacting. This is because the range of intensities necessary for a good television image is much less than is needed to accommodate message telephone subscribers and, therefore, a considerably larger ratio of extraneous current to maximum signal current can be tolerated. Tests indicate that two or more television channels, each 1,000,000 cycles wide (possibly wider), can be transmitted over separate properly arranged pairs in the same direction in a single existing cable without serious disturbance due to crosstalk.

With respect to noise in existing cables, the matter of principal concern is noise produced in telephone offices by apparatus working on other circuits, since the natural shielding afforded by the cable sheath largely eliminates noise from outside sources. Two methods are available for control of the noise produced in telephone offices: (1) Introduction of high-frequency choking devices in all wires not assigned to carrier service

at the points where the cables enter offices in which noise is produced; and (2) attack on noise at points where it is produced by introduction of spark-killers and individual high-frequency choking devices. The lenient noise-to-signal ratio requirement for television mentioned above makes high-frequency television application much easier than message telephone application.

While a million cycle frequency range over more than one pair in an existing cable seems unlikely for telephone message purposes, there are interesting possibilities in the use of lower maximum frequencies. For example, it seems likely that twelve same-directional telephone channels may be obtained from each one of a large fraction of the pairs in existing toll cables and that the crosstalk between the pairs may be kept within proper bounds by simple balancing methods previously described.¹

Open Wire

With open wire, conditions are just about the reverse of those with cable. A mile of open wire has an attenuation of only about one decibel at a million cycles as compared to 6 decibels for the small sized coaxial conductor. However, overcoming crosstalk between different pairs of wires on a pole line presents very formidable problems, while avoiding interference from and to radio systems may be even more formidable.

The attenuation of open wire pairs has been checked up to several million cycles and it has been found that it behaves as expected. When there is little crosstalk from the high frequency band to other wires in the lead the attenuation-frequency characteristic is smooth; when there is severe crosstalk, the characteristic is bumpy. For a given length of circuit the attenuation is small compared with that of the small sized coaxial conductor and the variation due to changing weather conditions is also small—about one-third that of the coaxial. It is interesting to note, however, that the percentage change in attenuation for the coaxial is less than half that for the open wire line. While it is, of course, evident that the open wire transmission variations depend in part on changes in the series resistance of the wires due to changing temperature and in part to changes in leakage and capacitance due to varying weather conditions,

automatic transmission regulating systems similar in general principles to those already developed for other purposes should be adequate to maintain the required stability.

Crosstalk between different circuits becomes so severe at high frequencies that special transposition treatment or respacing of the wires becomes necessary. Minimizing interference from and to radio systems calls for a high degree of balance which may or may not dictate changes in the wire configuration. Here again it is necessary to distinguish between the requirements for television and for message telephone. Tests indicate that, in view of the more lenient television requirements, several million-cycle television channels can be transmitted over different pairs of a single open wire line without serious disturbance and that to do this it will not be necessary to make radical changes in present wire configurations.

New Cables—Comparison of Different Types

For new construction, if television is not considered, effective carrier telephone systems may be set up by various methods. One might be a very broad band method, a good example of which is given in the Espenschied-Strieby paper. Another might be a much narrower band method using conductors similar to those in an ordinary cable. In the one case many telephone channels are obtained from a single pair by dividing up a frequency range, say 1,000,000 cycles wide, into somewhat more than 200 channels. In the other case only 20 odd channels are obtained per pair of wires and use is made of 10 pairs of wires to obtain the same total number. It is too early to say which of these plans might be best under various practical conditions.

To meet future television needs, it may be necessary to provide for transmission of continuous frequency bands 1,000,000 cycles in width or wider. It is interesting to compare the coaxial with balanced pairs surrounded by individual shields for such transmission.

For 6 decibel loss per mile at 1,000,000 cycles, it works out that a solid copper coaxial unit with the rubber disk insulation described in the Espenschied-Strieby paper has an internal diameter (inside of shield) of about 0.25 inch. For the

same attenuation a pair of wires, each the same size as the central wire in the coaxial unit (70 mils diameter), insulated with rubber disks and with a copper shield, will have an inside diameter under the shield of about 0.4 inch. For outside conductors or shields made of lead the inside diameters become about 0.4 inch for the coaxial and 0.5 inch for the balanced pair. Therefore, if the thickness of the outer conductor is determined by mechanical considerations rather than outside interference, the coaxial is smaller and cheaper. As the frequency is made higher, the shielding from outside interference afforded by the surrounding cylinder increases, so that at very high frequencies mechanical considerations alone control, and the coaxial is clearly cheaper than the balanced shielded pair.

In the frequency range up to about 1,000,000 cycles, however, interference from outside sources, including natural static and radio, must be considered in determining the thickness of the surrounding cylinder, and the cost comparison is not so clear. It will be evident that as regards shielding, the balanced pair is at a large advantage because the two sides of the circuit are designed to be electrically similar. By proper care in manufacture this balance readily can be made sufficient to insure adequate shielding with a surrounding lead tube of thickness determined solely by mechanical considerations.

With a coaxial structure, however, it appears likely that to keep interference within proper bounds, a simple lead tube must be made considerably thicker than required by mechanical considerations, so that such a structure would probably be more expensive than a lead-shielded pair. However, by adding other materials an adequately shielded coaxial unit can be constructed which will have a considerably thinner outside wall.

For example, there is described in the Espenschied-Strieby paper a coaxial unit in which the inside diameter is minimized by first using copper tapes, the thickness of wall is minimized by adding thin iron tapes, and the whole is made waterproof by a thin surrounding lead tube. This results in a unit of smaller inside and outside diameters than those of a lead tube surrounding a balanced pair of like attenuation. Since, however, the wall of the coaxial con-

ductor is thicker and the structure more complicated, the costs of the two units are estimated to be not greatly different when they are designed for the frequency range up to 1,000,000 cycles. A minor advantage for the balanced pair remains, however, in that, whatever may be the top frequency, there is no limitation as to the lowest frequency permissible for interference reasons.

Other Considerations

In the above discussion of new cable construction the amplifiers and transmission regulators required have not been mentioned. If similar conducting and insulating materials are used, shielded balanced pairs and coaxials have similar transmission-frequency characteristics. The variations with temperature are also similar. The factors which limit the overall amplifications are also the same. There is only one important point of difference between the amplifiers required for the two systems. This is the necessity for input and output transformers to be balanced to ground with the balanced pairs. The excellence of balance required, of course, depends upon the extent to which balance is relied on to reduce the required thickness of sheath. In view of the fact that very thin sheaths are impracticable for mechanical reasons it appears probable that only very modest requirements as to balance need be imposed on the design of these transformers.

To provide several circuits in new cables for meeting wide band television needs, another method may be considered, that is, to provide balanced pairs considerably larger in size than ordinary pairs and with the rubber disk form of construction, or other form giving low dielectric losses, but with no shields at all around the individual pairs. Shielding from outside disturbances would be provided adequately by the outside lead sheath of the cable. Crosstalk between different pairs would be the principal concern. If all of the high frequency pairs were to be used for television transmission, the crosstalk requirements, as already mentioned, would not be severe, so that by careful design the crosstalk could readily be kept within proper bounds—of course, restricting transmission of all wide frequency bands to a single direction within a single sheath. Such high-frequency

balanced pairs might prove suitable for telephone message circuits also. If not, the high frequency pairs would be restricted to television only, and other pairs, worked at lower frequencies, would be provided for telephone message service.

Summary

It appears feasible under certain conditions to transmit continuous frequency ranges of 1,000,000 cycles or more over conductors in the existing telephone plant. This may some day prove very important, particularly if the art of television develops to the point of calling for such wide frequency range circuits to carry television im-

pulses around the country as sound programs are now carried.

For new construction, the balanced type of circuit, as well as the unbalanced coaxial circuit, offers many interesting possibilities.

References

1. "Communication by Carrier in Cable," by A. B. Clark and B. W. Kendall, *Electrical Engineering*, v. 52, July, 1933, p. 477-81.
2. "Wide Band Transmission Over Coaxial Lines," by L. Espenschied and M. E. Strieby, *Electrical Engineering*, v. 53, October, 1934, p. 1371-80; also *Bell System Technical Journal*, October, 1934, and *Electrical Communication*, October, 1934.
3. "Stabilized Feed-Back Amplifiers," by H. S. Black, *Electrical Engineering*, v. 53, January, 1934, p. 114-20.

The New Standard Repeater Equipment

By J. S. LYALL, B.Sc., A.M.I.E.E., A.C.G.I.

Standard Telephones and Cables, Limited

THE purpose of this brief article is to provide a concluding chapter to the paper published over two years ago,¹ in which was described the features and advantages of a new principle of construction for transmission equipment. Since the publication of this article, the new type of equipment has passed satisfactorily through the various phases of manufacture and installation in large quantities.

Telephone Administrations have been quick to realize the advantages offered in the new

equipment and repeaters are now being operated with success in many countries, including Italy, Switzerland,² Sweden, Finland, and Brazil. The general principles have also been adopted as standard by the British Post Office, the equipment at present being supplied to this Administration differing only in points of minor detail.

Experience so far has shown definitely that apart from the ultimate advantages offered in space saving and simpler maintenance, the new

²A description of the St. Moritz repeater station, equipped with the new "Standard" repeater equipment appears in *Technische Mitteilungen T.T.*, No. 1, 1935, the official organ of the Swiss P. T. and T. It is stated therein that "all the equipment has functioned perfectly since being placed in service."

¹"The New Standard Repeater Equipment" by J. S. Lyall, *Electrical Communication*, October, 1932.

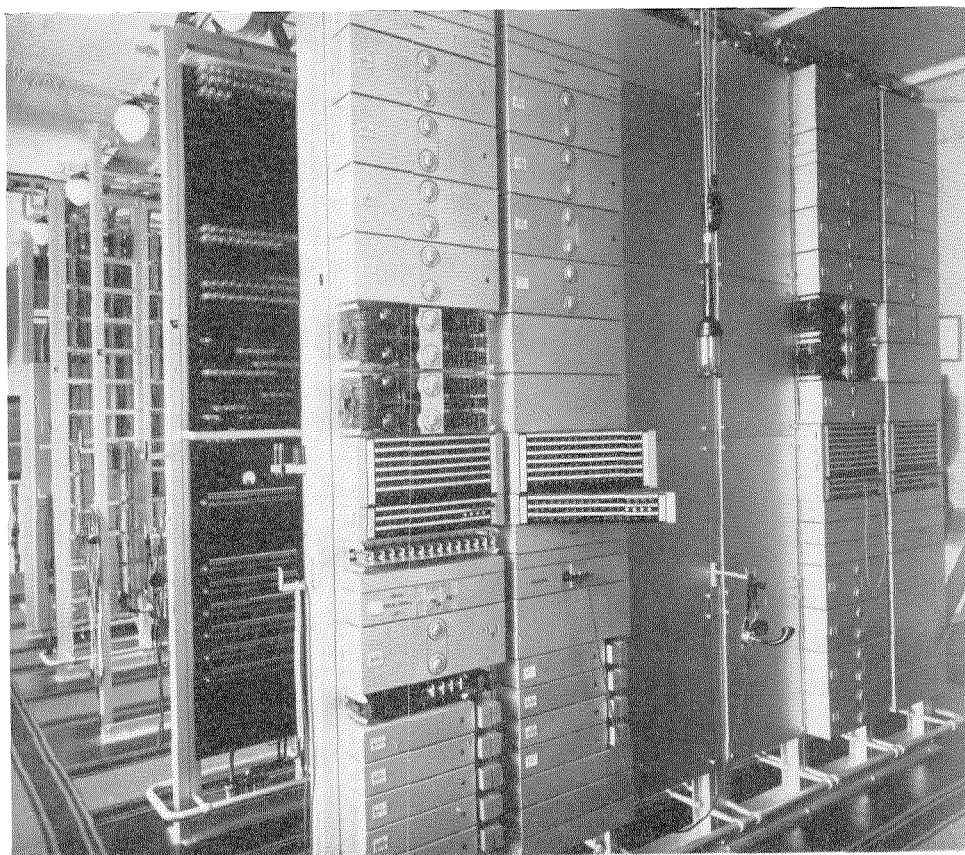

Figure 1—Repeater Bays on Site.

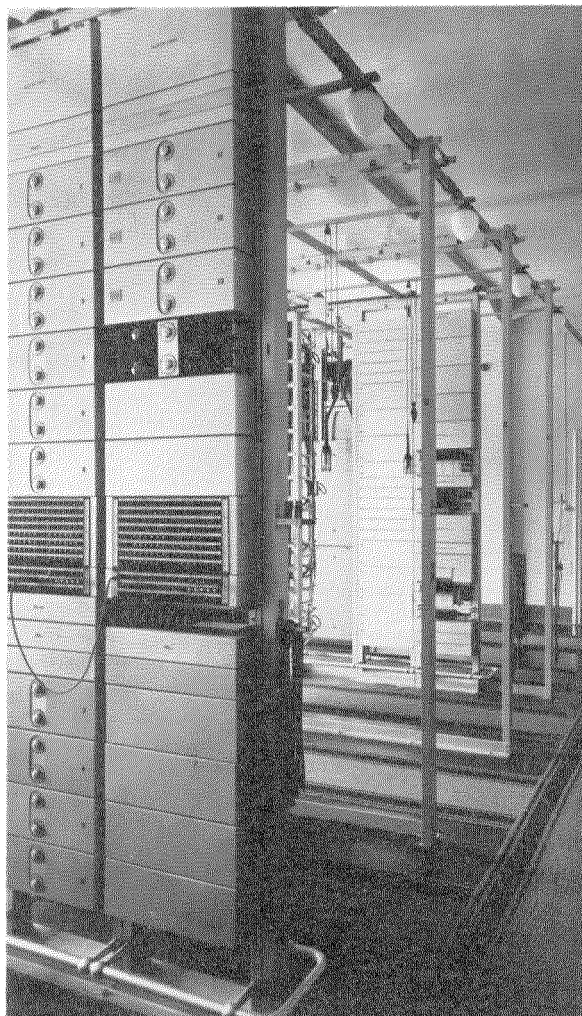

Figure 2—Typical Small Installation Showing Skeleton Framework.

equipment is considerably easier to handle during manufacture and installation.

The general outstanding features of the complete equipment are best illustrated by a few views of actual installations which have now been completed. Fig. 1 shows a number of combined bays of 2-wire repeaters and 20 cycle ringers erected on site. A notable feature is the improvement in lighting conditions brought about by the use of aluminium finish; this finish is now standard, but it should be noted that the equipment has also been supplied with black or grey finish in order to meet the desire of certain Administrations to maintain a uniform finish in extending a station where the old type apparatus has been installed initially.

Fig. 2 shows another view of the interior of a new station. In the foreground are two bays of repeaters and it is interesting to note that in this rather small installation the rear of these particular bays is equipped with voice frequency ringers. The illustration also shows the skeleton framework erected when the station is built in order to facilitate the work of future extension by means of unit type bays and also to support the cable racks, lighting fixtures, etc.

A typical view showing, on the left, the centralized battery supply bay with fuses equipped on the lower half and the resistance lamps above them, is given in Fig. 3. The concentration of a large number of lamps in a small space is well illustrated. On the right are the transmission test bays incorporating the measuring set, oscillator, grid circulating circuit, telephone panel, filament control panel, etc., while, on the extreme right, is a single bay with terminating sets for 4-wire circuits.

The improvement brought about in the appearance of a repeating coil and network bay, due to the provision of covers, is depicted in Fig. 4. On the left of this view may be seen a modern unit bay type of distributing frame.

Figs. 1, 2, 3, and 4 illustrate new type equipment installed for the Italian Administration in Sicily.

Figs. 5, 6, and 7 show unit type bays equipped with 4-wire repeaters, voice frequency ringers, and 2-wire repeaters, respectively. These views show the clean, neat appearance of typical bays constituting the new type of equipment. The last-mentioned bay again appears in Fig. 8, where it is shown with a number of dust covers removed to illustrate the manner in which the wiring is carried out. These bays are, of course, normally equipped with panels on both the front and rear of the framework but, in the event of a bay being required with one-half of its full complement of apparatus, the side not equipped is fitted with large flat steel covers, thus preserving the orderly appearance of the assembly.

Another point of interest may be noted in Fig. 1, where the method of hinging the jack field at the left hand side is shown. This permits easy access to the wiring of all jacks and keys.

Experience with repeater and voice frequency telegraph equipment has proved the success of the new form of construction from all points of view.

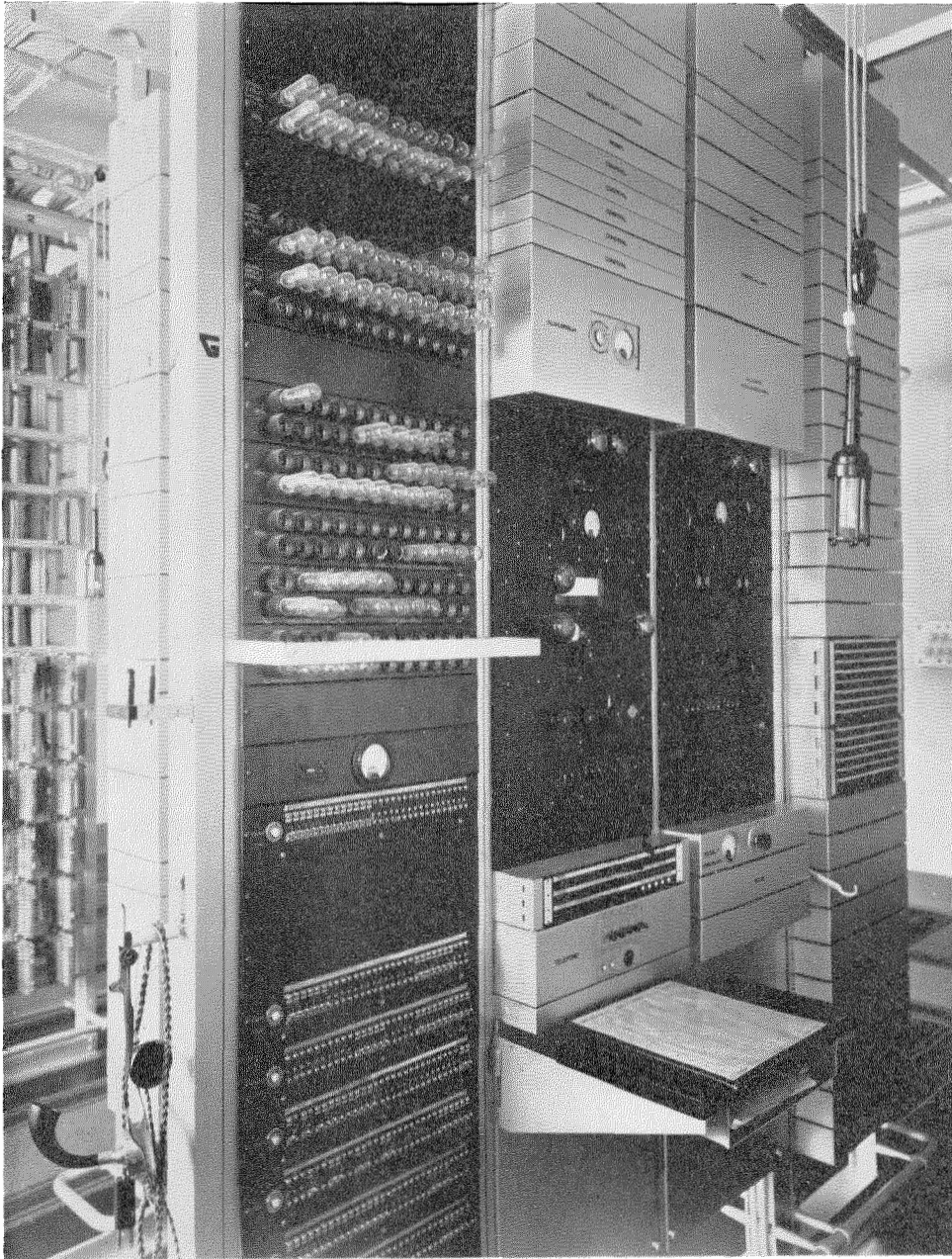

Figure 3—Battery Supply and Testing Bays.

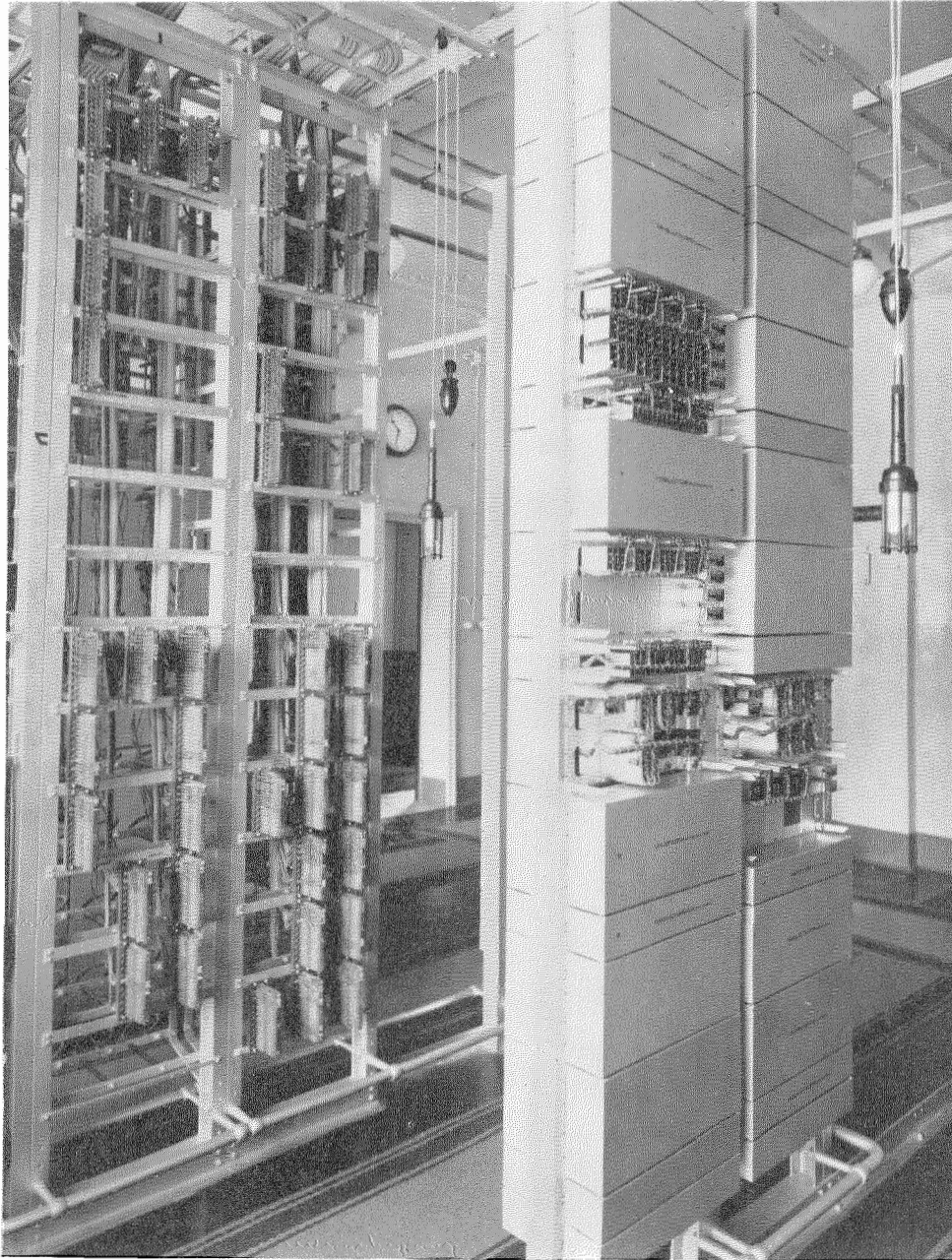

Figure 4—Repeating Coil Bays and Distributing Frame.

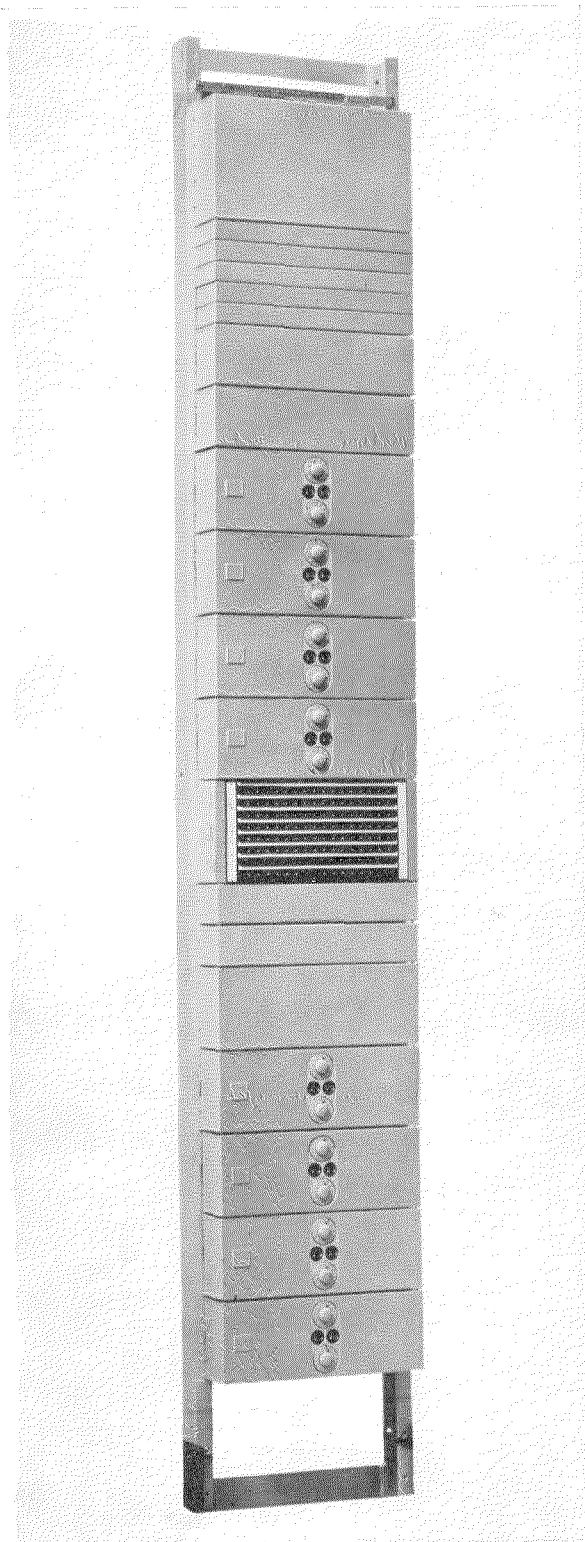

Figure 5—4-Wire Repeater Bay.

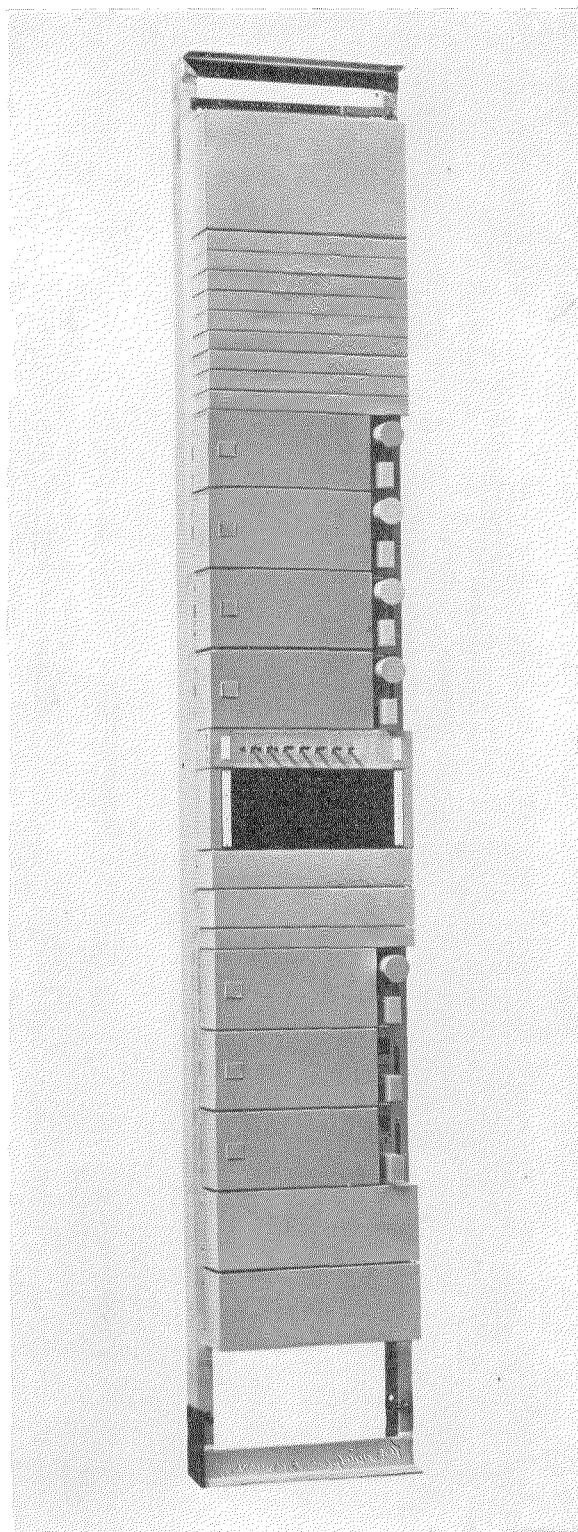

Figure 6—500 Cycle Ringer Bay.

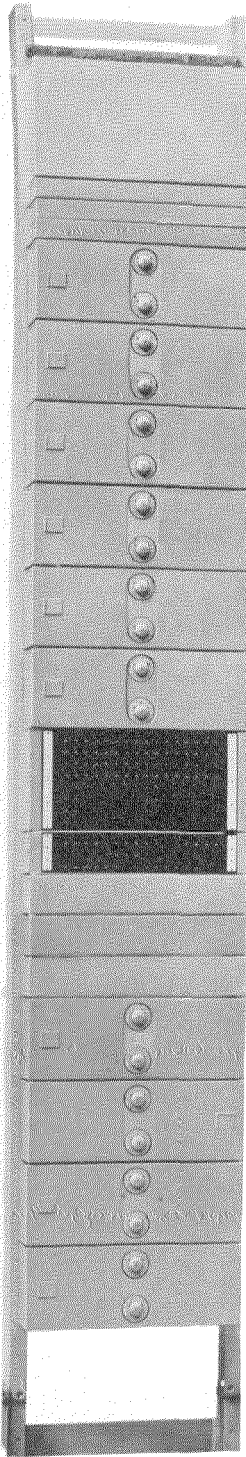

Figure 7—2-Wire Repeater Bay.

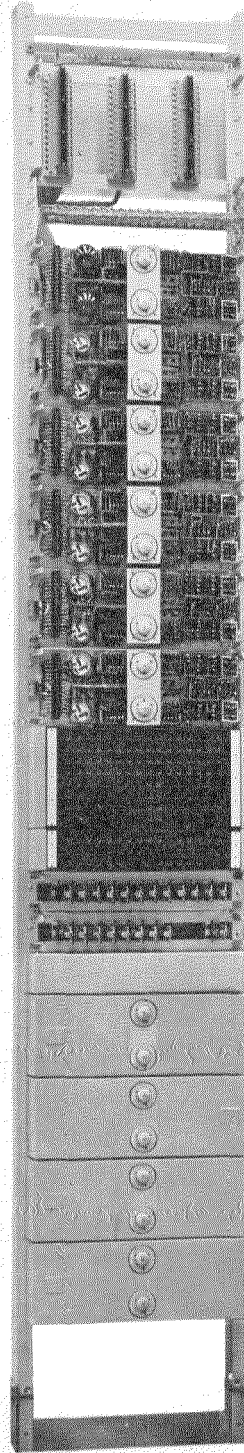

Figure 8—2-Wire Repeater Bay Showing Some Covers Removed.

Esterified Fibrous Insulating Materials

By A. A. NEW, M.Sc.

Standard Telephones and Cables, Limited

PART II

In Part I of this paper a general survey of the application of fibrous materials to electrical insulation and of the improvement from an electrical point of view produced in cellulosic materials by acetylation was given. In the present part the practical details of the manufacture, application, and testing of those acetylated cellulosic fibrous materials which are now in commercial use have been treated more fully, and a short description of modern ideas on the fine structure of cellulosic materials added. The final part (Part III) will deal with the flameproofing of textiles and its effect on insulation resistance and corrosion, especially with reference to materials of high insulation resistance like Cotopa; and particulars will be given of several recently developed esterified fibrous insulating materials of electrical interest.*

PRACTICAL details of the manufacture, application, and testing of Esterified Fibrous Insulating Materials, together with a description of the microscopic and submicroscopic structure of cellulose and its compounds, are mainly dealt with in this part of the paper. For convenience, the subject is handled under the following sections:**

- (1) Manufacture of *Cotopa*,
- (2) Production of coloured *Cotopa*,
- (3) Applications of *Cotopa* yarn in electrical manufacture,
- (4) Acetylated loose cotton, acetylated cotton tape, and acetylated paper,
- (5) Factors governing the insulation resistance value of *Cotopa*,
- (6) Structure of cellulose and its compounds with reference to their insulation resistance,
- (7) Chemical analysis of *Cotopa*,
- (8) Measurement of insulation resistance of textiles,
- (9) Routine testing of *Cotopa*.

1. Manufacture of *Cotopa*

The process by which *Cotopa* is made is broadly as follows: The raw cotton to be ester-

**Electrical Communication*, January, 1935.

**When referring to laboratory type of work the metric system has been employed throughout but, when referring to commercial practice, the figures have been expressed in yards, pounds, etc., followed by the approximate metric equivalent in brackets. In some cases, however, metric measures are used universally in practice in the bleaching and dyeing industries and one or two instances of this occur in sections 1 and 2. When referring to yarns the English Cotton Count (based on the number of 840 yard hanks of the yarn required to weigh one pound) is given first, followed by the approximate equivalent in the International Metric Count (based on the number of metres of the yarn required to weigh 1 gram).

fied is cleaned and purified by kier boiling (i.e., boiling in a particular type of enclosed vessel in which the air space, when loaded, is reduced to a minimum) for about 10 hours in a 1 per cent caustic soda solution under a minimum pressure of 20 lbs. per square inch (140 Kg. per square decimeter) followed by immersion in a bleaching powder or sodium hypochlorite solution, containing not more than 2-3 grams of available chlorine per litre, and then in one of very weak hydrochloric acid, which releases the chlorine from the bleaching compound. This free chlorine bleaches out all the non-cellulosic impurities in the cotton and, finally, a washing process completes the preliminary purification of the cotton.

The cotton yarn in a suitable form, such as that of loose cops or hanks, is then immersed in a bath comprising acetic anhydride, a dehydrating catalyst, and glacial acetic acid as a diluent, for a time sufficient to convert the cellulose present into a partially acetylated derivative showing on analysis a combined acetic acid content of 25% to 30%, after which the esterified product is carefully washed with water until all traces of the reagents have disappeared. An acetylation bath in which the proportions are roughly

15% acetic anhydride,
5% anhydrous zinc chloride, and
80% glacial acetic acid,

has been found suitable and takes about 15 hours to convert the fibres to the monoacetate stage at 40° C. The esterified material is then taken out of the bath, and after removal of

excess liquor it is put through a number of successive washing processes to remove all traces of chemicals used in the acetylation process.

In order to get the best results, an after-treatment subsequent to the final washing is desirable, and it may consist of drying for several hours at 100-110° C during which (according to Rheiner¹) the fibres completely lose all ability to swell in water and to take up direct dyes from a dyebath; and, most important from the electrical point of view, their insulation resistance properties are increased. An even more effective method of attaining the same end is to steam the esterified yarns under high pressure for a short period.

With an excess of acetic anhydride the reaction steadily gains speed and if left too long will produce heavy swelling of the fibre, acetylation to triacetate, and solution of the latter in the acetylation liquor. Fig. 1, however, shows the progress of the reaction when a more suitable amount of acetic anhydride is used.¹

Increasing the temperature of acetylation increases the speed of the process, but also leads to unevenness and premature production of the triacetate in the outer layers and its solution in the acetylating bath. A lower temperature slows the process down, and reduces the output.

Since acetic acid and particularly acetic anhydride are distinctly unpleasant in the vapour form, having an irritant action on the nose and eyes, special precautions must be taken in carrying out this process.

2. Production of Coloured *Cotopa*

Coloured *Cotopas* can be manufactured in two very different ways:

- (1) By dyeing directly with disperse colours such as are used for dyeing cellulose acetate silk,
- (2) By acetylating cottons which have been dyed previously.

1. DIRECT DYEING OF COTOPA

When dyeing with disperse colours the Artisil Direct series are particularly suitable.

For light shades the dyebath is prepared with an addition of 2-3 grams and, for dark shades, 1-2 grams of neutral soap per litre. The dyestuff is first dissolved in a hot soap solution and is

¹For all numbered references, see list at end of paper.

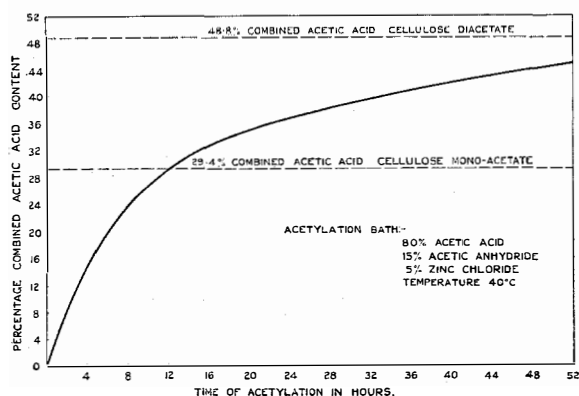

Figure 1—Relation of Combined Acetic Acid Content to Time of Acetylation.

then added through a fine sieve to the dyebath. The *Cotopa*, previously wetted out, is entered into the lukewarm dyebath and the temperature is then raised slowly to 75°–80° C (165°–175° F). To ensure satisfactory penetration of the colour, the material should be kept in the dyebath at least one hour. In order to remove traces of soap, the material must be thoroughly washed with several changes of soft water when the material is subsequently intended for use for electrical purposes. This dyeing process for *Cotopa* is patented² but is available to all users of *Cotopa*. A full range of shades of good fastness to light and washing is available in the group of dyestuff mentioned.

2. ACETYLATION OF DYED COTONS

The greater part of coloured *Cotopas* used for electrical purposes are produced by acetylating in the ordinary manner cottons which have already been dyed by one of the standard methods suitable for this fibre.³

The choice of dye to be used depends on the class to which it belongs. Cotton can be dyed satisfactorily with several classes of dyestuffs including substantive colours, diazotised or developed colours, basic colours, sulphide colours, vat colours, dyestuffs produced on the fibre, and mordant colours, and only one of these as a class is definitely unsuitable for subsequent acetylation, namely, the basic colours which are more or less completely stripped by the acid in the acetylating bath. This would seem to leave an extremely wide range of choice but the reverse is unfor-

tunately the case; the great majority of dyestuffs being either partially stripped in the acetylation bath or being considerably changed in shade, i.e., being made either duller or lighter. However, by careful empirical selection of dyestuffs, a full range of completely satisfactory colours has been found, consisting mainly of vat and substantive colours.

An interesting and unexpected result of the acetylation of cotton dyed with substantive dyes (direct cotton colours) is that these colours which normally are not very fast to washing, with the corresponding bad feature that cotton dyed with them easily stains white cotton when wet, are thereby rendered nearly as fast to washing and staining as the more expensive vat dyestuffs.

3. Applications of *Cotopa* Yarn in Electrical Manufacture

As *Cotopa* is such a recent development in the electrical field it can easily be understood that the whole of its possibilities are not yet realised in practice, but the following gives an idea of the extent to which it is being used in the various factories associated with the International Standard Electric Corporation:

- (a) Cords—in lapped and braided form,
- (b) Switchplate Wire—as in (a),
- (c) Switchboard Cable—in conjunction with cotton or wool.

Other applications are in process of development but are not yet in commercial production.

Among Administrations, the British Post Office already permits the use of *Cotopa* in all cases in which artificial silk is specified. British cablemakers in general are availing themselves of this permission to a very considerable extent.

It should be noted that the uses and application of *Cotopa* in the electrical field thus far have been restricted to the coarser counts. The finer counts (1/100's and upwards) have not been commercially applied to fine wires. Natural silk at present occupies a prominent position in this section of the field, but in the near future it will be strongly challenged by *Cotopa*. So far, however, the choice has been mainly between *Cotopa* and Artificial Silk.

It may be useful here to anticipate a later section and to indicate one aspect of the economics of the subject. References have already

been made to 29.4% combined acetic acid (the "monoacetate" stage) and to the band of 25% to 30% combined acetic acid, but it must be realised that increase of combined acetic acid content increases the cost of the acetylated yarn. One of the interesting points about this new method of forming high grade insulation by chemical action is that the quality obtained can be controlled on an economic basis. For normal purposes in which, say, artificial silk has proved entirely satisfactory in the past, the combined acetic acid content of the acetylated yarn can be kept down to a point (26% to 27% in general) at which economic advantage is obtained. If, however, high insulation resistance is the main feature required, the combined acetic acid content can be pushed up at increased cost to obtain the desired value. Combined acetic acid content is, of course, not the only governing factor in respect of insulation resistance, and more will be said about other factors hereinafter.

It should be recognised that, since the demand for *Cotopa* is relatively small at present, the material has obviously not reached its basic economic cost. As the demand increases, production costs should decrease and thus supply the electrical industry with cheaper and/or better insulation.

MANUFACTURING DETAILS

In practically all respects the running properties of *Cotopa* are identical with those of the corresponding counts of cotton, so that no fresh experience is required to deal with this material in the shops. Its covering power is substantially the same as cotton of the corresponding count. A comparison of its covering power with that of acetate silk is more difficult to express owing to the different systems of counts employed for the two materials, but it can be stated quite definitely that employing the appropriate counts, it costs appreciably less to obtain the same insulation resistance figures using *Cotopa* than it does when using acetate silk.

While *Cotopa* is outstanding as an insulating material for purposes where a drying process is not used, it should be pointed out that it is particularly resistant to the action of heat, and will stand higher temperatures than cotton or acetate silk without loss of strength. A sample of *Cotopa* heated for 45 hours at 150° C showed no loss in

tensile strength. The burning properties are much the same as cotton, but this will be dealt with more fully in Part III.

In soldering operations, artificial silk insulation is liable to melt and shrivel away if accidental contact is made with a soldering iron. *Cotopa*, however, has a higher scorching temperature than cotton and is uninjured by such contacts, provided, of course, that they are of short duration.

4. *Acetylated Loose Cotton, Acetylated Cotton Tape, and Acetylated Paper*

The same broad principles hold with regard to the preparation and properties of the above materials as for yarns, but there are various differences in detail due to their mechanical properties.

Loose cotton is acetylated in double walled vessels similar in principle to the well known Obermaier dyeing machines for loose fibres, in which the mass of fibres is held in a central container, the walls of which are perforated and up the centre of which runs a pipe also having numerous perforations. A pump then continuously circulates the liquor by sucking it from the outer vessel and forcing it through the perforation of the central pipe into the cotton. When the acetylation is complete, the acetylating liquor is drained off and the acetylated cotton washed by circulating numerous successive lots of water until acetic acid can no longer be detected in the wash water.

For cotton tape (as for all cotton fabrics) there are two possible methods, namely, to weave the tape from acetylated cotton yarn or to acetylate the tape directly. For commercial reasons the second of these is preferable and cotton tapes are acetylated in a similar manner to cotton yarn. As in the case of the esterification of most sheet materials, the tape is distorted slightly by the process, but this difficulty has been satisfactorily overcome by subsequently calendering the acetylated tape.

Wood pulp paper of the type largely used for insulating cables, coils, etc., or for bakelised paper insulation can be acetylated in a relatively simple manner, although certain definite precautions have to be taken to avoid distortion and to obtain a commercially economic process. Owing

to the low price of paper compared with cotton yarn, the effect of the additional cost of the acetylation process tends to restrict the number of economic applications. Reference to the remarkable effects illustrated in Fig. 4, Part I, suggests, however, that it will prove to be of considerable value wherever exposure to the atmosphere is inevitable and particularly where the total cost of the insulation is low compared with the cost of the apparatus involved.

The properties of these materials are changed by the acetylation process in much the same way as cotton yarns, namely, the moisture content is much lower and the insulation resistance at a given relative humidity very many times greater than the corresponding values for the original unacetylated materials.

As regards their uses, these materials are such a recent development that the full range of their applications is not yet known but a few of the more obvious ones are as follows:

Acetylated loose cotton or paper pulp is employed as "fillers" for electrical solid insulating materials, e.g., in connection with polymerised styrene joints for high tension cable.

Acetylated cotton tapes are used for binding power cable joints and terminations in place of linen tape.

Acetylated cable paper (0.0025 inch–0.010 inch thickness) (0.065 mm.–0.25 mm.) can be used to replace natural or artificial silk on conductors which will not be subjected to much mechanical bending. It can also be used as insulation for special types of power cable and for binding power cable joints and terminations, though naturally having less tensile strength and resistance to tearing for this latter purpose than the esterified cotton tapes referred to above. Further, it can be used as a basis for many forms of flexible sheet insulating materials replacing empire cloth, varnished papers, etc., such as are used for separating transformer windings and similar purposes.

5. *Factors Governing the Insulation Resistance Value of Cotopa*

DEGREE OF ACETYLATION

It has already been shown in Fig. 6, Part I, how the moisture content of cotton at a given relative humidity is reduced by the acetylation

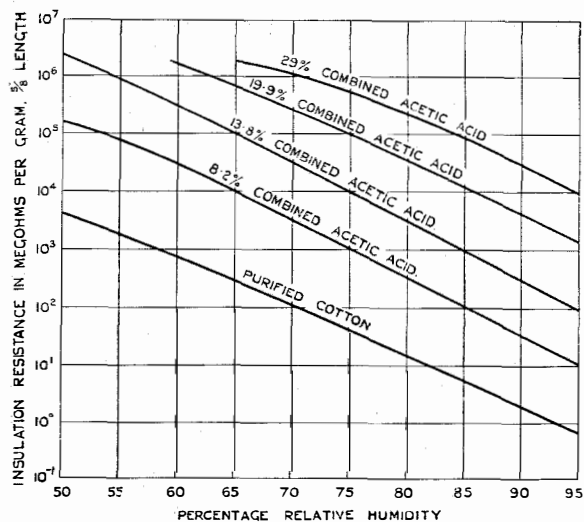

Figure 2—Relation of Insulation Resistance with Increasing Degrees of Acetylation to Relative Humidity.

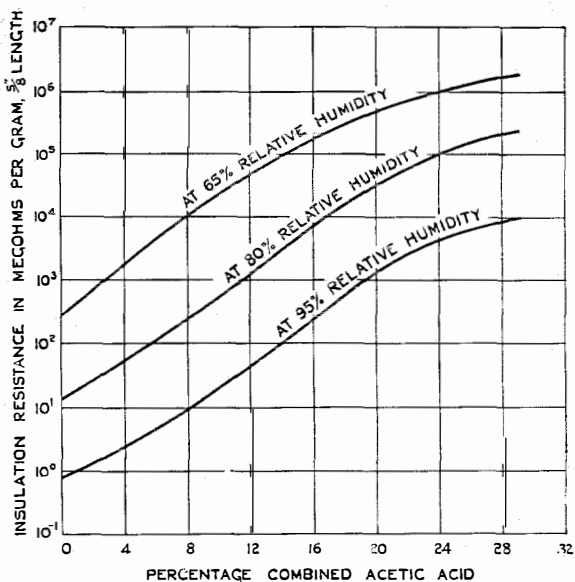

Figure 3—Relation of Insulation Resistance at Different Relative Humidities to Percentage of Combined Acetic Acid.

process. The corresponding steady increase in insulation resistance with increasing degree of acetylation is shown graphically in Figs. 2 and 3. These curves represent early work on this subject to establish general principles, and slightly better figures are now obtainable in the case of the 29-30% combined acetic acid acetylated cottons, such as the curve for *Cotopa* shown in Fig. 3 of Part I. The curves for moisture content (Fig. 6, Part I), and insulation resistance (Figs. 2 and 3 in this Part) are based on samples prepared in a slightly different manner and hence, while being

generally comparable, are not exactly so. The reason for the adoption of approximately 26% combined acetic acid content for normal commercial yarn has been discussed earlier in this article.

ELECTROLYTE CONTENT

The insulation resistance of *Cotopa* is lowered by the presence of electrolytic material in just the same manner as cotton or natural silk; hence, a thorough washing process is always employed after acetylation when the material is made for electrical purposes.

EVENNESS OF ACETYLATION

It is desirable that the degree of acetylation be uniform throughout the fibre as well as that the mean combined acetic acid content of the sample of yarn be of the required value; for, if there are any unacetylated portions of fibres (or portions acetylated to a lower degree), these would form a network of low resistance paths, perhaps not actually touching each other but nevertheless virtually short-circuiting portions of the good parts of the fibres and hence, lead to low insulation resistance values. The process details employed in the manufacture of *Cotopa* for electrical purposes are such that a perfectly even acetylation takes place. The method of testing this is given in detail later.

PREVIOUS HISTORY OF SAMPLE

Just as with all other textiles, a higher insulation resistance figure is obtained when *Cotopa* passes to the test humidity from a lower rather than from a higher humidity, due to the moisture content on the absorption curve always being less than on the desorption curve, as shown in Fig. 19.

EFFECT OF DYEING

The molecules of dyestuffs, when considered as electrolytes, are so large as to have practically no effect on the insulation resistance of a textile. As the substantive dyestuffs are now believed to be absorbed on the faces of the "crystallites" or "micelles" of cotton or *Cotopa*, it might be expected that they would help to block up the conducting water paths to some extent. The effect, however, if it exists, is so small compared with other factors, such as varying electrolyte content, that it has not thus far been detected.

Although the dyestuffs are comparatively without effect, the same is not true of the elec-

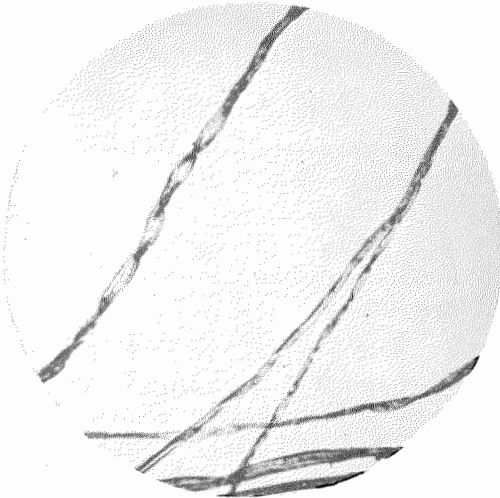

Figure 4—Untreated Cotton Fibres (Magnification 100 X).

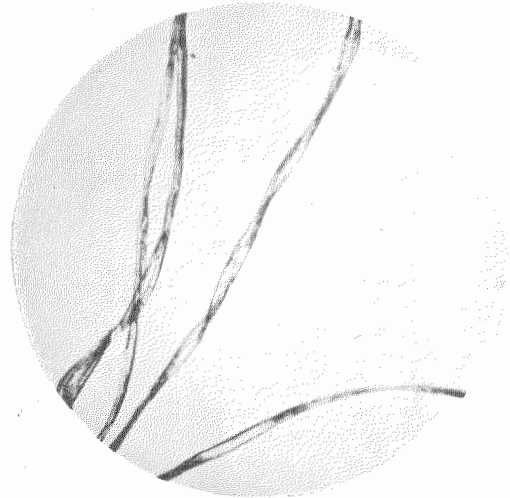

Figure 5—Cotopa Fibres (Magnification 100 X).



Figure 6—Part of a Cotton Fibre Showing Spiral Markings (Magnification 1000 X).



Figure 7—Part of a Cotopa Fibre. The Lattice-Like Appearance is Due to Two Sets of Spiral Markings Being Seen at the Same Time (Magnification 1000 X).

trolytic materials used as assistants in the dyeing processes and special care has to be exercised in washing coloured *Cotopa* in order to obtain the same insulating value that would be given by undyed material acetylated to the same degree.

6. Structure of Cellulose and Its Compounds With Reference to Their Resistance

Up to this point in this paper, a very simple

idea of cellulose has been employed—namely, that it consists of aggregates of the group

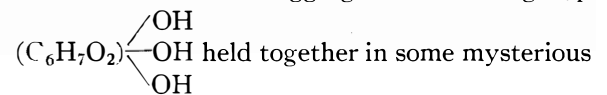

Until about ten years ago this was practically all that was known with certainty about its structure. Recently, however, there has been much

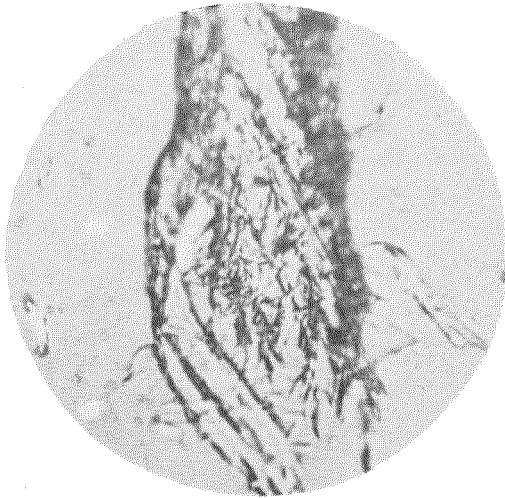

Figure 8—End of a Heavily Beaten Cotton Fibre, Showing Separation into Fibrillae (Magnification 1000 \times).



Figure 9—Coniferous Wood Pulp Fibres from Cable Paper (Magnification 100 \times).

activity in this field, and with such good results that the main outlines of the structure of cellulose are now known with certainty and it is possible to make some shrewd guesses at the smaller details.

The four main methods of attack have been along the following lines: (a) Microscopic, (b) By orthodox chemical methods, (c) By X-ray methods, and (d) By viscosity methods. It is not desirable here to go into details of the methods used or the reasoning employed, and only the outlines of the conclusions arrived at will be given.

(a) *Microscopic Methods.* To the naked eye cotton consists of white fibres measuring from 20-50 millimetres in length, depending on the species of plant from which it has come. Under a low power microscope (Figs. 4 and 5) the fibres are seen to consist of flattened transparent ribbons, with a curious twisted appearance. The white appearance of cotton when seen in the mass is merely the result of irregular light reflection from the numerous surfaces presented by the fibres. The cotton fibre is formed by the plant as a hollow cylinder but, on drying in the air as the boll opens, it becomes flattened and also assumes the twisted appearance referred to

above. As long ago as 1858, a botanist named Nägeli suggested that cellulose in all forms had a micellar structure of sub-microscopic dimensions.

With a greater magnification (Figs. 6 and 7) it is possible to discern parallel spiral markings on the fibre⁴ and if the fibre is torn apart or heavily beaten, the ends separate into numerous minute fibrils (Fig. 8.)

The first proof of the presence of daily growth rings in cotton fibres was given by Balls⁵ using the viscose reaction. In cross-section the markings are seen as rings, but in the entire fibre they appear as a number of fine, evenly spaced lines parallel to the outline. Mature hairs show about twenty-five rings corresponding to the twenty-five days' growth during which thickening is laid down in a cotton hair. The cessation of growth that takes place during the heat of the day is supposed to account for the alternation of growth and no growth that gives rise to the rings.

The cotton fibre is transparent under the ordinary microscope, but shows turbidity under the ultramicroscope; indicating submicroscopic structure. Treatment with sulphuric acid of 1.70 specific gravity causes the fibre to swell and ultimately to pass into solution. In the swollen

state the fibre shows a distinct structure which has been photographed by Harrison⁶. Since the acid acts in the direction of solution and not of coagulation, Harrison is of the opinion that the structure of the swollen fibre is an extension of that of the original fibre, this extension allowing the structure to be resolved.

Although the cotton fibre consists throughout of cellulose, there is a difference between the outer wall of the fibre, or cuticle, and the inner portions of the fibre. This difference of structure is probably colloidal in nature, rather than chemical. This is shown clearly by the greater resistance of the cuticle to solvents, such as ammoniacal copper oxide, which causes the fibre to assume a beaded appearance, the cellulose of the wall swelling through the torn places in the cuticle.

So far, cotton cellulose only has been considered, a form which has been studied very thoroughly under the microscope. Other common forms of cellulose, all in a less pure form than cotton, are flax or linen, ramie, hemp, jute, and wood. Linen and ramie are but little used electrically, and while considerable quantities of hemp and jute are employed in electrical manufacture, they are used for their mechanical properties only and are of less interest in the present connection. Wood, however, in the form of wood pulp paper, is a widely used electrical insulating material, and much microscopic work has been done in observing and classifying the appearance of wood fibres from different sources. In general, the coniferous woods, which constitute, together with hemp, practically all the cable papers used in Europe, consist of flat somewhat irregular shaped ribbons about 2-4 millimetres long without twist (Fig. 9) and frequently have large circular or tooth shaped marks on them. Wood fibres, as well as flax, ramie, hemp, and jute have all been shown to possess a fibrillar structure like that of cotton.⁷

Most, if not all, cellulose fibres appear to be built up of a series of concentric shells of spiral fibrillae⁸, though the spirals do not necessarily run in the same direction in each successive layer.

(b) *Orihodox Chemical Methods.* The problem of how the units of glucose, into which cellulose can be completely converted by the action of acids, can be assembled in the cellulose molecule

to give an organised structure is one which has taxed the ingenuity of chemists for decades.

The broad general features of the chemistry of glucose and the other sugars were elucidated in the researches of Emil Fischer and others, who established their relationships, and effected their syntheses from the simplest materials. The outcome of these investigations was a recognition that glucose and its analogues may be formulated as penta-hydroxy-aldehydes or Ketones thus:

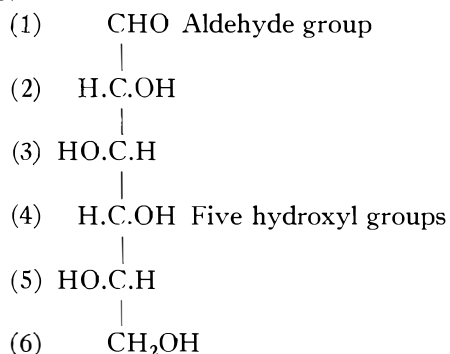

Haworth⁹ and a number of collaborators, in the last fourteen years, have carried out a detailed and fundamental reexamination of the constitution of glucose, as a result of which they proved that glucose should be represented constitutionally by a six-atom ring structure consisting of five carbon atoms and one oxygen atom in the ring, thus:

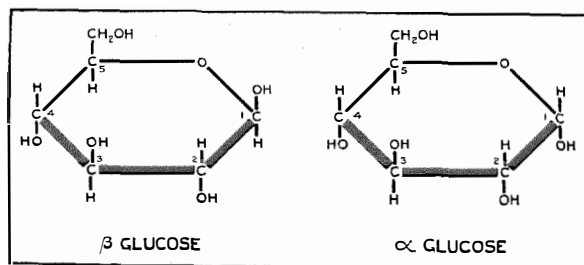

The only difference between these two forms is that of the relative position of the side chain oxygen with regard to the plane of the molecule, being below in the α form and above in the β form. The reducing carbon atom (which is potentially aldehydic) corresponding to the actual aldehyde group in Fischer's formula is numbered 1, as before.

It will be observed that in β -glucose one obtains the most symmetrical arrangement of

hydroxyl groups alternately above and below the central plane of the atoms constituting the ring. The atomic arrangement is shown in Fig. 10.

By various methods, cellulose can be broken down to compounds of greater complexity than glucose, called cellodextrins. The cellodextrins can be quantitatively converted to glucose, as is the case with cellulose itself, and amongst them have been recognised compounds containing four (cellotetrose), three (cellotriose), and most important of all, two (cellobiose) glucose groups.

Haworth⁹ and his collaborators have shown that this cellobiose molecule is the structural unit of cellulose, which consists of long chains of cellobiose units joined end to end, and cellobiose itself, they have shown to consist of two β -glucose units linked as shown below:

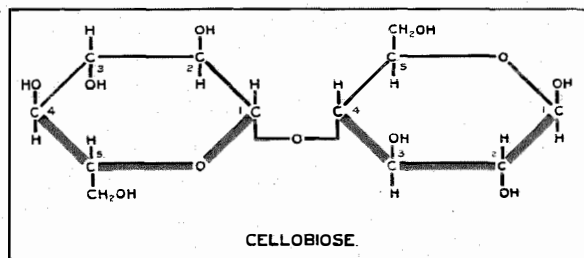

which will immediately be seen to consist of two β -glucose units joined together (with the elimination of a molecule of water), one being inverted with respect to the other. Fig. 11 shows the corresponding atomic arrangement.

Omitting the side groups for the sake of clearness, the main chains in cellulose can be represented thus:

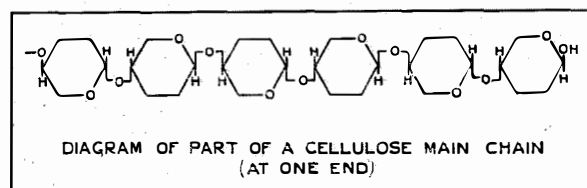

The full atomic arrangement of a small length of a cellulose main chain is shown in Fig. 12.

A determination of the length of these chains has been made in an ingenious manner by Haworth by forming derivatives of cellulose and then hydrolysing to obtain glucose derivatives when it can be seen that the end glucose unit in the cellulose chain will form a different glucose

derivative from all the others. By estimating the amount of this different compound he has found that the average chain length is of the order of 100-200 glucose units corresponding to a molecular weight of 30,000-40,000 (i.e., 30,000-40,000 times the weight of one hydrogen atom).

(c) *X-ray Methods.* If a fine beam of X-rays is passed through a fixed crystal such as Iceland spar (calcium carbonate) and the emergent beams photographed, a system of black spots is obtained due to the reflection of the X-rays at the different planes of the crystal. If a similar photograph is taken while the crystal is rotating about an axis perpendicular to the X-ray beam, another system of spots is obtained. If now the same treatment is applied to some finely powdered Iceland spar, a series of concentric rings is obtained, and the more finely the material is ground, the broader and more diffused these rings become, suggesting that if we could grind right down to molecular dimensions all traces of spots or rings would disappear.

The mathematical relation connecting the angle of reflection with the inter-layer distance has been worked out by Bragg and applied to cellulose and its derivatives by Sponser and Dore, Meyer, Mark¹⁰, and others, and to the animal fibres by Astbury¹¹.

The results of this work show that in cellulose there are long molecular chains parallel to each other and in the case of mercerised cotton parallel to the axis of the fibre, but in untreated cotton inclined at an angle to the axis of the fibre, consistent with their being placed spirally around it. They also show that the fibre substance is crystalline, being made of very long thin crystals in which the pattern repeats along the fibre axis at a distance of 10.3 A.U. (about 0.000,0001 cm.), which is just the length of two glucose residues. Measurement of the sizes and positions of the spots lead to the conclusion that the crystals in cellulose are at least 600 A.U. long, of the order of 50 A.U. thick, and the cross-sectional area occupied by each chain is about 33 square A.U. Therefore the chains must be well over 100 glucose residues long and the average number of chains per crystal somewhere about 50. A natural cotton hair is therefore built up of such "crystals" or "micelles", and every "crystal" of chains and every chain again built up of

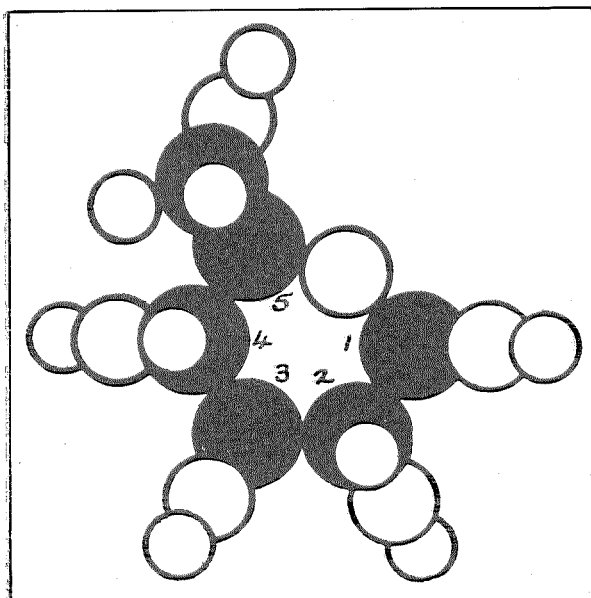

Figure 10—Atomic Arrangement of Glucose.

glucose units in a definite manner.*** This is indicated diagrammatically in Fig. 13 on a scale such that an ordinary yarn of cotton would have a diameter of the order of 100 metres.

(d) *Viscosity Methods.* By an elaborate study of the laws governing the viscosity of solutions of compounds of high molecular weight, Staudinger¹² has come to the conclusion that in solution cellulose and its derivatives consist of long molecular chains having a length of about 4,000 A.U. and a molecular weight of about 120,000. This is qualitatively in agreement with the ideas of the nature of the cellulose molecule determined by the other lines of study mentioned above, but assigns it a chain length of about 4-6 times greater.

CELLULOSE STRUCTURE AND INSULATION RESISTANCE

Having now obtained a rough picture of how cellulose fibres are built up, it is possible to consider how the ideas of the insulation resistance of textiles and the esterification processes are affected by it.

Reference has been made earlier in this paper to the fact that for practical purposes the whole of the conductance of a textile fibre resides in

***There is, however, no evidence from X-ray measurements to indicate that the "crystals" are very sharply defined like, for example, bricks in a wall. They also probably vary greatly in size.

the water contained in it, and that conductance is largely governed by the electrolyte content of the fibre, also that the moisture in a textile fibre is probably held in two or three different ways. As long ago as 1914, Evershed pointed out that the quantity of water present in insulating materials is far in excess of that which would be required to furnish the observed conductivity if the water were in the form of continuous filaments of uniform cross section¹³. It has been suggested that the conducting water paths in a textile consist of filaments having alternately expanded and constricted sections along their length, forming a regular space pattern whose elements have different dimensions for different textiles. The resistivity of the textile is then determined by the cross-sectional area of the narrowest parts of the path.¹⁴ It has also been suggested that some of the water is present in an isolated form which, of course, would have little or no effect on the conductivity of the fibre,¹⁵ and that the distribution of water is such as to tend to make the adsorption of ions at the inter-face between the aqueous electrolyte and the solid dielectric an appreciable factor in conduction.¹⁶ It has been realised for many years¹⁷ that water does not consist merely of H₂O, and it is highly probable that it consists of a mixture of three types of molecules:¹⁸ H₂O, (H₂O)₂ and (H₂O)₃ in equilibrium, possibly with the atoms linked together, thus:

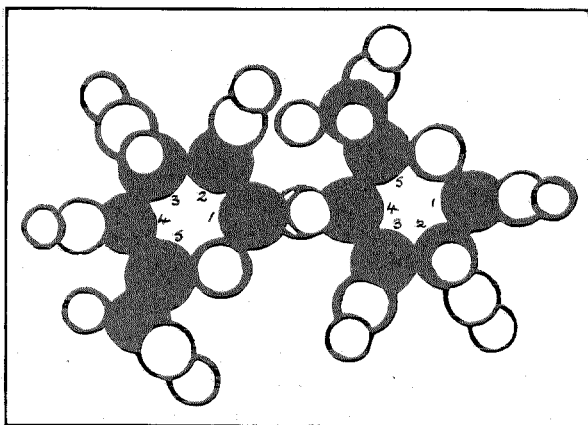
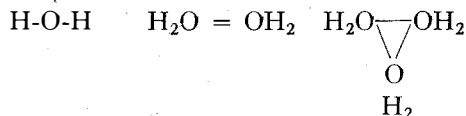

Figure 11—Atomic Arrangement of Cellobiose.

As water thus readily links up with itself it is not hard to visualise the adsorption of water by cellulose as a similar reversible linkage process between water molecules and the $-OH$ groups in the cellulose.

Speakman has shown that the intermicellar space in wool changes from 6 A.U. to 41 A.U. between 0 and 100% relative humidity, but this is of much too small an order to explain the resistance changes, and Marsh and Earp point out that it is very difficult to conceive of any channel in a wool fibre changing its dimensions at the rate required by the resistance phenomena, and suggest an "emptying" of the wider sections of the water channels as the moisture content diminishes, thus causing the resistance of the particular channels to become practically infinite. In connection with the above O'Sullivan² pointed out that, assuming the validity of the Kelvin equation in such cases, one can calculate the effective capillary radius of the pores from the vapour pressures of cotton of various moisture contents, obtaining values ranging from about 10 to 1,000 A.U.; and as most ions are hydrated and carry with them an atmosphere of water molecules, they would be expected to experience a resistance proportional to the viscosity of the liquid through which they migrate. In capillary tubes, the viscous hindrance is proportional to the fourth power of the radius, and if this relation holds down to radii of the values stated above, the electrical resistance might be expected to change 10^8 fold which is of the order required to account for the recorded variation of resistance with moisture content.

While the above upper limit of 1,000 A.U. for the channel radius is most probably too high, it seems probable that a combination of this effect with that of channels becoming ineffective electrically due to a portion being "emptied" is most likely to be the true explanation of the enormous variation of insulation resistance with moisture content. It is possible that the "emptied" portions will eventually be found to be those where the crystallites approach so close together that adsorption effects completely prevent the movement of ions even though there are still one or more layers of water molecules present in those portions of the channels.

Wet or dry textile fibres give just the same

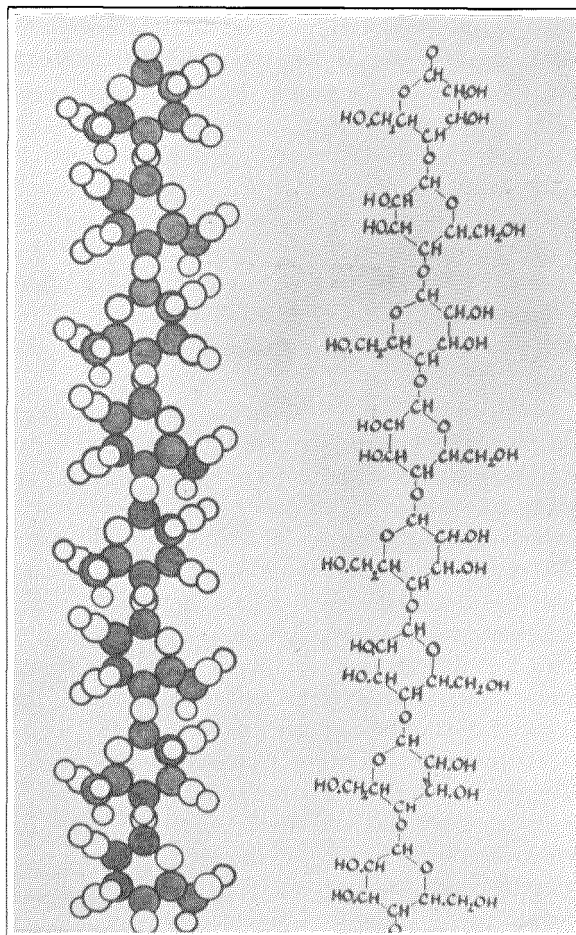

Figure 12—Atomic Arrangement and Conventional Formula of a Short Length of a Cellulose Main Chain.

X-ray photographs, thus indicating that the adsorbed water for the most part does not penetrate into the interior of the crystallites themselves, but lies between them and is distributed over their surface;¹¹ hence, it is highly probable that the conducting channels are the spaces between the micelles or crystallites and that very little conduction takes place through the interior of the micelles.

CELLULOSE STRUCTURE AND ESTERIFICATION

From the preceding description of cellulose structure it will be appreciated that the terms "monoacetate" and "diacetate" of cellulose must be used with due regard to the complicated structure of the fibre and not as indicative of an abrupt change in characteristics at 29.4% combined acetic acid content. It is preferable to employ the more non-committal "acetylated

cellulose of $- \%$ combined acetic acid content" and to be clear that this figure is merely the mean of a vast number of units which are not necessarily esterified to the same degree, even though the distribution of acetyl groups is regular throughout the fibre as far as can be determined by the microscopic methods referred to elsewhere in this paper. This point of view is supported by the lack of any sharp change in electrical or other properties at 29.4% combined acetic acid (i.e., "monoacetate") in a series of acetylated celluloses.

As the identity of $-OH$ groups in the cellulose complex is destroyed by esterification, it is clear that water molecules can no longer link themselves to them in the manner referred to above, and hence the degree of adsorption of water should be an inverse function of the degree of esterification. This is in accordance with practical observations over a wide range (see Fig. 6, Part I), although above about 35% combined acetic acid content, the effect appears to be reduced. Cellulose acetate silk (of 45-50% combined acetic acid content) is made by an entirely different process to that employed in making acetylated cottons and has a different structure, which accounts for its having a higher moisture content and lower insulation resistance than *Cotopa*, even though it has a higher combined acetic acid content than the latter.

7. Chemical Analysis of *Cotopa*

The chemical analysis of *Cotopa* involves two determinations: the amount of combined acetic acid or acetyl group, and the degree of evenness of the acetylation.

COMBINED ACETIC ACID CONTENT

Numerous methods are available for this determination, all depending on splitting up the combination of cellulose and acetic acid and measuring the amount of the latter liberated. One of the most suitable for this purpose is the following:

A representative sample hank of the *Cotopa* of about 1 gram is weighed in the dry condition, cut into approximately 12.5 mm. lengths and placed in a 250 millilitre conical flask, together with 100 millilitres of standard decinormal caustic potash solution, and boiled gently under a reflux condenser for two hours, after which the

solution is back-titrated, while still hot, with standard normal sulphuric acid from a microburette holding ten millilitres, using phenolphthalein as indicator. Since, under these conditions cotton itself gives a small positive figure, due presumably to part of the cellulose molecule hydrolysing to form traces of acid bodies, it is

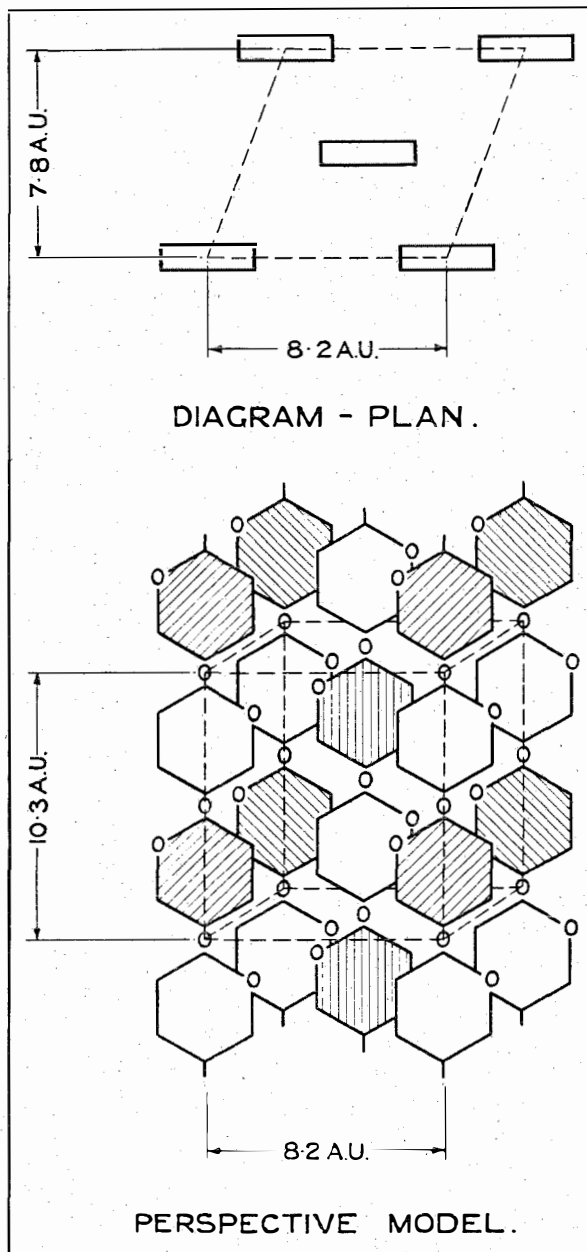
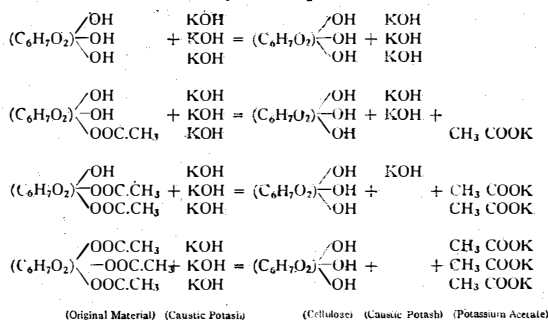

Figure 13—Diagram of Spatial Arrangement of Main Chains of Cellulose (For clearness the chains are drawn smaller in comparison with the space between them. The shading is shown in various ways to heighten the perspective, but does not imply anything more than that in each chain alternate units are reversed).

desirable to run a blank determination on a sample of cotton at the same time when a figure of the order of 0.5% is generally obtained.

The reactions may be represented thus:



depending on the amount of acetyl group in the molecule.

Thus if 1 gram of dry *Cotopa* were analysed as above and a back-titration of 5.02 ml. of, say, normal sulphuric acid obtained, the calculation would be as follows:

The amount of potash used up in saponification is equivalent to .299 gram acetic acid which is 29.9% of the original 1 gram of material taken. As 1 gram of cotton, under these conditions, would yield about 0.5% oxidic bodies (calculated as acetic acid) an allowance should be made for it by deducting $\frac{100 - 29.9 \times 0.5\%}{100}$ from this figure,

giving $29.9\% - 0.35\% = 29.55\%$ combined acetic acid.

A criticism often levelled at this mode of expressing the results is that the acetic acid is not formed until the acetylated cellulose is broken up and that the result of calculation should be expressed in terms of "acetyl group content" ($\text{CH}_3 \text{ CO}-$). This method is that most generally used, however, and anyone desiring to express his results in the other system has only to multiply the figures obtained in the above manner

by $\frac{43}{60}$.

The above method is suitable for white *Cotopas* and those dyed with vat colours. In the analysis of samples dyed with substantive colours sufficient of the dye often dissolves out to such an extent that it is impossible to see the end point of the titration. For such cases as this the following method, while less accurate than the above, is useful.

Take a 1 gram sample of *Cotopa* which has been

weighed in the dry state and boil for two hours with 20 millilitres of half normal alcoholic potassium hydroxide (0.028 gram KOH per ml.) under a reflux condenser. Back-titrate with normal alcoholic sulphuric acid (0.049 gram $\text{H}_2 \text{SO}_4$ per millilitre of ethyl alcohol) made up cold, using phenolphthalein as indicator. Probably a little ethyl sulphuric acid is formed, but this is decomposed later, in the titration, giving the quantitative amount of sulphuric acid. As the alkali absorbed in the textile diffuses out more slowly in alcoholic than in aqueous solution, the end point tends to repeat two or three times and hence it is necessary to boil the liquid two or three times just before the end point is reached, in order to get the last traces of alkali out of the textile.

DEGREE OF ACCURACY

The first method has a possible error of about $\pm 0.5\%$, and the second about $\pm 1.0\%$ in terms of acetic acid content. This is sufficient for most commercial work but, if a high degree of accuracy is required, the method of K. Hess²¹ is to be recommended, whereby a degree of accuracy of about $\pm 0.2\%$ can be obtained on either white or dyed *Cotopas*. It is, however, much longer and more tedious than the above mentioned methods.

These methods are all applicable to the analysis of acetylated paper, and also to cellulose acetate silk, provided the amounts of caustic potash used are increased.

EVENNESS OF ACETYLATION

The uniformity of the degree of acetylation of a spool or delivery can, of course, be checked by a number of combined acetic acid content determinations on small samples taken from various parts of the spool or delivery, but it is also possible to determine the degree of evenness of acetylation of the fibres comprising the material at any given point by making use of the difference in dyeing properties between cotton and esterified cotton. If a normal sample of *Cotopa* is dyed with 1-amino 2 methylanthraquinone or 1.4 diaminoanthraquinone in the normal manner for this class of colour quoted elsewhere in this paper, and then sectioned and examined under the microscope, the fibre will be seen to be coloured evenly¹ right through, as shown in Figs. 14 and 15. If, however, the acetylation is uneven, only the acetylated portion



Figure 14—Cross-Section of Cotopa Fibres Dyed with a Disperse Colour. Even Dyeing Indicates Even Acetylation. (Magnification of this figure approximately of the order of 600).



Figure 15—Cross-Section of Acetylated Mercerised Cotton Dyed with a Disperse Colour. Even Dyeing Indicates Even Acetylation. (Magnification of this figure approximately of the order of 600).



Figure 16—Cross-Section of an "Immunised" Cotton (Cellulose Benzoate) Dyed with a Disperse Colour. Only the Outer Ring is Coloured. (Magnification of this figure approximately of the order of 600).

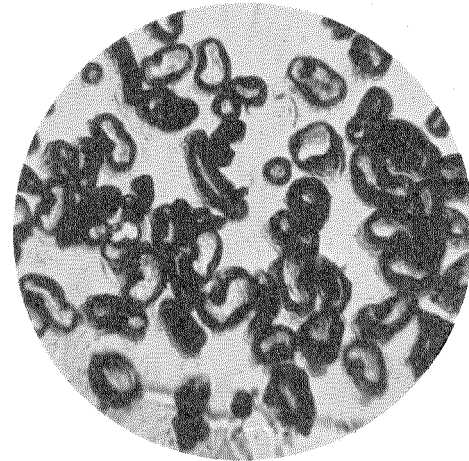

Figure 17—Cross-Section of Another "Immunised" Cotton Showing Heterogeneous Constitution of Fibre. (Magnification of this figure approximately of the order of 600).

will be coloured, giving the type of effect shown in Figs. 16 and 17, which is obtained by testing an "immunised" cotton in this way. The dyed ring can be plainly seen surrounding the light coloured centre in each case. In Fig. 16 the ring consists of cellulose benzoate and the centre of course is unchanged cellulose. In Fig. 17, in order

to get the maximum distinction for reproduction, the *o*.nitrotoluene sulphonic ester was formed and converted into an insoluble red dye by reducing, diazotising, and coupling with β naphthol. The dark coloured ring surrounding the centre of unchanged cellulose shows up very distinctly on sectioning.

8. Measurement of Insulation Resistance of Textiles

PREPARATION OF SAMPLES

The greater part of the work done in connection with esterified fibres has been carried out on yarn tested as such and on twisted pairs formed from wires insulated with one or more servings of the yarn to be tested.

In the case of yarn, a continuous thread is wound on to two brass posts separated $\frac{5}{8}$ inch (16 mm.) by means of two small clamps, the combination forming a unit which is rotated about its major axis. The thread is given a slight traversing movement by means of a threaded rod. A variable gear having ratios from 1-4 to 10-1 makes it possible to deal with a wide range of thread diameters, as well as those cases where a number of ends are laid together. The gear ratio is adjusted to produce a single layer of threads which just touch and do not overlap. Two stiff brass strips are then screwed on to each pillar to hold the threads in position and make good contact.

Twisted pairs have been made up by lapping .036 inch diameter tinned copper wire with one or more servings of the textile yarn to be tested, and pairing in a pairer as used for switchboard cable. In order to make these results comparable, all insulating and pairing operations on samples have been done on the same heads of the same machine and with the same pairing lay.

ELECTRODE HOLDERS

Reverting to the yarn samples, the electrodes are pushed into a special electrode holder shown in Fig. 18. This consists of a tin plated brass container with the two larger sides removable and having three valve sockets on top, the outer ones carrying the electrodes being insulated by ebonite, and the middle one being connected to the brass container which serves as a guard ring. The sides can be opened or closed by raising or lowering the movable shutters so that a sample can be conditioned at one humidity with the sides open, the shutters closed, and the sample transferred to some other vessel at a different humidity without being affected by the degree of humidity of the air through which it passes when being transferred from the one vessel to the other. For the sake of convenience, separate "dummy" shutters are used to replace the full

sized ones when the electrode holders are in position in the conditioning vessels. Reference will be made later to the necessity for sometimes protecting the textile sample from the intermediate atmosphere.

PRETREATMENT OF SAMPLES

In order to get an accurate comparison of the insulation resistance of a number of textile samples, it is necessary to pretreat each sample either by drying it to zero moisture content or exposing it to an atmosphere of 100% relative humidity. Appreciably higher figures are obtained by employing the first method of pretreatment, but the same relationship exists between the insulation values of any set of samples, whichever method is employed; it is only the absolute values which are changed, approximately in the same ratio. As predrying is more convenient than "presaturating," this method has been adopted as a convention in work on this subject,²² and all results quoted in this paper have been obtained after first predrying overnight in a desiccator over phosphorus pentoxide.

The reason for the above difference and, hence, for the precautions taken, is that the moisture regain of textiles in equilibrium with any atmosphere is dependent on the condition of the textile previous to its introduction into that atmosphere, the difference in the case of cotton amounts to 1-2% at ordinary humidities (50%-90% relative humidity) depending on whether the cotton starts from the wet or from the dry state.²³ It is the moisture content of the textile and not the relative humidity of the conditioning atmosphere which governs the insulation resistance of the textile. Fig. 19 shows this effect in graphical form, and Fig. 20 shows the effect on the insulation resistance¹⁴ of cotton threads.

It can now be seen why it is desirable in some cases to make use of the shutters on the electrode holders. If accurate figures are required at, say, 40% relative humidity, and a sample is dried to zero moisture content and then allowed to stand in the air of the room for a few minutes at perhaps 80% relative humidity during transference to the 40% R.H. vessel, errors may arise if the sample has been in the air long enough to take up more moisture than the equilibrium regain corresponding to 40% R.H. If the relative humidity of the

air of the room is lower than that of the test vessel, this precaution is unnecessary.

CONDITIONING VESSELS AND CONSTANT TEMPERATURE CABINET

The conditioning vessels (Fig. 21) are glass accumulator jars with accurately fitting flanged bakelite tops in which are cut holes into which the electrode holders accurately fit. Soft rubber seatings are provided where the bakelite top fits the glass and where the flanges of the holders rest on the bakelite top so as to seal up the vessel completely when in use. A small fan driven by a tiny electric motor circulates the air in the vessel.

The desired degree of humidity is produced by sulphuric acid solutions based on the relative humidity-specific gravity curves of Wilson.²⁴ After exposure of the samples to these humidities for 24 hours the rate of change of resistance with time is extremely slow and by this time the samples, in most cases, can be considered to be substantially in equilibrium with the surrounding atmosphere. There are, however, cases where a longer period is necessary, but for all cottons and cellulose derivatives 24 hours is sufficient.

The conditioning vessels are placed in an electrically-heated constant temperature cabinet in which the heat regulation is provided by a toluene thermoregulator and an Isenthal mercury switch, and the temperature of the air in the cabinet is kept constant to within $\pm 0.1^\circ$ C of the desired temperature by this means.

Two sets of double doors are provided at the front; in the left-hand inner one a small glass window is fitted to permit visual observation, and in the right-hand inner one a small hole is cut just big enough for the operator to insert his arm to change the leads. Accurately fitting wooden plugs are provided to fill these spaces when electrical measurements are not being made. The outer double doors are of stronger construction and also give additional heat insulation. A small pilot lamp wired in parallel with the galvanometer lamp provides illumination inside the cabinet when testing is being carried out, but its heat dissipation is insufficient to affect the temperature in the cabinet in a normal testing period.

The test leads are brought in through the back of the cabinet and terminate in a three

point plug, which fits the electrode holders. The leads are rubber insulated and have concentric wire screens connected to the centre plug and to the battery side of the galvanometer.

TEST SET

The test set used for most of this work is a straightforward direct deflection set using a high sensitivity Cambridge Instrument Company's galvanometer with a Universal shunt. The galvanometer is specially mounted in order to minimise vibration effects. Standardisation is effected by a standard megohm (checked against a National Physical Laboratory standardised megohm) which can be brought into circuit by moving the key, and leaks guarded against by mounting the megohm shunt key and galvanometer on metal plates connected to the battery side of the galvanometer. A schematic diagram of the set is shown in Fig. 22. With 500 volts pressure, as used in most of this work, a deflection of 5 mm. is obtained with a resistance of 1,000,000 megohms, and this has been taken as the limiting deflection on which to base results.

METHOD OF TEST

The sample is conditioned at the required humidity for 24 hours at 25° C and its resistance measured. In the majority of cases a steady reading is obtained (after the initial movement of the galvanometer spot) within about 30 seconds; but in cases where the sample has a high electrolyte content the value may change steadily, in which case the reading is taken as soon after the application of the voltage as possible, which is generally about 30 seconds. In some cases readings have been taken on an Evershed and Vignoles two-range "Megger" in order to get readings as soon as possible after application of the voltage.

MODE OF EXPRESSION OF RESULTS

When the readings are completed the portion of the textile sample which has been tested is carefully cut out with a razor blade, dried and weighed. The resistance is then divided by the weight of the sample in grams to give the resistance of the textile in megohms per gram, 16 millimetre ($\frac{5}{8}$ inch) test length which is the unit in which all the measurements in the present work have been expressed. The maximum amount of textile yarn it is desirable to employ

is about 0.4 gram, which is equivalent to 400,000 megohms/gram with the limiting deflection of 5 mm. referred to previously. Connecting six such samples in parallel enables readings corresponding to 2,400,000 megohms/gram to be made. It is estimated that for readings below 500,000 megohms the results for any one sample are correct to within $\pm 10\%$. Where the added varia-

tions found in good textile yarns have to be taken into account a variation of about $\pm 40\%$ on either side of the mean is the usual condition found on testing a large number of consecutive lengths of thread from the same spool.

9. Routine Testing of *Cotopa*

In the routine testing of *Cotopa* the following

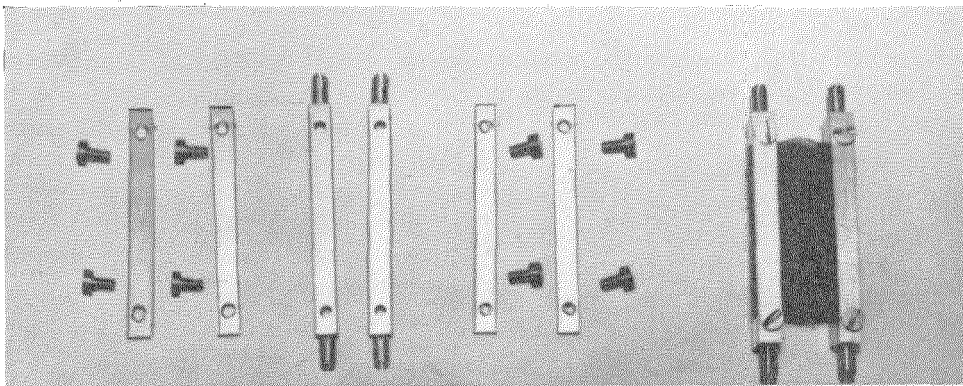
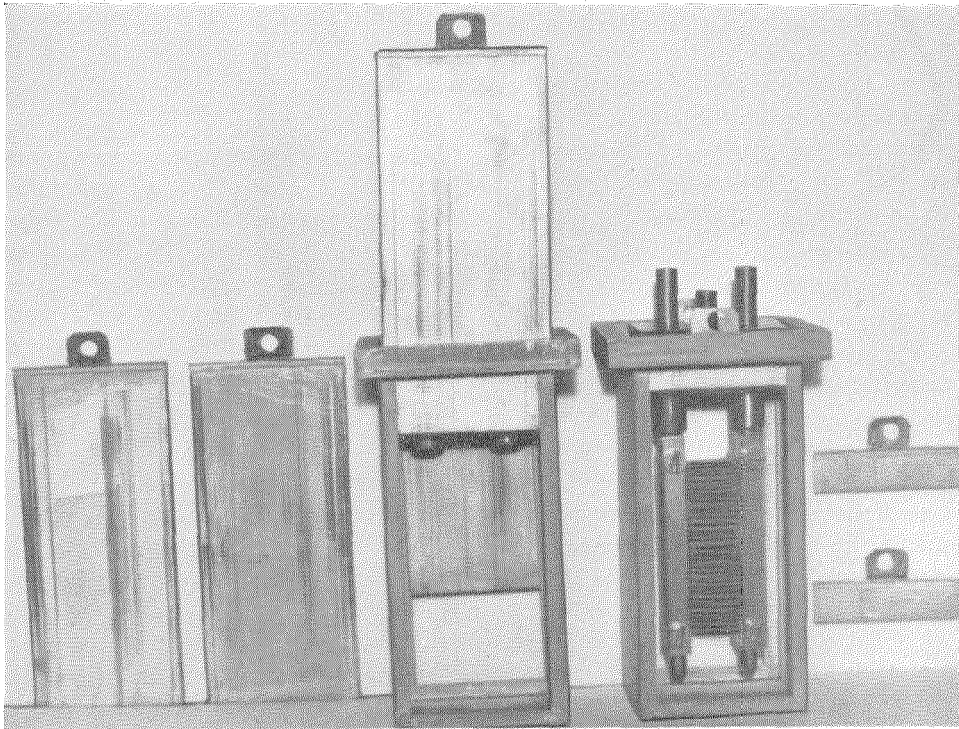

Figure 18—Above—Electrode Holders. Below—Electrodes for Textile Yarn Samples.

bread requirements should be fulfilled:

The material supplied must be thread or yarn made entirely from soft cotton fibres and subjected to the *Cotopa* acetylation process whereby the fibrous nature of the yarn is unaltered; the combined acetic acid content of the yarn about 25%–30%, and the insulation resistance raised to at least 100,000 megohms/gram at 80% relative humidity and 25° C, using 500 volts test voltage. It must also be of uniform diameter, quality, and twist, and be free from knots and other blemishes and also from injurious chemicals and loading materials.

It would be inappropriate in this paper to describe the test methods in full and, hence, only the following brief summaries of the methods employed in the routine testing of *Cotopa* at Standard Telephones and Cables Ltd., London, will be included.

MOISTURE CONTENT

This test is carried out with a Schopper electrically heated conditioning oven, which in principle consists of a strong balance in which the left-hand pan is replaced by a wire basket sufficiently large to hold several cheeses of *Cotopa* or cotton. This basket is surrounded by the electrically heated oven, the connection between the basket and the beam of the balance going through a small hole in the roof of the oven; a cover is provided to close this hole except at the moments when actual weighings are being made.

A number of cheeses are taken at random as soon as the packages are opened and placed in the wire basket and weighed. The oven is then heated up and kept at 110° C until the cheeses have dried out to constant weight (about 24 hours) which is noted and the moisture content calculated. The maximum amount allowable is 5% by weight of the dried *Cotopa* yarn.

COUNT AND YARDAGE

The English Cotton Count is defined as the number of hanks each of 840 yards that weigh 1 lb. (The International Meter Count is defined as the number of metres of yarn required to weigh one gram.)

In practice this determination is accomplished by measuring off accurately on a Goodbrand yarn winder 80 yards (about 73 metres) of the *Cotopa* thread, drying this miniature hank in an oven and removing same in a closed weighing

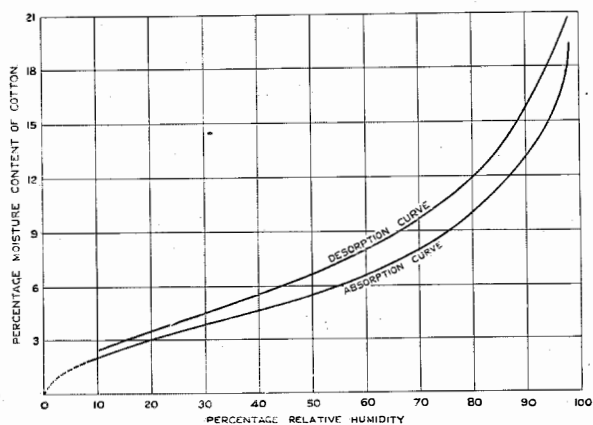

Figure 19—Absorption and Desorption of Water at 20°C. by Soda-Boiled Cotton.

bottle, cooling, weighing, and subtracting weight of bottle. A few inches are examined to determine the number of ends and whether single or double ply. The weight of the miniature hank is increased by 3%, this being the agreed average moisture content, and the count obtained from this augmented weight by a simple calculation. The results of at least five tests from five cheeses taken at random should be within $\pm 7\%$ of the required value.

THE MEASUREMENT OF THE BREAKING STRENGTH OF COTOPA AND ITS ELONGATION AT BREAK

These are based on the methods of the Manchester Chamber of Commerce, using a Baer tensile strength and elongation tester.

The test samples are conditioned for 24 hours at 70% relative humidity.

The machine consists essentially of a light arm pivoted near the upper end, to which is attached one end of the sample; the other end of the sample is attached to a clamp connected to a heavy plunger working in an oil filled dashpot. On release the plunger pulls the sample down, thus causing the lower end of the arm to move over a graduated scale as the tension increases. A catch automatically locks the arm when the sample breaks and both tensile strength and elongation can be read off directly from the respective scales.

The mechanical conditions under which the test is made are as follows:

Length of test specimen	18 inches (46 cm.)
Speed of traverse	1 inch in 5 seconds (5 cm. in 10 seconds)
Tensioning weight	100 grains (6.6 grams approx.)

When examined in the above manner, *Cotopa* has been found to have figures of the order indicated in Table I and these can be taken as a useful working basis:

TABLE I

Nominal		Approximate Equivalent in International Metric Count	Breaking Strength in Oz.	Elongation at Break %
English Cotton Count	Yards per Pound		Mean of at Least 10 Tests	Mean of at Least 10 Tests
1/10's	8,400	1/17's	20.0 (570 grams)	7.5
1/20's	16,800	1/34's	11.0 (310 ")	6.8
1/30's	25,200	1/51's	7.7 (220 ")	6.4
1/40's	33,600	1/68's	5.9 (170 ")	6.1
1/50's	42,000	1/85's	4.7 (133 ")	5.9
1/60's	50,400	1/102's	4.0 (113 ")	5.8
1/70's	58,800	1/119's	3.4 (97 ")	5.6
1/80's	67,200	1/135's	3.0 (85 ")	5.5
1/90's	75,600	1/152's	2.7 (77 ")	5.4
1/100's	84,000	1/169's	2.4 (68 ")	5.3
2/10's	4,032	2/17's	50.0 (1420 ")	8.5
2/20's	8,064	2/34's	24.0 (680 ")	7.8
2/30's	12,096	2/51's	17.0 (480 ")	7.4
2/40's	16,128	2/68's	13.0 (370 ")	7.2
2/50's	20,160	2/85's	10.6 (300 ")	6.9
2/60's	24,192	2/102's	8.8 (250 ")	6.8
2/70's	28,224	2/119's	7.6 (215 ")	6.6
2/80's	32,256	2/135's	6.6 (187 ")	6.5
2/90's	36,288	2/152's	5.9 (167 ")	6.4
2/100's	40,320	2/169's	5.4 (153 ")	6.3

In the event of *Cotopa* yarns of count other than those enumerated in Table I being required, proportionate figures obtained by graphical interpolation are to be employed.

The two-ply yardage figures allow for a 4% take-up.

LOSS OF STRENGTH ON HEATING

Test is conducted by comparing the tensile strengths of the yarn before and after being heated in an oven for 24 hours at 250° Fahrenheit and reconditioned at 70% relative humidity. The breaking strength and elongation at break should be at least 90% of the values shown in Table I.

CONDITIONING OF FIBROUS MATERIALS PRIOR TO BREAKING STRENGTH AND ELONGATION TESTS

The sample to be subsequently tested should be placed for at least 24 hours previous to test in a laboratory desiccator in which the lower portion is filled with a sulphuric acid solution of a suitable specific gravity to give the required relative humidity determined from the data published by R. E. Wilson,²⁴ taking adequate

precautions against contamination of the sample with the sulphuric acid solution employed. The tests to be subsequently made should be carried out immediately on removal from the conditioning vessel which should be kept in a position where it is exposed to the minimum change of temperature possible under the conditions.

THE MEASUREMENT OF THE ACIDITY OR ALKALINITY OF A STANDARD AQUEOUS EXTRACT OF FIBROUS INSULATING MATERIALS

Standard Water Extract. In both this and the following section, a standard water extract is prepared using 5 grams of textile and 100 millilitres of distilled water of pH between 6 and 7 and specific conductivity less than 5 micromhos. The textile and water are then shaken in a stoppered glass bottle of 500 millilitres capacity for 1 hour at approximately 100 reciprocations of the shaker per minute.

pH of Water Extract Test. For many years some form of litmus paper test has been used to determine the degree of acidity or alkalinity of textile, paper, and similar insulating materials but, owing to the difficulty inherent in verbal description of small colour changes, an investiga-

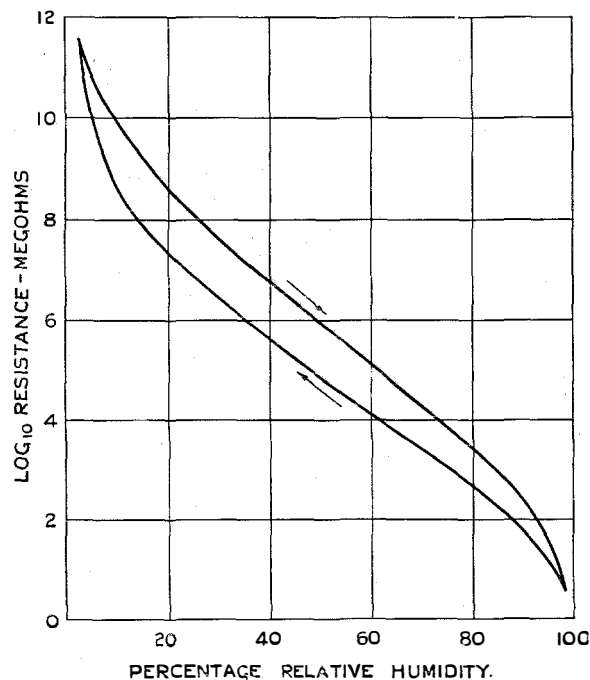

Figure 20—Insulation Resistance—Relative Humidity Curve for Cotton Threads Showing the Dependence of Insulation Resistance on the Direction from which Equilibrium is Approached.

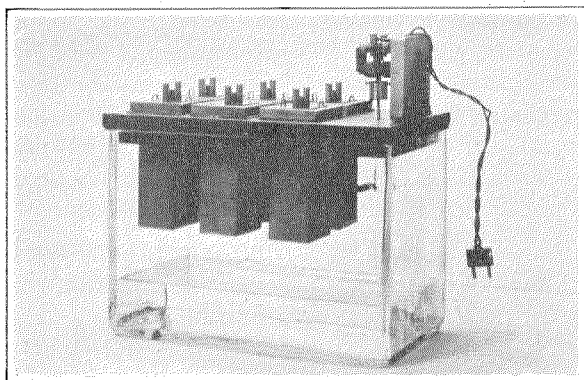

Figure 21—Vessel for Conditioning Samples at Desired Humidity.

tion into this problem was carried out in 1931 at the Chemical and Physical Laboratory, Standard Telephones and Cables, during which all the available methods were compared and it was decided to standardise on the method of determining the pH value of a standard water extract of the textile, prepared as above, by means of a Hellige comparator in which the colour of a 1 cm. thickness of solution and indicator is compared with the colours of a series of glass slides set in a revolving bakelite disc. When a colour match is obtained the corresponding pH is read off from the instrument. This method has the advantages that it is one of the simplest of the many alternatives, that it is quick, and that the colour standards being of glass, do not alter with passage of time. The degree of accuracy, which is about ± 0.1 pH is amply sufficient for the examination of textiles, papers, and other similar purposes. A full account of the alternatives available and a criticism of the same was published²⁵ in 1932 from the Chemical and Physical Laboratory, Standard Telephones and Cables, London, *Cotopa* samples have invariably been found to have pH values between 5.5 and 8.5.

THE MEASUREMENT OF THE SPECIFIC ELECTRICAL CONDUCTIVITY OF A STANDARD AQUEOUS EXTRACT OF FIBROUS INSULATING MATERIALS

As the presence of neutral salts, which could have deleterious effects both in the form of lowered insulation resistance and electrolytic corrosion in service, would not be detected by the above, the specific conductivity of the above standard water extract is also measured. This is

done by drawing a portion of the water extract up into a special conductivity cell, and measuring the resistance with an Evershed and Vignoles "Megger" (checked against National Physical Laboratory Standards) between two electrodes sealed into the cell, after the temperature has been raised to 25° C by an electric heater. The specific conductivity of the extract in micromhos is then obtained by dividing the constant of the cell by the reading in megohms. The constant of the cell is obtained by standardising with an accurately prepared solution of N/100 potassium chloride on which very accurate determinations are available (see International Critical Tables). All the values ordinarily met in this kind of work can be determined with a two-range "Megger," having ranges 2-1,000 megohms and .02-10 megohms, used in conjunction with a conductivity cell having a constant of 4,000-8,000. The accuracy of measurement (about $\pm 3\%$) has been found to be within the degree of variation of the best textile yarns. A short reference²⁵ to the method was published in 1932 from the Chemical and Physical Laboratory, Standard Telephones and Cables in the "Textile Manufacturer," and a full description and criticism of the method will be published shortly in the same journal.

Extracts from *Cotopa* yarn nearly always give figures below 100 micromhos. Extracts from ordinary grey cotton give figures ranging from 600-1,000 micromhos.

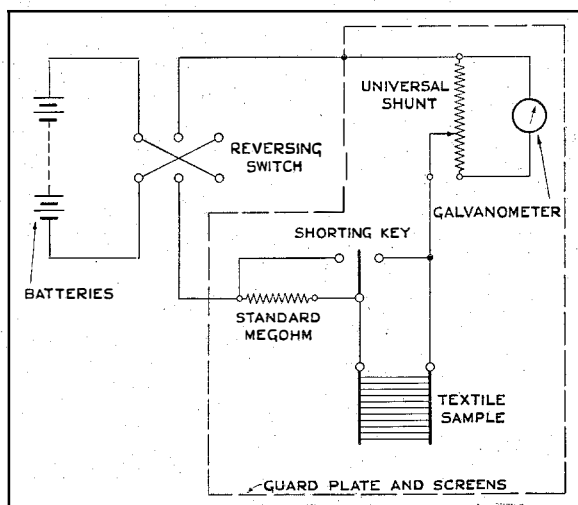

Figure 22—Schematic Diagram of D-C. Insulation Resistance Test Set for Textile Samples.

THE DETECTION OF FREE DYE PRESENT IN TEXTILES REMOVABLE BY MECHANICAL MEANS

The method used for this purpose is the simple but effective one of rubbing a 5 gram hank backwards and forwards on a piece of white paper ten times under moderate pressure. The dye in coloured *Cotopas* is quite fast to the most stringent of rubbing tests.

THE DETECTION OF DYESTUFFS IN TEXTILES REMOVABLE BY SOLVENTS

In the case of hot tests, a 1 gram hank of the dyed textile is heated for 10 minutes in a beaker or flask with 100 millilitres of the liquid at 125° C or at the boiling point of the liquid if this is lower than 125° C. In the case of cold tests, a 1 gram hank is shaken for 10 minutes with 100 millilitres of the liquid at ordinary temperatures.

Using boiling water, not more than a trace of dye has been found to be extracted from any of the coloured *Cotopas*. They are also tested with hot beeswax, paraffin wax, petroleum jelly, and cold acetone without more than a trace of the dye being extracted.

COLOUR SHADES

The colour shades of *Cotopa* yarns are tested by comparison with standard cheeses which have been previously selected as matching exactly under standard conditions the samples on the standard shade cards. The colour shades of dyed *Cotopas* are generally faster to light than those of the corresponding coloured soft cottons in general use in the electrical industry.

TENDERING DUE TO DYESTUFFS

In order to obviate completely the possibility of *Cotopa* developing acidity in storage and tendering on heating, as often happens with cottons dyed with sulphide black dyes, no sulphide dyes at all are used in *Cotopa* for electrical purposes.

Acknowledgements

The author wishes to express his thanks to Dr. A. Rheiner of Chemische Fabrik vormals Sandoz for the microphotographs of cross-sections of esterified cotton fibres shown in Figs. 14, 15, 16, and, 17, which were reproduced in the Journal of the Society of Dyers and Colourists for May, 1934, and to Professor F. M. Rowe and the Society of Dyers and Colourists for the loan of the blocks of same; also

to Mr. W. T. Astbury and the Oxford University Press for permission to copy the atomic diagrams shown in Figs. 10 and 12 from Mr. Astbury's book, "Fundamentals of Fibre Structure."

Bibliography

1. Rheiner, "Die niedrig acetylierten Faserzellulosen." Lecture delivered at the Ecole Supérieure de Chimie, Mulhouse; also in "Argewandte Chemie" 46, 675 (1933).
2. British Patent 306,877.
3. British Patent 324,680.
4. Denham, Journal of the Textile Institute 14 T85-113 (1923).
5. Balls, Proceedings of the Royal Society B90 542 (1919).
6. Harrison, Journal of the Society of Dyers and Colourists 31 198 (1915); also Transactions of the National Association of Cotton Manufacturers 101 201 (1916).
7. Nakano, Journal of the Cellulose Institute (Tokio) 5, 238, (1929).
8. Ludke, Melliand Textilberichte 10, 445-448 (1929). Sisido, Journal of the Cellulose Institute (Tokio 6, 148 (1930).
9. Haworth, "The Constitution of Cellulose". Jubilee number of the Society of Dyers and Colourists (1934).
10. Mark, Journal of the Society of Dyers and Colourists, pp. 53-59 (1932).
11. Astbury, "Fundamentals of Fibre Structure" (1933).
12. Staudinger, Transactions of the Faraday Society, pp. 18-32 (Jan. 1933).
13. Evershed, Journal of the Institute of Electrical Engineers 52, p. 51.
14. Murphy and Walker, Journal of Physical Chemistry 32, pp. 1761-1786 (1928).
15. Williams and Murphy, Transactions of the American Institute of Electrical Engineers 48, pp. 568-575 (1929).
16. Murphy, Journal of Physical Chemistry 33, pp.509-532 (1929).
17. Sutherland, Philosophical Magazine 50, 460 (1900).
18. Armstrong, Proceedings of the Royal Society 81, 80 (1908).
19. Marsh and Earp, Transactions of the Faraday Society, pp. 173-193 (Jan. 1933).
20. O'Sullivan, In the discussion of the last paper.
21. Hess, Annalen der Chemie, 435, 65 (1923); also given in full in "The Methods of Cellulose Chemistry" by Doree (1933).
22. Glen and Wood, Transactions of the American Institute of Electrical Engineers, pp. 576-581 (1929).
23. Urquhart and Williams, Journal of the Textile Institute, pp. T137-148 (1924).
24. Wilson, Industrial and Engineering Chemistry 13 326 (1921).
25. New, "Textile Manufacturer," Feb. 1932, pp. 67-69; also "American Dyestuff Reporter," 1932, pp. 180-2 and 201-3.

Recent Telecommunication Developments of Interest

A SIMPLE and reliable means of providing a permanent record of a cathode ray oscillograph wave form has been met by the 74300-A Film Camera developed by Standard Telephones and Cables, Limited, London. The camera and auxiliary equipment have been specially designed so that operation, comprising loading, exposing, and developing the film can be carried out in daylight, without the necessity of a dark room, and in any location where only running tap water is available. Care has been taken to make the operation of the camera a simple and straightforward process that can be understood by any operator who need not necessarily have had previous experience with photographic work. The arrangements for loading the camera with films are also very simple, and a minimum of controls are provided to effect the exposure.

The accompanying illustration shows the tube unit and camera arranged to photograph the image on the screen of the oscillograph tube, a distance piece being provided to maintain the correct focus and to exclude light. The tube unit can either be used horizontally for photographic work as shown, or vertically, in which case the back of the screen is seen through the side wall of the tube, a suitable aperture being provided in the front of the box.

The necessary voltages for the anode and filament are obtained from a separate mains unit which also provides the supplies for the linear time base. The latter provides means of synchronising wave forms over a frequency range from a few cycles per second up to approximately 50 kc. The camera uses 35 mm. cinema film in 100 foot spools arranged for daylight loading. The film after passing through the exposure gate is fed into interchangeable film receivers which enable individual exposed lengths to be cut off and developed separately.

The drive consists of a powerful clockwork motor which enables film speeds from about 1 inch up to 20 inches per second to be obtained. Provision is made for an external motor drive if required. The film can either be fed continuously or intermittently frame by frame and the

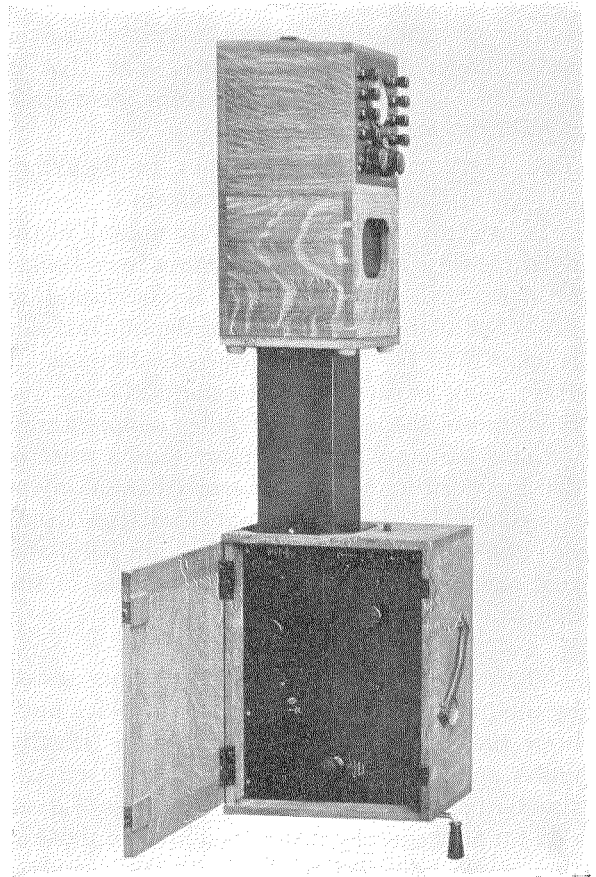

shutter lever is fitted with contacts to open or close the circuits under test.

Additional units comprise a dual wave unit to enable two waves to be seen on the screen simultaneously, a unit to enable oscillator calibration to be made conveniently and quickly, resistance potentiometers for mains voltages, and a wide range of reflecting coils.

• • •

THE self-contained portable cathode ray oscillograph unit shown in the accompanying illustration is a recent development of Standard Telephones and Cables, Limited, London. It is a complete cathode ray oscillograph equipment, the only source of power being a 2 volt accumulator of the unspillable type, contained within the case. The accumulator provides current for the tube and operates a small

induction coil which steps up the voltage and, by means of a metal rectifier and smoothing circuit, provides the necessary H.T. for the anode supply to the tube. A single traverse time

6 inches by 6 inches by 15 inches high, weighs approximately 12 lbs., and has been designed to meet the demand for a cathode ray oscillograph equipment which is completely self-contained and portable and which is independent of power main supplies.

• • •

THE No. 7301 type Mercury Interrupter Relay recently developed by the Bell Telephone Manufacturing Company, Antwerp, is primarily for use in remote controlled street signalling and power systems, also in radio transmitters.

It meets the demand for mercury interrupters having a capacity of from 2 to 10 amperes operated by low voltage d-c. and can be adapted to carry 1, 2, 3, or 4 mercury tubes as required,

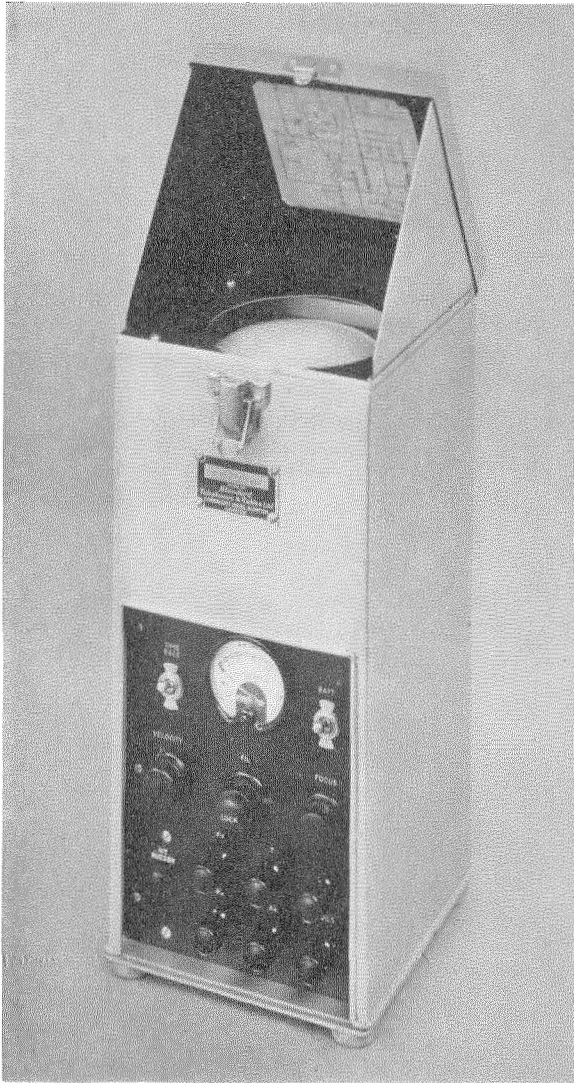

base unit is incorporated, giving twelve different speeds with a range from about 10 cm. up to 50 m. per second; and a pair of deflecting coils is fitted on the tube. The induction coil is shielded magnetically and the accumulator, which has a capacity of 20 A.H., provides sufficient current for 10 hours of operation. The top of the case is provided with a carrying handle and is hinged and fitted with side flaps which exclude light and reflections from the screen.

The unit is simple and robust and measures

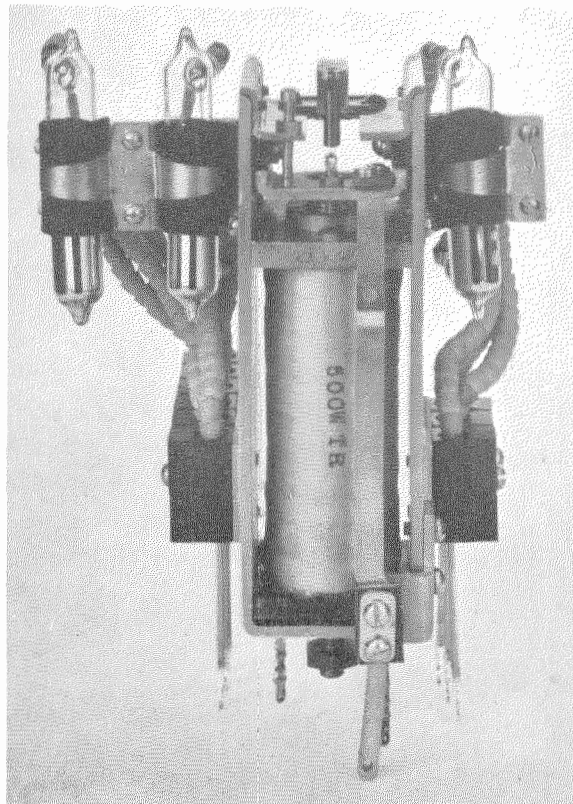

each tube furnishing single make, single break or change-over contacts. Special types having capacities up to 50 amperes can be supplied if required.

When desired, an additional contact assembly,

operated by a fibre tongue forming part of the armature, can be provided on top of the coil frame to control auxiliary circuits.

The dimensions of the relay are as follows:

Length in front of mounting plate	105 mm.
Width—Without tubes (Add approximately 20 mm. per mercury tube)	33 mm.
Height—(Add 15 mm. for additional contact assembly)	30 mm.

The illustration shows a form of mercury relay arranged for soldered connections. Types are provided having screw and nut connections for use on power boards, also a locking feature released by the operation of an additional clutch.

• • •

THE Compañía Telefonica Nacional de España, for the year 1934 reports a net increase of 22,537 stations, representing approxi-

mately twice the station gain for 1933. The total number of stations at the end of 1934 was 303,766. This figure compares with a total of 90,000 in 1924, the year in which the company was organized to assist technically and financially in the development of the Spanish telephone system.

Especially interesting is the considerable development of teletype printer service in Spain during 1934. The number of news agencies using this service increased from one to four during the year, and transmission is now given to 15 provincial cities. One agency is equipped for simultaneous transmission to 14 different cities.

During the year a police hook-up involving three cities was provided and it is anticipated that this form of communication will be developed extensively during the coming year.

Licensee Companies

BELL TELEPHONE MANUFACTURING COMPANY.....	<i>Antwerp, Belgium</i>
<i>Branches: Brussels.</i>	
BELL TELEPHONE MANUFACTURING COMPANY.....	<i>Berne, Switzerland</i>
BELL TELEPHONE MANUFACTURING COMPANY.....	<i>The Hague, Holland</i>
CHINA ELECTRIC COMPANY, LIMITED.....	<i>Shanghai, China</i>
<i>Branches: Canton, Hankow, Hongkong, Peiping, Tientsin.</i>	
COMPAÑÍA STANDARD ELECTRIC ARGENTINA.....	<i>Buenos Aires, Argentina</i>
INTERNATIONAL STANDARD ELECTRIC CORPORATION, <i>Branch Office,</i>	
	<i>Rio de Janeiro, Brazil</i>
LE MATÉRIEL TÉLÉPHONIQUE.....	<i>Paris, France</i>
<i>Branch: Rabat, Morocco.</i>	
NIPPON DENKI KABUSHIKI KAISHA.....	<i>Tokyo, Japan</i>
<i>Branches: Osaka, Dairen, Taihoku.</i>	
FERDINAND SCHUCHHARDT, BERLINER FERNSPRECH-UND TELEGRAPHENWERK AKTIENGESELLSCHAFT.....	<i>Berlin, Germany</i>
STANDARD ELECTRIC AKTIESELSKAB.....	<i>Copenhagen, Denmark</i>
STANDARD TELEFON—OG KABELFABRIK A/S.....	<i>Oslo, Norway</i>
STANDARD ELECTRIC COMPANY W POLSCE SP. Z. O. O.....	<i>Warsaw, Poland</i>
STANDARD ELECTRIC DOMS A SPOL.....	<i>Prague, Czechoslovakia</i>
<i>Branch: Bratislava.</i>	
STANDARD ELECTRICA ROMANA S/A.....	<i>Bucharest, Rumania</i>
STANDARD ELÉCTRICA, S. A.....	<i>Madrid, Spain</i>
<i>Branches: Barcelona, Santander.</i>	
STANDARD ELECTRICA, S. A.....	<i>Lisbon, Portugal</i>
STANDARD ELETRICA ITALIANA.....	<i>Milan, Italy</i>
<i>Branch: Rome.</i>	
STANDARD TELEPHONES AND CABLES, LIMITED.....	<i>London, England</i>
<i>Branches: Birmingham, Glasgow, Leeds, Manchester, Dublin, Cairo, Johannes- burg, Calcutta.</i>	
STANDARD TELEPHONES AND CABLES (AUSTRALASIA), LIMITED.....	<i>Sydney, Australia</i>
<i>Branches: Melbourne; Wellington, New Zealand.</i>	
STANDARD VILAMOSÁGI RÉSZVÉNY TÁRSASÁG.....	<i>Budapest, Hungary</i>
SUMITOMO ELECTRIC WIRE & CABLE WORKS, LIMITED.....	<i>Osaka, Japan</i>
VEREINIGTE TELEPHON-UND TELEGRAPHENFABRIKS AKTIEN-GESELLSCHAFT, CZEIJA, NISSL & CO.....	<i>Vienna, Austria</i>

Sales Offices and Agencies Throughout the World
